

***ARMY TM 10-4520-259-13&P AIR FORCE T.O. 35E7-4-27-1**

**OPERATOR'S, UNIT AND DIRECT SUPPORT MAINTENANCE MANUAL
(INCLUDING REPAIR PARTS AND SPECIAL TOOLS LIST)**

HEATER, WATER, LIQUID FUEL M-80, NSN: 4520-01-162-0385 M-85, NSN: 4520-01-237-3719

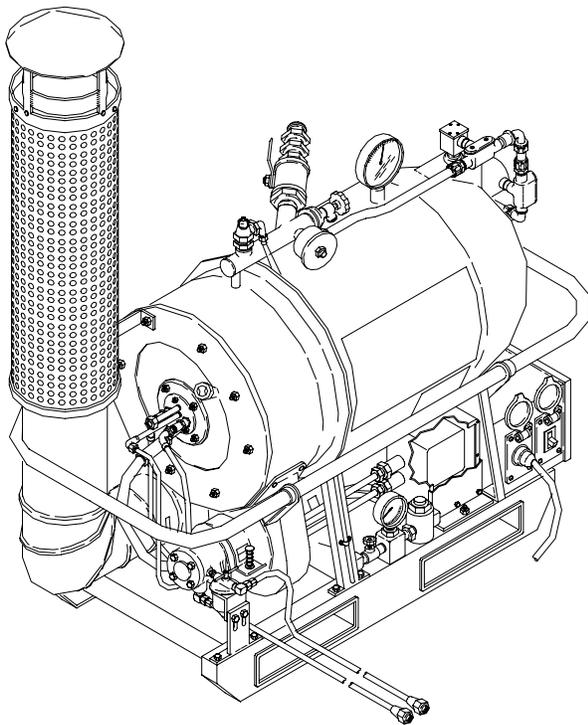

M-80

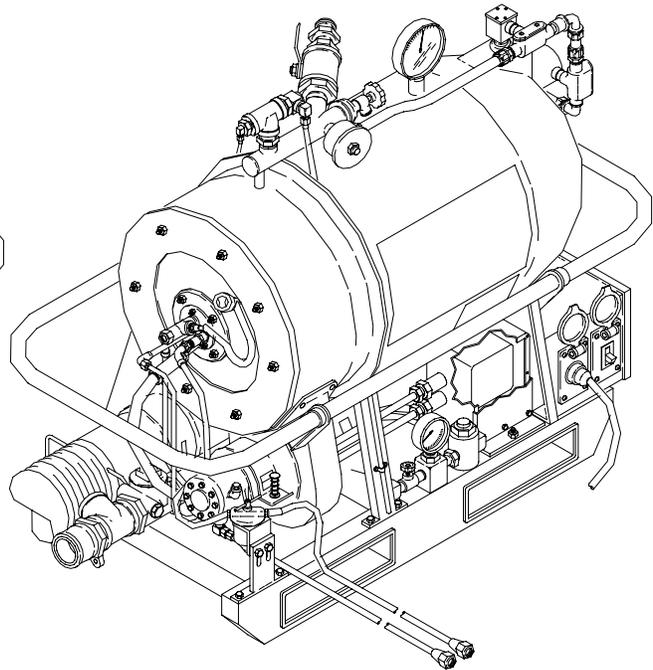

M-85

DISTRIBUTION STATEMENT A. – Approved for public release; distribution is unlimited.

*This manual supercedes TM 10-4520-259-13&P, dated 31 August 1993, including all changes.

HEADQUARTERS, DEPARTMENT OF THE ARMY

CHANGE 2 – 31 MARCH 2006

30 June 2005

WARNING SUMMARY

This warning summary contains general safety warnings and hazardous materials warnings that must be understood and applied during operation of this equipment. Failure to observe these precautions could result in serious injury or death to personnel. Also included are explanations of safety and hazardous materials icons used within the technical manual.

EXPLANATION OF SAFETY WARNING ICONS



ELECTRICAL - electrical wire to arm with electricity symbol running through human body shows that shock hazard is present.



SHARP OBJECT - pointed object in hand shows that a sharp object presents a danger to limb.



HEAVY OBJECT - human figure stooping over heavy object shows physical injury potential from improper lifting technique.



EXPLOSION - rapidly expanding symbol shows that the material may explode if subjected to high temperatures, sources of ignition or high pressure.



FIRE - flame shows that a material may ignite and cause burns.



VAPOR - human figure in a cloud shows that material vapors present a danger to life or health.



HOT AREA - hand over object radiating heat shows that part is hot and can burn.



ELECTRICAL - electrical wire to hand with electricity symbol running through hand shows that shock hazard is present.

GENERAL SAFETY WARNINGS DESCRIPTION

WARNING



The water heater is heavy. Applicable warnings and instructions are contained in the set-up, and maintenance procedures, calling for the required number of persons needed to lift the heater components. To prevent injuries ensure that the required number of people is on hand for the lift. Be sure to lift with legs, not back, to prevent injury.

WARNING



During some maintenance procedures electrical wires must be cut and some metal parts of the water heater may have sharp edges. Be careful when handling and assembling water heater components to prevent injuries from cuts.

WARNING



The water heater operates at High Voltages. Use extreme caution. Touching a live wire can cause serious injury or death. Follow warnings contained in the operational and maintenance procedures to prevent serious injuries to personnel.

WARNING



Exposed fuel and fuel vapor can ignite or explode, resulting in possible injury or death. Observe proper safety precautions when servicing the heater fuel system. Ensure that the heater has cooled down before servicing the burner.

WARNING



Fuel is very flammable and can ignite easily. To avoid serious injury or death, keep fuel away from open flame. Do not work on fuel system when heater is hot. Shut off heater and do not smoke when working on fuel system.

WARNING



Drycleaning solvent, P-D-680 is potentially dangerous. Avoid repeated or prolonged breathing of vapors and skin contact with liquid. Do not use near open flame, arcing equipment, or other ignition sources. Use in well ventilated places.

WARNING



Lethal voltage is present when the water heater is connected to a power source. Disconnect from power source before inspecting or repairing any electrical component. Be careful not to touch electrical connections. Electrical shock and /or death may result from failure to heed this warning.

WARNING



Some burner parts are hot during operation. Let the water heater cool down before performing any service or maintenance to prevent injuries from burns.

CHANGE
NO. 2

HEADQUARTERS,
DEPARTMENT OF THE ARMY
WASHINGTON, D.C., 31 MARCH 2006

OPERATOR'S, UNIT AND DIRECT SUPPORT MAINTENANCE MANUAL
(INCLUDING REPAIR PARTS AND SPECIAL TOOLS LIST)

HEATER, WATER, LIQUID FUEL

M-80, NSN: 4520-01-162-0385

M-85, NSN: 4520-01-237-3719

DISTRIBUTION STATEMENT A: - Approved for public release; distribution is unlimited.

TM 10-4520-259-13&P, dated 30 June 2005, is changed as follows:

1. File this sheet in the front of the manual for reference.
2. This change adds Air Force T.O. 35E7-4-27-1 to include the Air Force as a joint user of the M-80/M-85 Water Heater.
3. This change updates several publication references.
4. New or updated text is indicated by a vertical bar in the outer margin.
5. Added illustrations are indicated by a vertical bar adjacent to the figure number. Changed illustrations are indicated by a miniature hand adjacent to the updated area and a vertical bar adjacent to the figure number.
6. Remove old pages and insert new pages as indicated below.

Remove Pages

Front Cover
A/(B Blank)
i – iii/(iv Blank)

Insert Pages

Front Cover
A/(B Blank)
i – iii/(iv Blank)
2028 Front/Back

7. Replace the following work packages with their revised version.

Work Package Number

WP 0001 00
WP 0008 00
WP 0011 00
WP 0036 00

C2

By Order of the Secretary of the Army:

PETER J. SCHOOMAKER
General, United States Army
Chief of Staff

Official:

JOYCE E. MORROW
Administrative Assistant to the
Secretary of the Army
0607510

JOHN P. JUMPER
GENERAL, USAF
Chief of Staff

GREGORY S. MARTIN
General, USAF
Commander, AFMC

DISTRIBUTION: To be distributed in accordance with initial distribution number (IDN) 256159 requirements for TM 10-4520-259-13&P.

CHANGE
NO. 1

HEADQUARTERS,
DEPARTMENT OF THE ARMY
WASHINGTON, D.C., 31 AUGUST 2005

OPERATOR'S, UNIT AND DIRECT SUPPORT
MAINTENANCE MANUAL
(INCLUDING REPAIR PARTS AND SPECIAL TOOLS LIST)
HEATER, WATER, LIQUID FUEL
M-80, NSN: 4520-01-162-0385
M-85, NSN: 4520-01-237-3719

DISTRIBUTION STATEMENT A: - Approved for public release; distribution is unlimited.

TM 10-4520-259-13&P, dated 30 June 2005, is changed as follows:

1. File this sheet in the front of the manual for reference.
2. This change implements the Army Maintenance Transformation and changes the Maintenance Allocation Chart (MAC) to Support Field and Sustainment Maintenance.
3. New or updated text is indicated by a vertical bar in the outer margin.
4. Added illustrations are indicated by a vertical bar adjacent to the figure number. Changed illustrations are indicated by a miniature hand adjacent to the updated area and a vertical bar adjacent to the figure number.
5. Remove old pages and insert new pages as indicated below.

Remove Pages
A/(B Blank)

Insert Pages
A/(B Blank)
DA 2028

6. Replace the following work packages with their revised version.

Work Package Number

WP 0037 00
WP 0038 00

By Order of the Secretary of the Army
C1

PETER J. SCHOOMAKER
General, United States Army
Chief of Staff

Official:



SANDRA R. RILEY
Administrative Assistant to the
Secretary of the Army
0521628

Distribution:

To be distributed in accordance with initial distribution number (IDN) 256159 requirements for TM 10-4520-259-13&P.

INSERT LATEST CHANGED PAGES/WORK PACKAGES. DESTROY SUPERSEDED DATA.

LIST OF EFFECTIVE PAGES/WORK PACKAGES

NOTE: The portion of the text affected by the update is indicated by a vertical line in the outer margins of the page. Updates to illustrations are indicated by miniature pointing hands or vertical lines in the outer margins of the page in the area of the illustration changed. Zero in the "Change No." column indicates an original page or work package.

Dates of issue for the original manual and changed pages/work packages are:

Original 30 June 2005
 Change 1 31 August 2005
 Change 2 31 March 2006

TOTAL NUMBER OF PAGES FOR FRONT AND REAR MATTER IS 24. THE TOTAL NUMBER OF WORK PACKAGES IS 58 CONSISTING OF THE FOLLOWING:

Page/WP No.	Change No.	Page/WP No.	Change No.	Page/WP No.	Change No.
Front Cover	2	WP 0017 00 (8 pgs)	0	WP 0038 00 (2 pgs)	1
Warning	0	Chp 6 title page	0	WP 0039 00 (8 pgs)	0
i – iii/(iv Blank)	2	WP 0018 00 (4 pgs)	0	WP 0040 00 (4 pgs)	0
v/(vi Blank)	0	WP 0019 00 (8 pgs)	0	WP 0041 00 (4 pgs)	0
WP 0001 00 (4 pgs)	2	WP 0020 00 (4 pgs)	0	WP 0042 00 (4 pgs)	0
Chp 1 title page	0	WP 0021 00 (6 pgs)	0	WP 0043 00 (4 pgs)	0
WP 0002 00 (8 pgs)	0	WP 0022 00 (8 pgs)	0	WP 0044 00 (4 pgs)	0
WP 0003 00 (4 pgs)	0	WP 0023 00 (2 pgs)	0	WP 0045 00 (4 pgs)	0
Chp 2 title page	0	WP 0024 00 (2 pgs)	0	WP 0046 00 (4 pgs)	0
WP 0004 00 (10 pgs)	0	WP 0025 00 (4 pgs)	0	WP 0047 00 (8 pgs)	0
WP 0005 00 (12 pgs)	0	WP 0026 00 (4 pgs)	0	WP 0048 00 (4 pgs)	0
WP 0006 00 (2 pgs)	0	WP 0027 00 (22 pgs)	0	WP 0049 00 (6 pgs)	0
Chp 3 title page	0	Chp 7 title page	0	WP 0050 00 (4 pgs)	0
WP 0007 00 (4 pgs)	0	WP 0028 00 (4 pgs)	0	WP 0051 00 (4 pgs)	0
Chp 4 title page	0	Chp 8 title page	0	WP 0052 00 (4 pgs)	0
WP 0008 00 (2 pgs)	2	WP 0029 00 (12 pgs)	0	WP 0053 00 (2 pgs)	0
WP 0009 00 (2 pgs)	0	WP 0030 00 (6 pgs)	0	WP 0054 00 (4 pgs)	0
WP 0010 00 (2 pgs)	0	WP 0031 00 (6 pgs)	0	WP 0055 00 (4 pgs)	0
WP 0011 00 (16 pgs)	2	WP 0032 00 (10 pgs)	0	WP 0056 00 (2 pgs)	0
WP 0012 00 (2 pgs)	0	WP 0033 00 (4 pgs)	0	WP 0057 00 (2 pgs)	0
WP 0013 00 (2 pgs)	0	WP 0034 00 (6 pgs)	0	WP 0058 00 (2 pgs)	0
WP 0014 00 (2 pgs)	0	WP 0035 00 (8 pgs)	0	Index-1 – Index-6	0
WP 0015 00 (2 pgs)	0	Chp 9 title page	0	Back Cover	0
WP 0016 00 (2 pgs)	0	WP 0036 00 (2 pgs)	2		
Chp 5 title page	0	WP 0037 00 (4 pgs)	1		

TECHNICAL MANUAL
OPERATOR'S, UNIT AND
DIRECT SUPPORT MAINTENANCE MANUAL
(INCLUDING REPAIR PARTS AND SPECIAL TOOLS LIST)

HEATER, WATER, LIQUID FUEL
M-80, NSN: 4520-01-162-0385
M-85, NSN: 4520-01-237-3719

REPORTING ERRORS AND RECOMMENDING IMPROVEMENTS

You can help improve this manual. If you find any mistakes or if you know of a way to improve the procedures, please let us know. Service, should be submitted as follows:

(A) Army - Mail your letter or DA Form 2028 (Recommended Changes to Publications and Blank Forms) located in the back of this manual, directly to: Commander, US Army Tank-automotive & Armament Command, ATTN: AMSTA-LC-CECT, Kansas Street, Natick, MA 01760. You may also send in your recommended changes via electronic mail or by fax. Our fax number is DSN 256-5205 or commercial 508-233-5205. Our e-mail address is amssbriml@natick.army.mil.

(F) Air Force – Reports by U.S. Air Force units should be submitted on AFTO Form 22 (Technical Order Publication Improvement Report and Reply) and forwarded to the address prescribed above for the Army. An information copy of the prepared AFTO Form 22 shall be furnished to WP-ALC/TILTA, 420 2nd Street, Suite 100, Robins AFB, GA 31098-1640.

DISTRIBUTION STATEMENT A. Approved for public release. Distribution is unlimited.

*This manual supercedes TM 10-4520-259-13&P, dated 31 August 1993, including all changes.

TABLE OF CONTENTS

	<u>WP Sequence No.</u>
Warning Summary	
List of Effective Pages	
How To Use This Manual	
General Information.....	0001 00
CHAPTER 1 – DESCRIPTION AND THEORY OF OPERATION	
Equipment Description and Data.....	0002 00
Theory of Operation	0003 00
CHAPTER 2 – OPERATOR INSTRUCTIONS	
Description and Use of Operators Controls and Indicators	0004 00
Operation Under Usual Conditions.....	0005 00
Operation Under Unusual Conditions.....	0006 00
CHAPTER 3 – OPERATOR TROUBLESHOOTING PROCEDURES	
Operator Troubleshooting Index.....	0007 00

TABLE OF CONTENTS - continued

WP Sequence No.

CHAPTER 4 - OPERATOR MAINTENANCE INSTRUCTIONS

Service Upon Receipt.....	0008 00
Preventive Maintenance Checks and Services (PMCS), Introduction	0009 00
Lubrication Requirements	0010 00
Preventive Maintenance Checks and Services (PMCS)	0011 00
Fuel Supply Control Components	0012 00
M-80 Smokestack and Guard Assembly/M-85 Exhaust Duct	0013 00
Ignition Cable Assembly	0014 00
Blower Assembly	0015 00
Water Vessel and Skid Assembly	0016 00

CHAPTER 5 - UNIT MAINTENANCE TROUBLESHOOTING PROCEDURES

Troubleshooting Index.....	0017 00
----------------------------	---------

CHAPTER 6 - UNIT MAINTENANCE INSTRUCTIONS

Fuel Supply Control Components	0018 00
Burner Head Assembly	0019 00
Smokestack and Guard Assembly M-85, Exhaust Duct M-80	0020 00
Ignition Transformer and Ignition Cable Assemblies.....	0021 00
Fuel Filter Assembly.....	0022 00
Fuel Pump Assembly	0023 00
Water Vessel and Skid Assembly	0024 00
Upper and Lower Manifold Assembly.....	0025 00
Drum Fill Adapter Assembly, Type II.....	0026 00
UV and IR Scanner and Flame Control Safeguard Assembly.....	0027 00

CHAPTER 7 – DIRECT SUPPORT TROUBLESHOOTING PROCEDURES

Direct Support Troubleshooting Index.....	0028 00
---	---------

CHAPTER 8 – DIRECT SUPPORT MAINTENANCE INSTRUCTIONS

Electrical Components	0029 00
Blower Assembly.....	0030 00
Blower and Fuel Pump Motor.....	0031 00
Fuel Pump Assembly	0032 00
Air Shutter Assembly.....	0033 00
Water Vessel and Skid Assembly I.....	0034 00
Control Box Assembly	0035 00

CHAPTER 9 – SUPPORTING INFORMATION

References.....	0036 00
Maintenance Allocation Chart (MAC), Introduction	0037 00
Maintenance Allocation Chart (MAC).....	0038 00
Repair Parts and Special Tools List (RPSTL), Introduction	0039 00
Group 01 – Fuel Supply Control Components	0040 00
Group 02 – Burner Head Assembly	0041 00
Group 03 – Smokestack and Guard Assembly	0042 00
Group 04 – Ignition Transformer and Cable Assemblies	0043 00
Group 0401 – Electrical Components	0044 00
Group 05 – Blower Assembly.....	0045 00

TABLE OF CONTENTS - continued

	<u>WP Sequence No.</u>
CHAPTER 9 – SUPPORTING INFORMATION - continued	
Group 0502 – Fuel Filter Assembly	0046 00
Group 0503 – Fuel Pump	0047 00
Group 06 – Water Vessel and Skid Assembly	0048 00
Group 0601 – Upper and Lower Manifold Assembly.....	0049 00
Group 07 – Control Box Assembly	0050 00
Group 0701 – UV and IR Flame Safeguard Control.....	0051 00
Group 08 – Drum Fill Adapter Assembly	0052 00
National Stock Number (NSN) Index.....	0053 00
Part Number Index	0054 00
Components of End Item (COEI) and Basic Issue Items (BII) Lists	0055 00
Additional Authorization List (AAL).....	0056 00
Expendable and Durable Items List	0057 00
Mandatory Replacement Parts List	0058 00
ALPHABETICAL INDEX	INDEX-1

HOW TO USE THIS MANUAL

This manual contains General Information, Description and Theory of Operation, Operating Instructions, Operator Preventive Maintenance Checks and Services (PMCS), Troubleshooting, and Maintenance/Repair instructions for the M-80 and M-85 Water Heaters.

Chapter 1 contains introductory information on the M-80/M-85 and its associated equipment as well as Theory of Operation. Chapter 2 includes operating instructions under usual and unusual conditions. Chapter 3 contents include operator troubleshooting procedures. Chapter 4 contains operator PMCS and service procedures. Chapter 5 contains unit troubleshooting procedures. Chapter 6 contains unit maintenance instructions. Chapter 7 contains Direct Support troubleshooting procedures. Chapter 8 contains Direct Support Maintenance instructions. Chapter 9 contains references and other supporting information. Chapter 9 also includes the Repair Parts and Special Tools List (RPSTL) that identifies those parts or tools, which are unique to the operation and maintenance of this equipment.

Manual Organization and Page Numbering System. The manual is divided into nine major chapters that detail the topics mentioned above. Within each chapter are work packages covering a wide range of topics. Each work package is numbered sequentially starting at page 1. The work package has its own page numbering scheme and is independent of the page numbering used by other work packages. Each page of a work package has a page number of the form XXXX YY-ZZ where XXXX is the work package number (e.g. 0010 is work package 10) and YY is the revision number for that work package and ZZ represents the number of the page within that work package. A page number such as 0010 00-1/2 blank means that page 1 contains information, but page 2 of that work package has been intentionally left blank.

Finding Information. The manual has a master Table of Contents as well as separate chapter Tables of Content. The master Table of Contents on page ii and iii permits the reader to find information in the manual quickly. The reader should start here first when looking for a specific topic. The master Table of Contents lists the topics contained within a chapter and where it can be found. Refer to the table of contents at the beginning of each chapter for a detailed listing of each topic and its work package sequence number.

Figures. Figures in this manual are not numbered, they are located immediately following the paragraph which contains their callouts.

An Alphabetical Index can be found at the back of the manual, and lists specific topics with the corresponding work package.

A Glossary of Terms is provided to explain terms and words which are unique to this equipment.

HEATER, WATER, LIQUID FUEL, M-80 AND M-85
GENERAL INFORMATION

SCOPE

This technical manual contains instructions for the operation, as well as preventive, and corrective maintenance of the M-80 and M-85 Water Heaters.

Type of Manual: Operator's, Unit and Direct Support Maintenance, Including Repair Parts and Special Tools List.

Model Number and Equipment Name:

Heater, Water, Liquid Fuel, M-80, P/N 6-1-6200, NSN 4520-01-162-0385
Heater, Water, Liquid Fuel, M-85, P/N 6-1-9912, NSN 4520-01-237-3719.

Purpose of Equipment: The M-80 and M-85 Water Heaters are designed to provide hot water to the Bath Unit, Portable, Automated; Multi-Head Model PBU-100 and Model HEI-100, and the Laundry Unit, Trailer Mounted, M-85, M-85-100, and M-85-200, respectively.

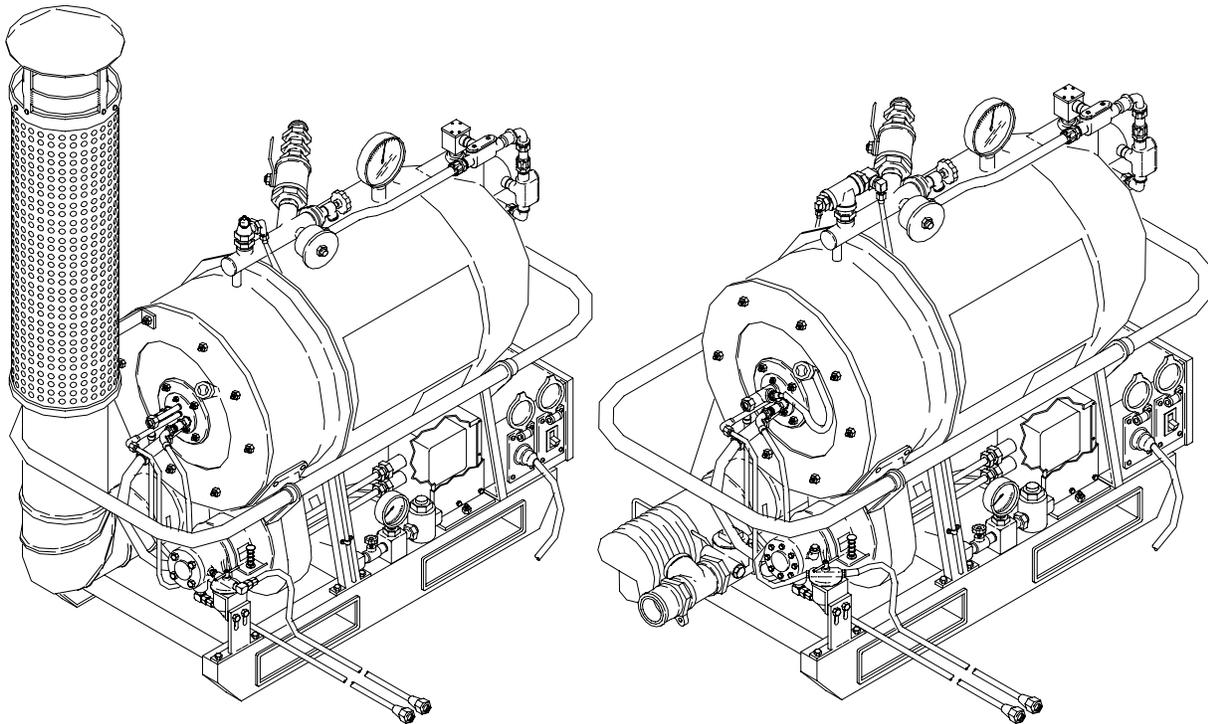

Heater, Water, Liquid Fuel, M-80

Heater, Water, Liquid Fuel, M-85

MAINTENANCE FORMS RECORDS AND REPORTS

Department of the Army forms and procedures used for equipment maintenance will be those prescribed by (as applicable) DA PAM 750-8, The Army Maintenance Management System (TAMMS) User’s Manual; DA PAM 738-751, Functional Users Manual for the Army Maintenance Management Systems – Aviation (TAMMS – A); or AR 700-138, Army Logistics Readiness and Sustainability.

REPORTING EQUIPMENT IMPROVEMENT RECOMMENDATIONS (EIRs)

If your M-80 or M-85 needs improvement, let us know. Send us an EIR. You, the user are the only one who can tell us what you don’t like about your equipment. Let us know why you don't like the design or performance. Put it on an SF368 Product Quality Deficiency Report. Mail it to: Commander U.S. Army Tank-automotive and Armament Command; ATTN: AMSTA-LC-R, Kansas St. Natick MA 01760-5052. We will send you a reply.

CORROSION PREVENTION AND CONTROL (CPC)

Corrosion Prevention and Control (CPC) of Army materiel is a continuing concern. It is important that any corrosion problems with this item be reported so that the problem can be corrected and improvements can be made to prevent the problem in future items.

While corrosion is typically associated with rusting of metals, it can also include deterioration of other materials, such as rubber or plastic. Unusual cracking, softening, swelling or breaking of these materials may be a corrosion problem.

If a corrosion problem is identified, it can be reported using SF 368, Product Quality Deficiency Report. Use of key words such as “corrosion”, “rust”, “deterioration”, or “cracking” will ensure that the information is identified as a CPC problem.

The form should be submitted to the address specified in DA PAM 750-8; The Army Maintenance Management System (TAMMS) User’s Manual. This form should be submitted to: Commander, U.S. Army Tank-automotive and Armament Command, ATTN: AMSTA-LC-R, Kansas Street, Natick, MA, 01760-5052.

WARRANTY INFORMATION

Both models of the water heater are warranted for 12 months. The warranty starts on the date found in block 23, DA Form 2408-5 in the Logbook. Report all defects in material and workmanship to your supervisor, who will take appropriate action.

DESTRUCTION OF ARMY MATERIEL TO PREVENT ENEMY USE

For procedures to destroy this equipment to prevent its use by the enemy refer to TM 750-244-3, Procedures for Destruction of Material to Prevent Enemy Use.

NOMENCLATURE CROSS-REFERENCE LIST

Common Name	Official Name
Skid	Water Heater Skid Assembly
Scanner	Ultra-violet or Infra-red scanner

LIST OF ABBREVIATIONS/ACRONYMS			
AAL	Additional Authorization List	MSDS	Material Safety Data Sheet
BII	Basic Issue Item	MTOE	Modified Table of Org and Equipment
COEI	Component of end item	NBC	Nuclear, Biological, Chemical
CPC	Corrosion Prevention Control	NIIN	National Item Identification Number
cm	Centimeter	NSN	National Stock Number
°C	Degrees Celsius (Centigrade)	PMCS	Preventive Maintenance Checks and Services
°F	Degrees Fahrenheit	P/N	Part Number
EIR	Equipment Improvement Recommendation	PSI	Pounds per square inch
GFCI	Ground Fault Circuit Interrupt	P/O	Part of
GPM	Gallons per Minute	POL	Petroleum, Oil and Lubricant
hr	Hour	QD	Quick Disconnect
IAW	In Accordance With	RCPT	Receptacle
ISO	International Standards Organization	RPSTL	Repair Parts and Special Tools List
in	Inches	SMR	Source, Maintenance, and Recoverability
IR	Infrared	TMDE	Test, Measurement, Diagnostic Equipment
Kg	Kilogram	TOE	Table of Organization and Equipment
KW	Kilowatt	U/M	Unit of Measure
lbs	Pounds	UOC	Usable On Code
lt	Liter	UV	Ultraviolet
MOS	Military Occupational Specialty	VAC	Volt Alternating Current
		WP	Work Package

SAFETY, CARE AND HANDLING

Always pay attention to **Warnings, Cautions** and **Notes** appearing throughout the manual. They will appear prior to applicable procedures. Ensure you read and understand their content to prevent serious injury to yourself and others, or damage to equipment.

CHAPTER 1

DESCRIPTION AND THEORY OF OPERATION FOR M-80 AND M-85 LIQUID FUEL WATER HEATER

**HEATER, WATER, LIQUID FUEL, M-80 AND M-85
EQUIPMENT DESCRIPTION AND DATA**

EQUIPMENT CHARACTERISTICS, CAPABILITIES AND FEATURES

Characteristics	Capabilities and features
<ul style="list-style-type: none"> • Portable (The water heater weighs approximately 465 lbs (211Kg) and requires material handling equipment to move). 	<ul style="list-style-type: none"> • Delivers 9 Gallons of water per minute at temperatures between 100⁰ F and 210⁰ F (37⁰ C and 98⁰ C).
<ul style="list-style-type: none"> • Mounted on skid with forklift pockets. 	<ul style="list-style-type: none"> • Automatic Flame Safeguard Control ensures safe operation.
<ul style="list-style-type: none"> • Simple to set up, operate and maintain. 	<ul style="list-style-type: none"> • Drum Fill Adapter Assembly permits use of 50 Gallon fuel drum for extended operations.
<ul style="list-style-type: none"> • Temperature control provides hot water at temperatures between 100⁰ F and 210⁰ F (37⁰ C and 98⁰ C). 	<ul style="list-style-type: none"> • Low fuel/loss of flame audio alarm alerts operator.
<ul style="list-style-type: none"> • Operates on Diesel VV-F-800, DF-A, DF-1, DF-2, Jet Fuel MIL-T-5624 JP-4, JP-5, Jet Fuel MIL-T-83133, JP-8 and Fuel No. 2 Commercial. 	<ul style="list-style-type: none"> • Hour meter accumulates total operating hours.
<ul style="list-style-type: none"> • Integral pressure relief valve activates in an overpressure situation. 	<ul style="list-style-type: none"> • The M-80 water heaters are used with Model PBU-100 and HEI-100 Bath Units, the Containerized Shower, and Force Provider Kitchen, Shower, and Laundry facilities.
<ul style="list-style-type: none"> • Operates on 208 VAC power from either a commercial source or a generator. 	<ul style="list-style-type: none"> • The M-85 water heaters are used with the Trailer Mounted M-85 Series Laundries.

LOCATION AND DESCRIPTION OF MAJOR COMPONENTS

Water Vessel. The vessel (1) contains the water to be heated.

Temperature Limit Control Assembly. This assembly (2) consists of the operating and high limit controls. The operating control regulates the burner to maintain the water temperature between 100^o F and 210^o F (37^o C and 98^o C). The high limit control deactivates the fuel solenoid valve when the water temperature exceeds 190^o F (88^o C).

Control Box Assembly. This assembly (3) contains the operating controls, including the power switch, flame safeguard control, motor contactor reset, solenoid, low water relay, flame failure alarm, twist-lock receptacle, and hour meter.

Ignition Transfer Assembly. This assembly (4) contains the transformer ignition wiring.

Ignition Cables. The ignition cables (5) conduct power from the transformer to the spark plugs on the burner assembly.

Fuel Pressure Gage. The gage (6) indicates fuel pressure during operation.

Skid Assembly. The skid assembly (7) provides a mounting platform for the heater. It features forklift pockets for use with powered or manual forklifts.

Blower Assembly. The blower (8) assembly provides air to the burner. It also includes the blower and fuel pump motor, fuel filter, fuel pump, and adjustable air shutter assemblies.

Fuel Feeder Hose. This hose (9) conveys fuel from the source (through Drum Fill Adapter Assembly) to the burner.

Fuel Return Hose. This hose (10) returns fuel overflow to the fuel source (through Drum Fill Adapter Assembly).

Lower Manifold Assembly. The manifold (11) serves as the water intake point of the heater to which the water hose is connected.

Burner Assembly. The burner assembly (12) consists of the electrode holder and sparkplugs, ultra-violet (UV), or infrared (IR) Scanner, ignition sight glass, and fuel nozzle assembly

Sight Glass Assembly. The sightglass assembly (13) allows operator to observe ignition inside burner assembly.

Smoke Stack and Guard Assembly (M-80). The smoke stack and guard assembly (14) evacuates burner exhaust gases on M-80 Water Heater.

Exhaust Duct Assembly (M-85). The exhaust duct assembly (15) evacuates burner exhaust gases on M-85 Water Heater.

Pressure Relief Valve. This valve (16) activates and relieves the pressure when the internal temperature exceeds the prescribed limit.

Upper Manifold Assembly. The manifold (17) provides for hose connection to draw hot water. It incorporates the pressure relief valve and high limit control.

Ball Valve. A ball valve (18) provides a quick acting shutoff for hot water leaving the heater.

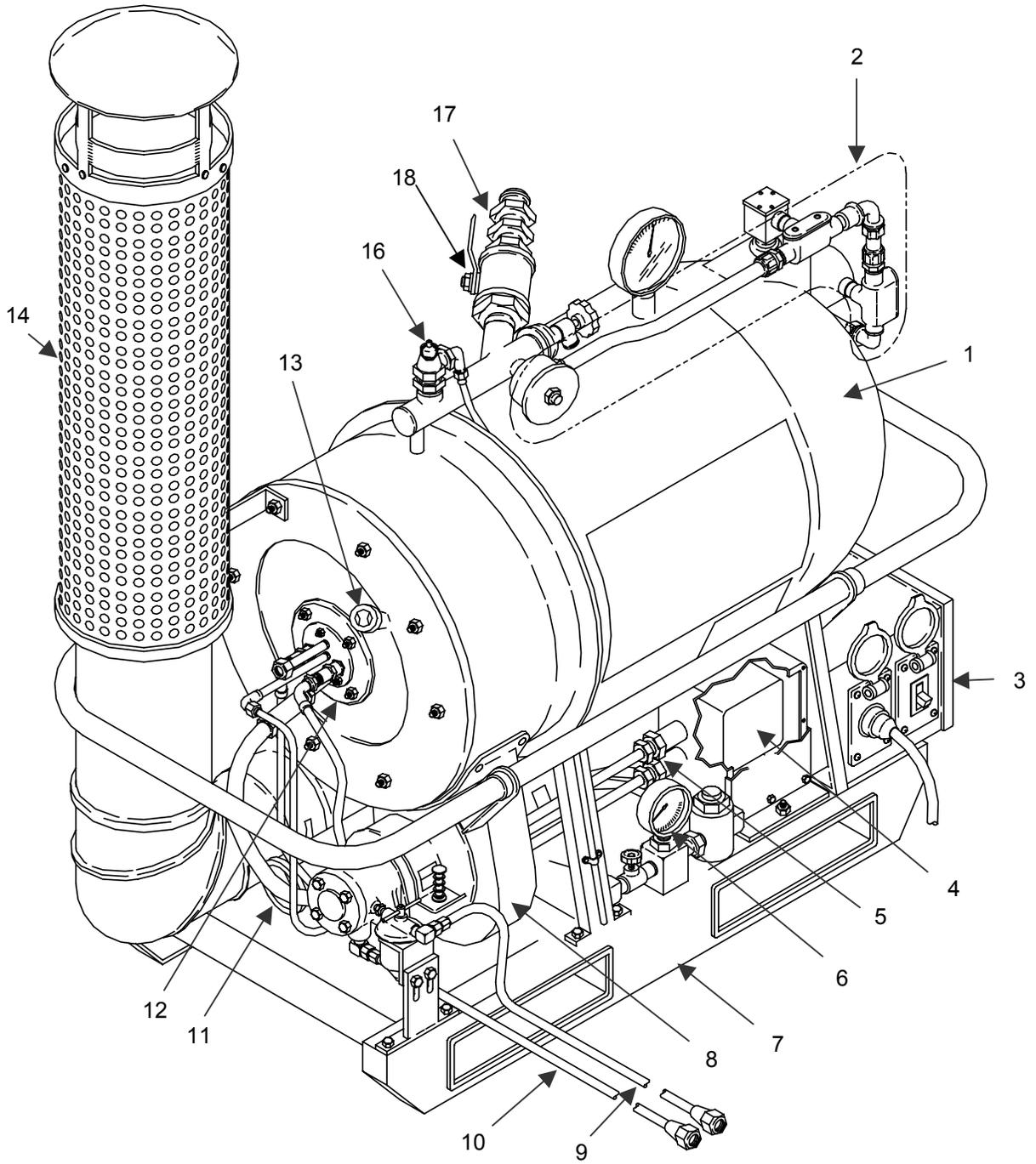

M-80 Water Heater

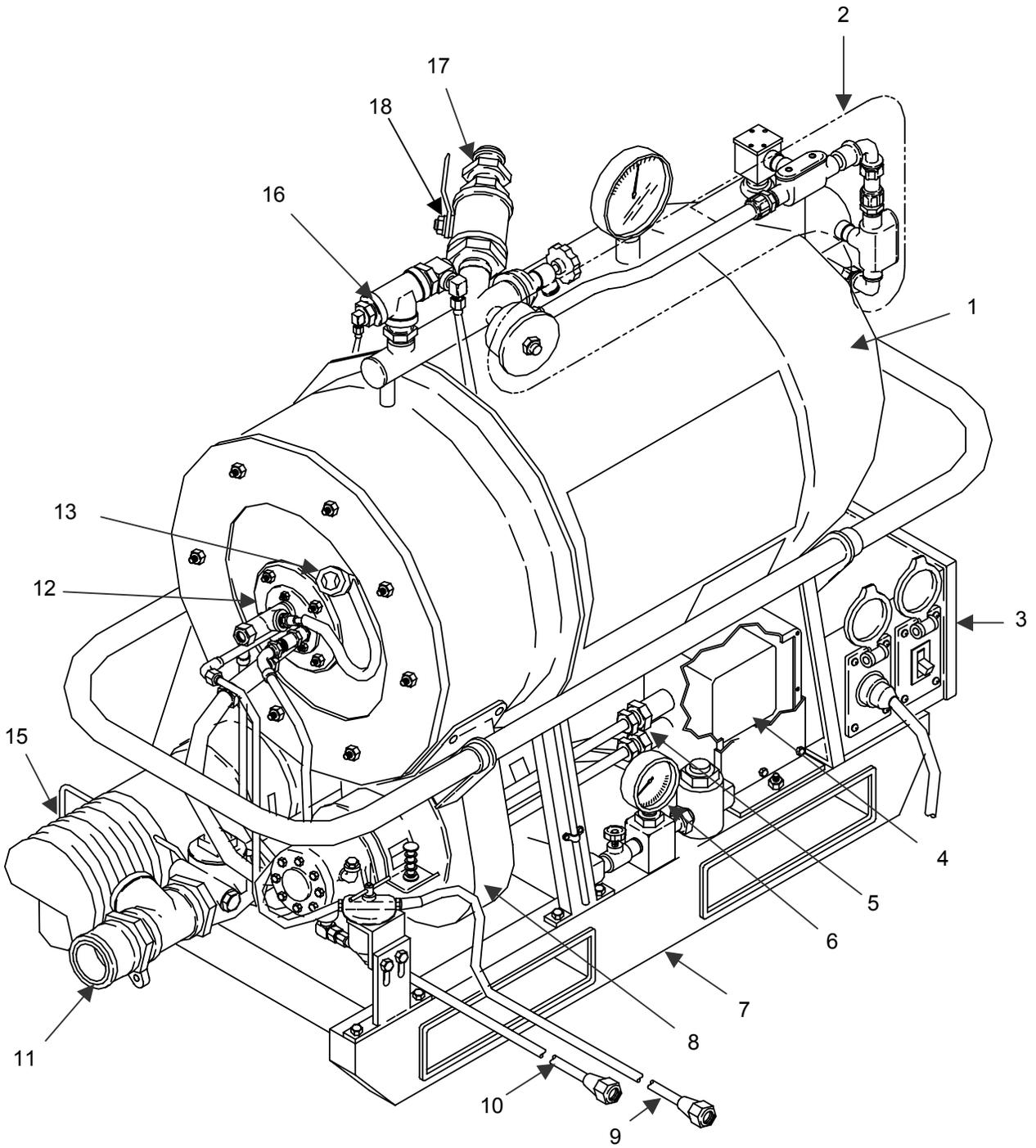

M-85 Water Heater

COMMON TOOLS AND EQUIPMENT

For authorized common tools and equipment, refer to the Modified Table of Organization and Equipment (MTOE), CTA 50-970, Expendable/Durable Items (Except: Medical, Class V, Repair Parts, and Heraldic Items), or CTA 8-100, Army Medical Department Expendable/Durable Items, as applicable to your unit.

Special Tools, TMDE, and Support Equipment for the M-80 and M85 Water Heaters are listed in Work Package 0038 00.

Repair parts are listed and illustrated in the Repair Parts and Special Tools List (RPSTL) located in Work Packages 0040 00 through 0052 00.

DIFFERENCES BETWEEN MODELS

Both types of heaters are based on the same design, however, minor differences in the following component assemblies exists due to different heater applications:

- Upper Manifold Assembly
- Lower Manifold Assembly
- Exhaust Duct Assembly
- Burner Head Assembly
- Blower Assembly
- Pressure Relieve Valve Assembly

The specific differences of these component assemblies are addressed where applicable throughout this manual.

EQUIPMENT DATA

External dimensions:

Length 52 inches 1.32 meters
 Width 27 inches 69 centimeters
 Height 47 inches 1.12 meters

Weight:

Approximate 465 lbs 211 kilograms

Required electrical input:

Model M-80 and M-85 Heaters 208 VAC, 3 Phase

Capacity:

Water 23.7 Gallon 89.7 Liters
 High 120 PSI

Blower and Fuel Pump Motor

Power Rating 1/3 Horsepower
 Motor Speed 3450 rpm

Fuel Pump

Type 2-stage gear
 Pressure 0-150 PSI (0-1034 kPa)

Fuel Requirements:

Operates on Diesel VV-F-800, DF-A, DF-1, DF-2
 Jet Fuel MIL-T-5624 JP-4, JP-5
 Jet Fuel MIL-83133 JP-8 and Fuel No. 2 Commercial

REFERENCES. The following list contains publications necessary, or helpful, when operating the M80 and M85 Water Heater. These references are also listed in work package 0036 00.

Equipment/Materials	Technical Manual Title	TM Number
Bath Units, AMH and HEI	Operator, Organizational, Direct Support, and General Support Maintenance Manual Bath Unit, Portable, Automated, Multi-Head Model PBU-100 and Model HEI-100	TM 10-4510-206-14
M-85 Series Laundry	Operator's Manual, Laundry Unit, Trailer Mounted, M85, M85-100, M85-200	TM 10-3510-222-10
	Unit and Direct Support Maintenance Manual, Laundry Unit, Trailer Mounted, M85, M85-100, M85-200	TM 10-3510-222-24
	Repair Parts and Special Tools List, Laundry Unit, Trailer Mounted, M85, M85-100, M85-200	TM 10-3510-222-24P

**HEATER, WATER, LIQUID FUEL, M-80 AND M-85
THEORY OF OPERATION**

THEORY OF OPERATION

General. The M-80 and M-85 Water Heaters are designed for use with the Model PBU-100 and HEI-100 Bath Units and the Trailer Mounted M-85 series laundries, respectively. They are based on the same design and have only slight physical variations that accommodate their different application. Both models deliver approximately 9 gallons of water per minute at temperatures between 100⁰ F and 210⁰ F (37⁰C and 98⁰C). The concept of operation involves a skid-mounted vessel holding approximately 23 Gallons of water being heated by a liquid fuel burner. A motor driven fuel pump supplies diesel fuel to the burner. A blower assembly with an adjustable air shutter, provides the required air to the combustion chamber. Combustion is initiated when the operator activates the control switch that sends 110VAC power to the transformer which powers two spark plug electrodes. The operator can observe the electrode spark and combustion chamber through separate sight glasses. Combustion gases are vented through a stack (M-80) or a hose (M-85 Assembly). Water enters and exits the vessel through separate manifolds as needed.

Skid Assembly

The skid is a welded assembly and consists of the basic skid and the handrail. The skid incorporates forklift pockets for handling the heater and provides a stable platform for heater operation.

Power System

The M-80 and M-85 Water Heaters operate on 208 VAC power. A power source, either commercial or appropriate generator, must be connected to the receptacle on the control box assembly. When the control switch is in the ON position, power is conveyed to the sparkplug electrodes through a transformer and ignition cables.

Fuel System

Both water heaters operate on the fuels specified under Equipment Data in work package 0002 00. Fuel is drawn by the fuel pump through the fuel supply hose connected to the fuel filter and the **SUPPLY** fitting on the Drum Fill Adapter installed on either a 50-gallon fuel drum or a 5-gallon military gas can. Excess fuel is returned through a fuel return hose connected to the bottom of the fuel pump and the **RETURN** fitting on the Drum Fill Adapter.

Burner Head Assembly

The burner head assembly at the center of the combustion chamber serves as a mounting platform for the fuel nozzle, two sparkplug electrodes, the burner assembly sight glass, and the UV or IR Scanner that is part of the flame safeguard control system.

Flame Safeguard Control

The flame safeguard control system uses a UV or IR scanning device mounted on the burner head assembly to monitor the flame within the combustion chamber. New heaters are equipped with an IR control system. The flame safeguard control system shuts the heater down when combustion fails.

Exhaust Devices

Different exhaust devices are used for the M-80 and M-85 heaters. While the M-80 uses a vertical stack assembly, the M-85 operates with a flexible metallic hose assembly.

Temperature Control System

The system consists of the operating and high limit controls. The operating control maintains water temperature between 100⁰F and 210⁰F. The high limit control will deactivate the fuel solenoid valve when the temperature exceeds 190⁰F.

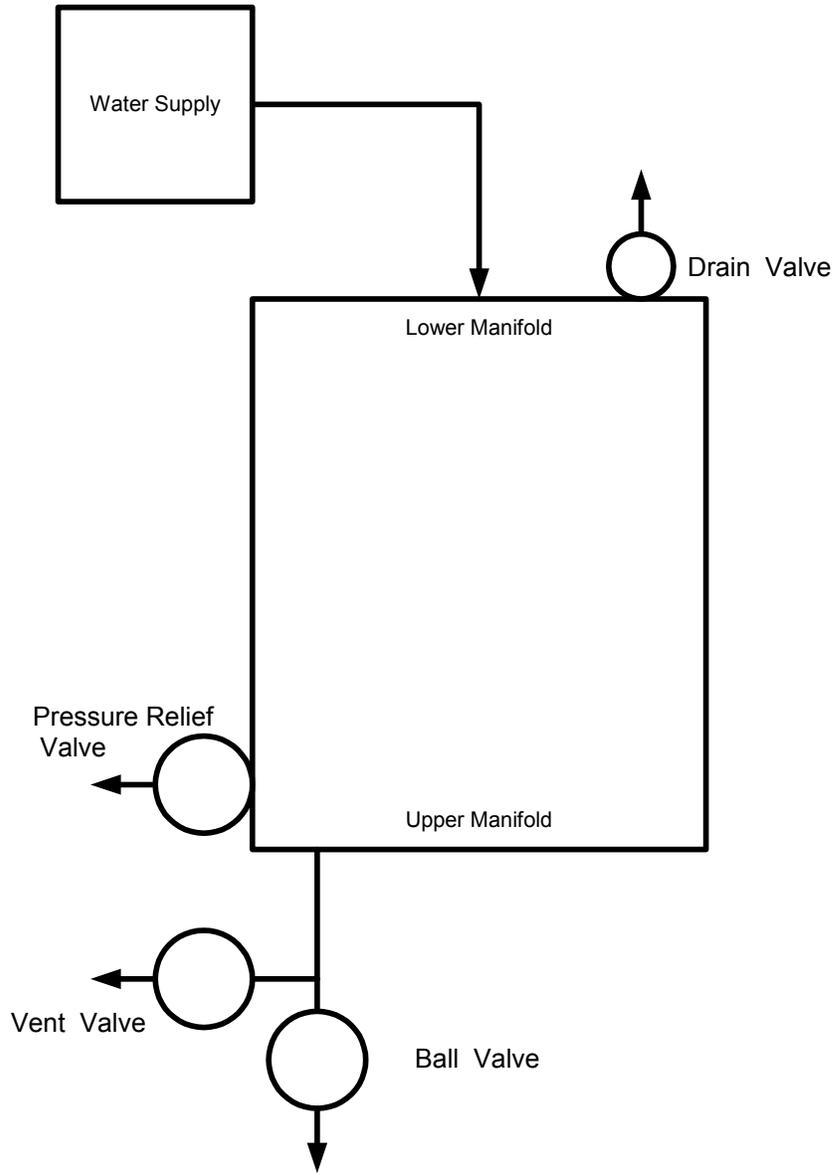

Water Flow through the M-80/M-85 Water Heater

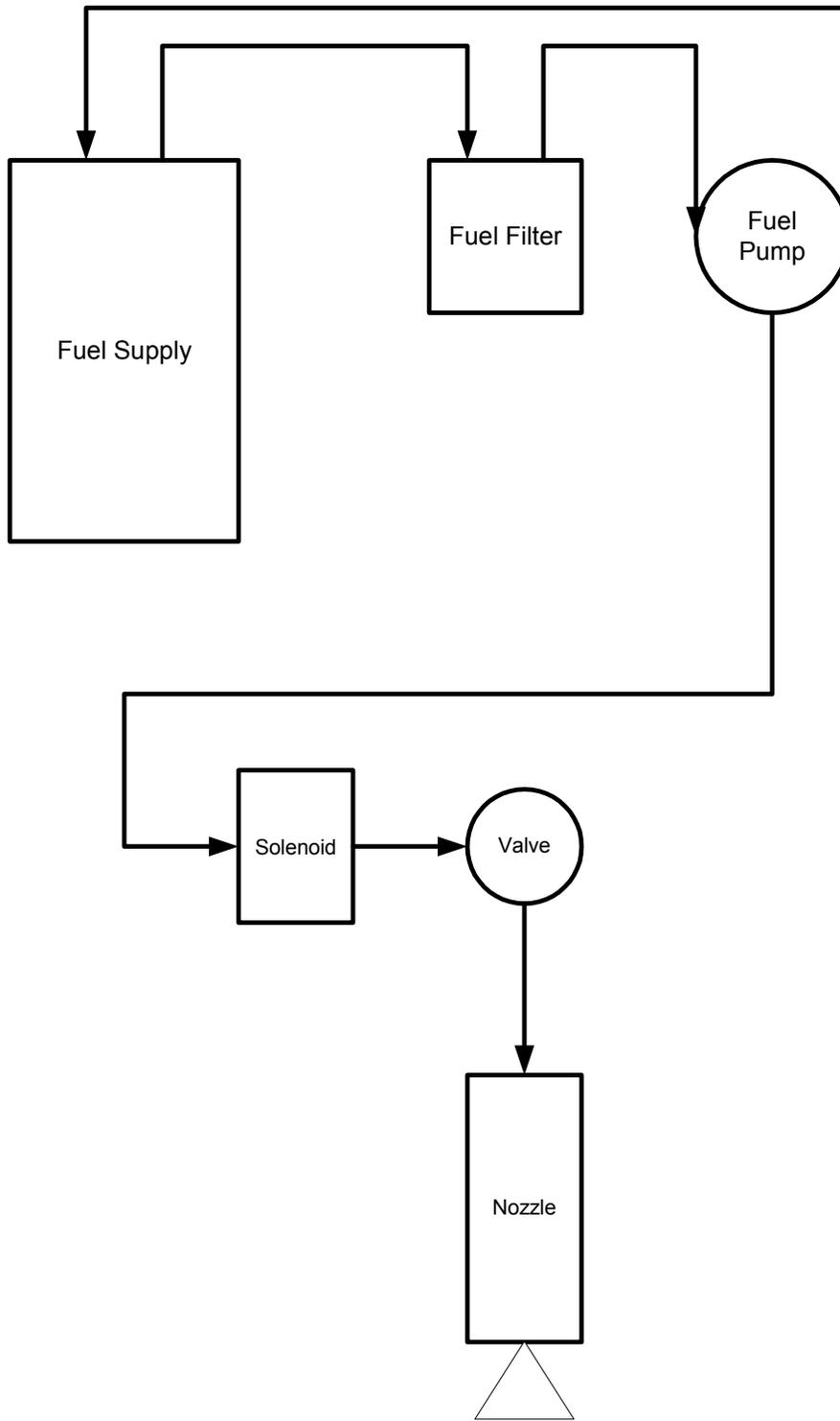

Fuel Flow through the M-80/M-85 Water Heater

CHAPTER 2

OPERATOR INSTRUCTIONS
FOR
M-80 AND M-85 LIQUID FUEL WATER HEATER

**HEATER, WATER, LIQUID FUEL, M-80 AND M-85
DESCRIPTION AND USE OF OPERATOR CONTROLS AND INDICATORS**

GENERAL

This work package contains information on the controls and indicators of the water heaters. The illustration below shows the location of the controls and indicators found on the water heaters. Subsequent illustrations show controls and indicators in detail and tables explain their specific function.

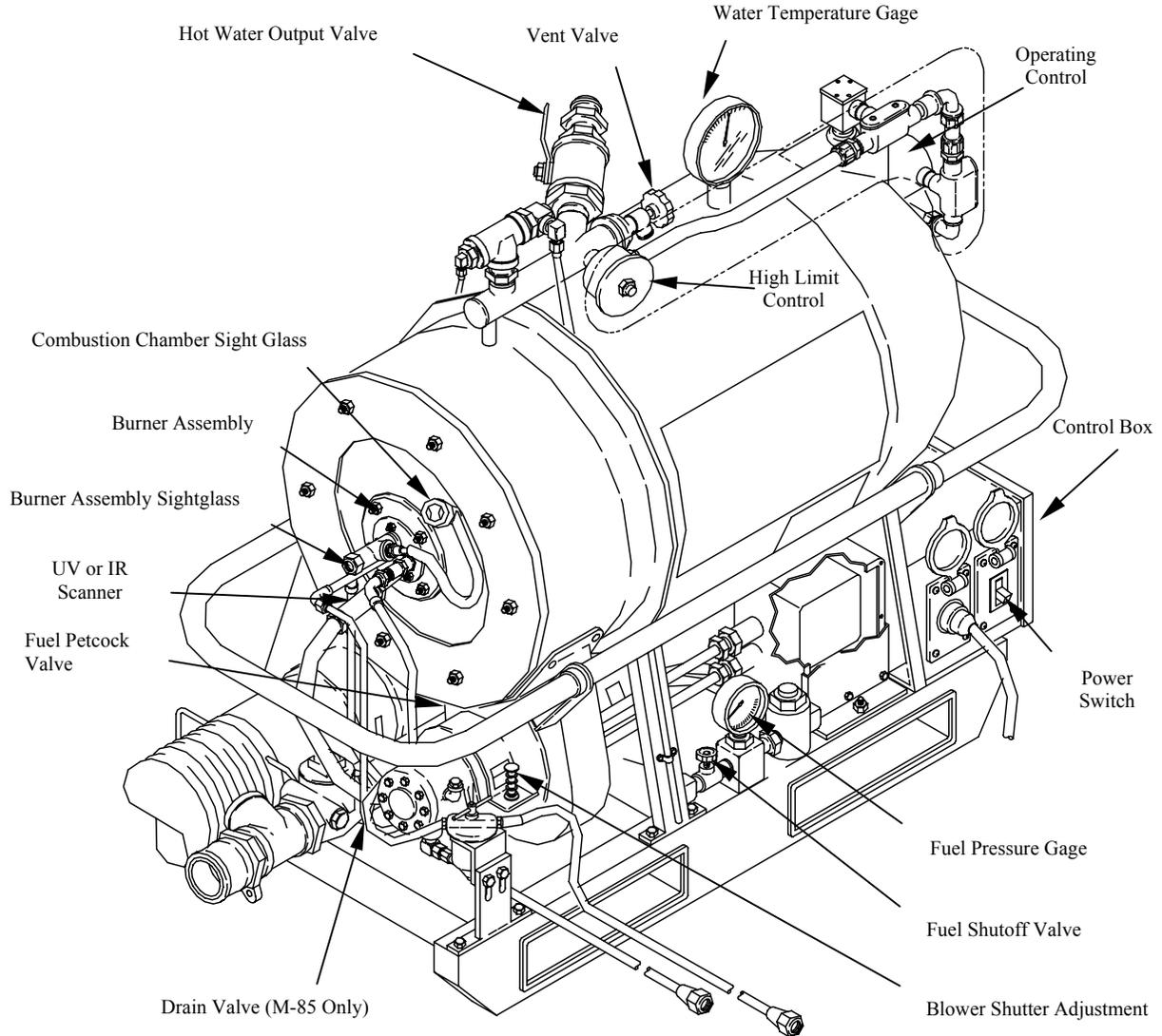

Location of M-80 and M-85 Controls and Indicators

TEMPERATURE LIMIT CONTROL ASSEMBLY

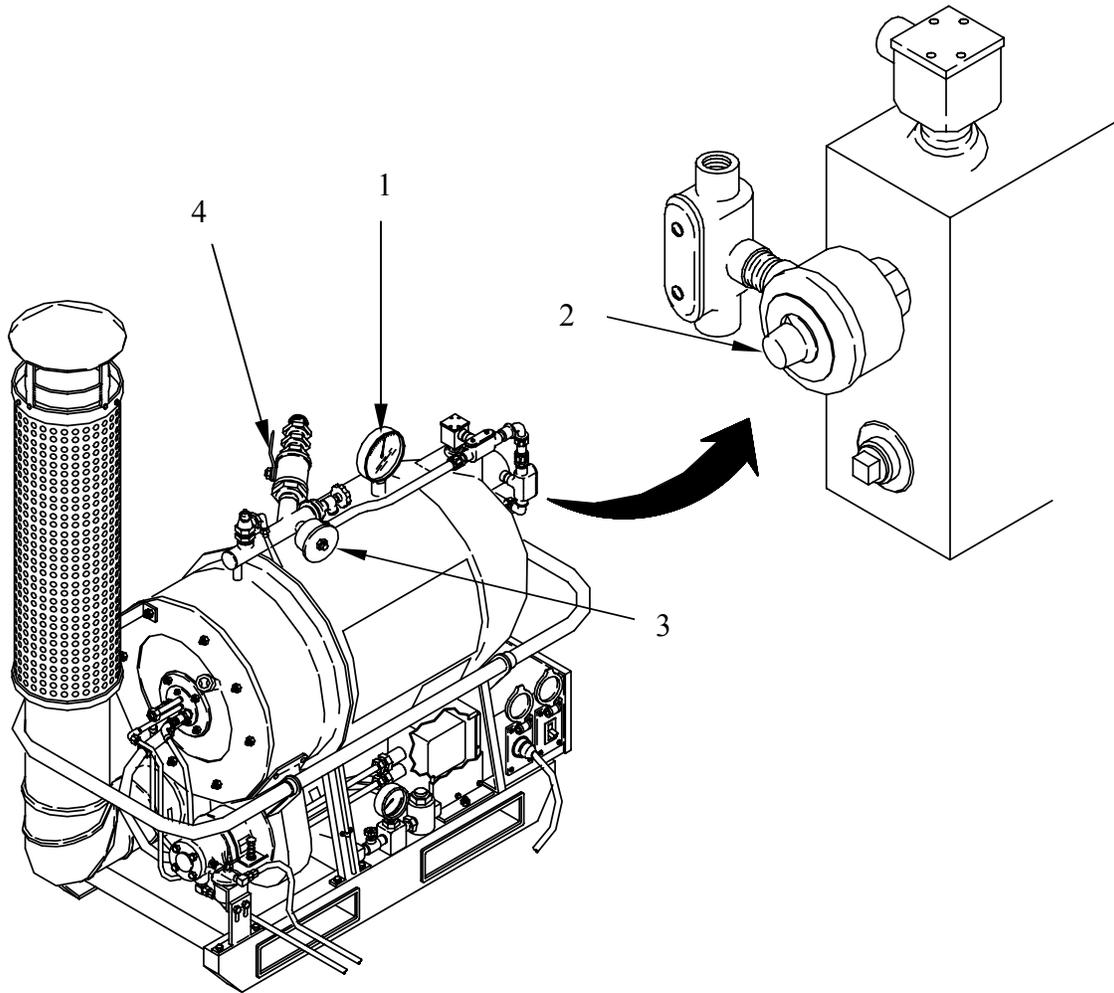

Table 1. Temperature Limit Control Assembly Controls and Indicators.

Key	Item	Function
1	Water Temperature Gage	Indicates temperature of water inside water heater
2	Operating Control	Maintains selected water temperature
3	High Limit Control	Deactivates water heater if temperature reaches 190° F
4	Hot Water Output Valve	Controls flow of hot water

BURNER ASSEMBLY

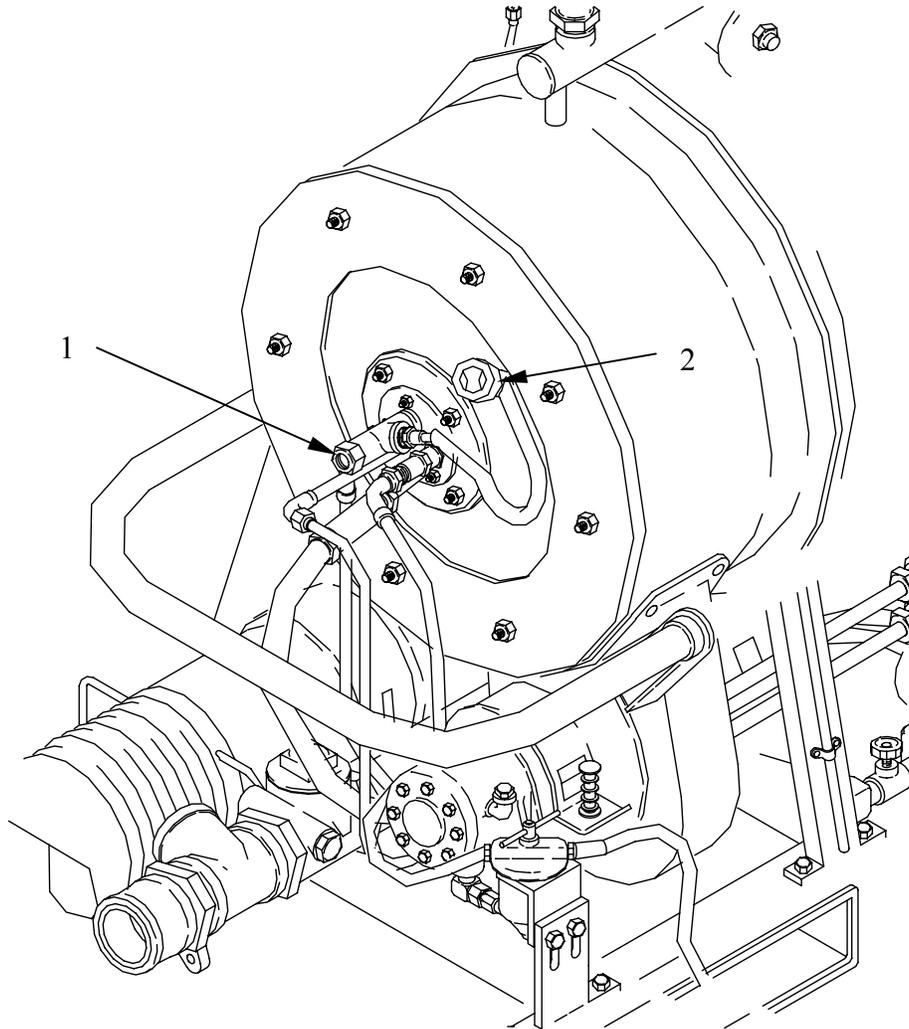

Table 2. Burner Assembly Controls and Indicators.

Key	Item	Function
1	Burner Assembly Sight Glass	Observation of electrodes sparking
2	Combustion Chamber Sight Glass	Observation of combustion

CONTROL BOX ASSEMBLY

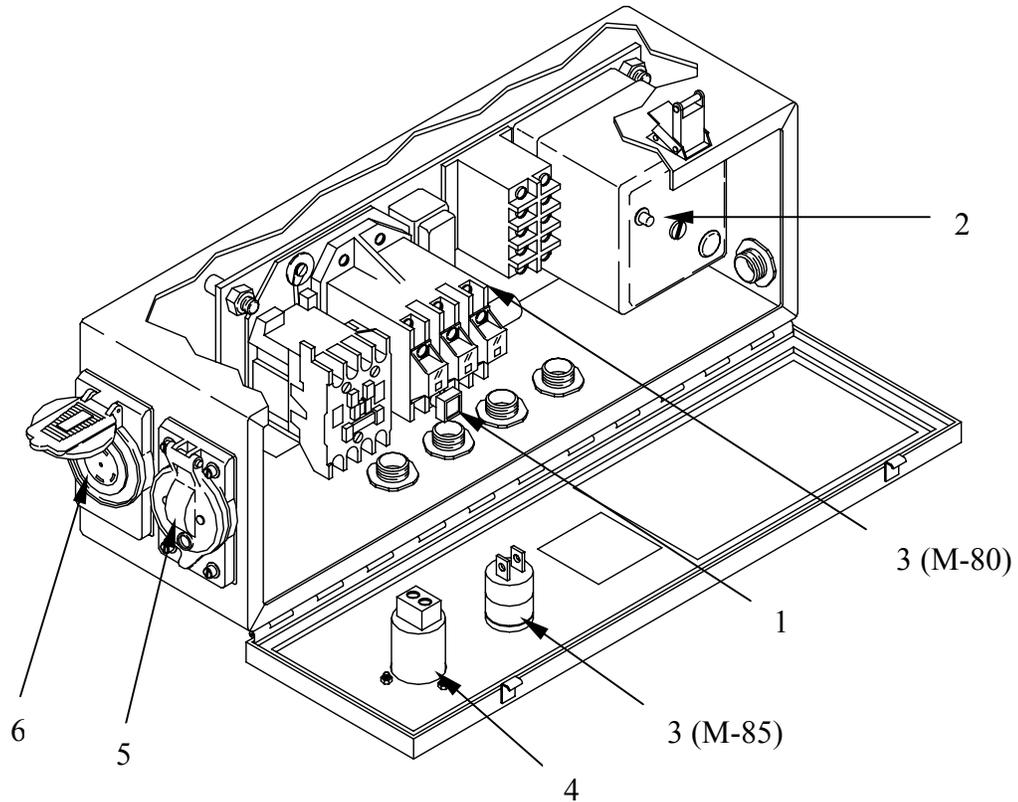

Table 3. Control Box Assembly Controls and Indicators.

Key	Item	Function
1	Motor Contactor Reset	Overload reset device breaks circuit to blower motor
2	Flame Safeguard	Lockout switch for flame safeguard
3	Buzzer (Alarm)	Indicates low water condition or flame safeguard lockout
4	Hour Meter	Indicates cumulative time burner has been in operation
5	Power Switch	Controls electrical power to water heater
6	Twist-Lock Receptacle	Power inlet device for water heater

FUEL / AIR SHUTTER SYSTEM

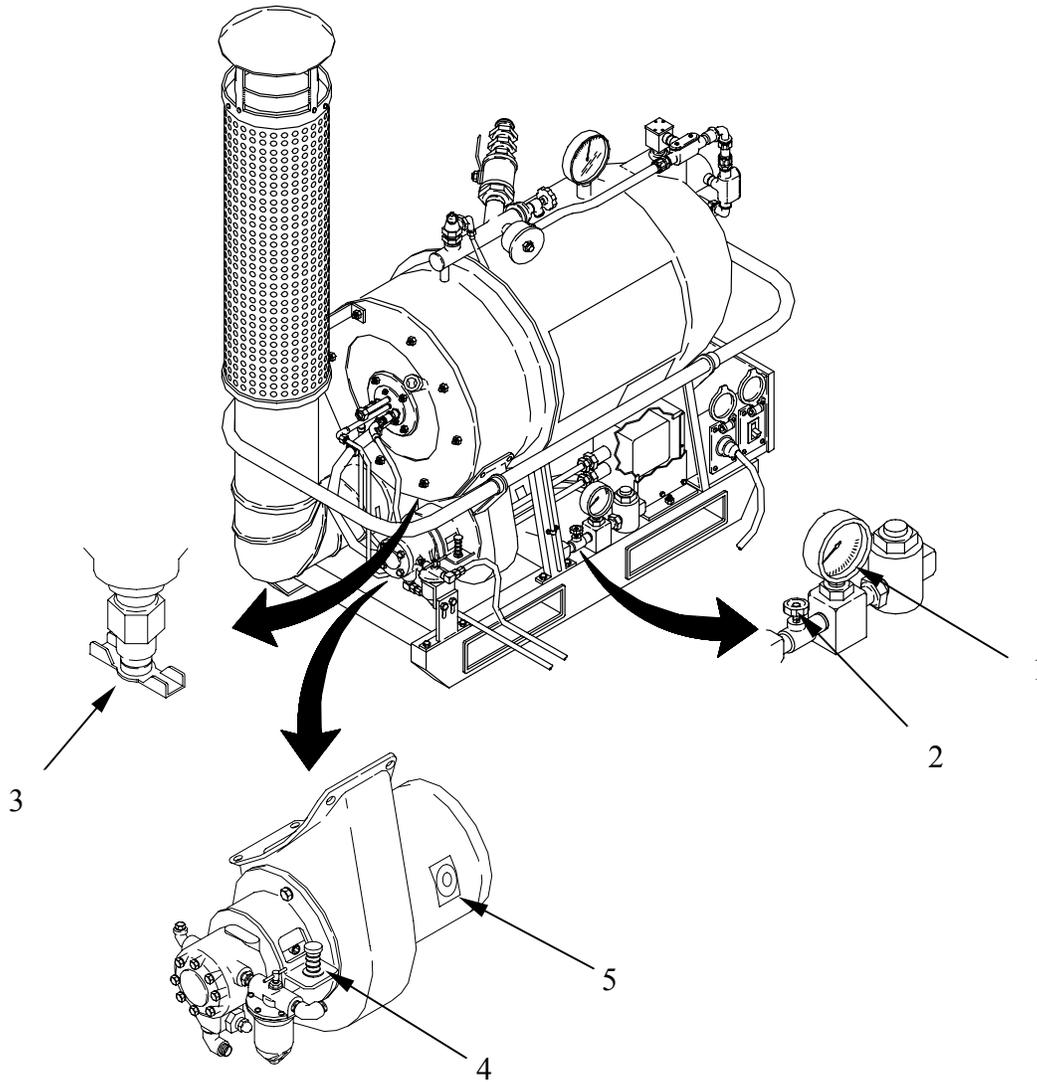
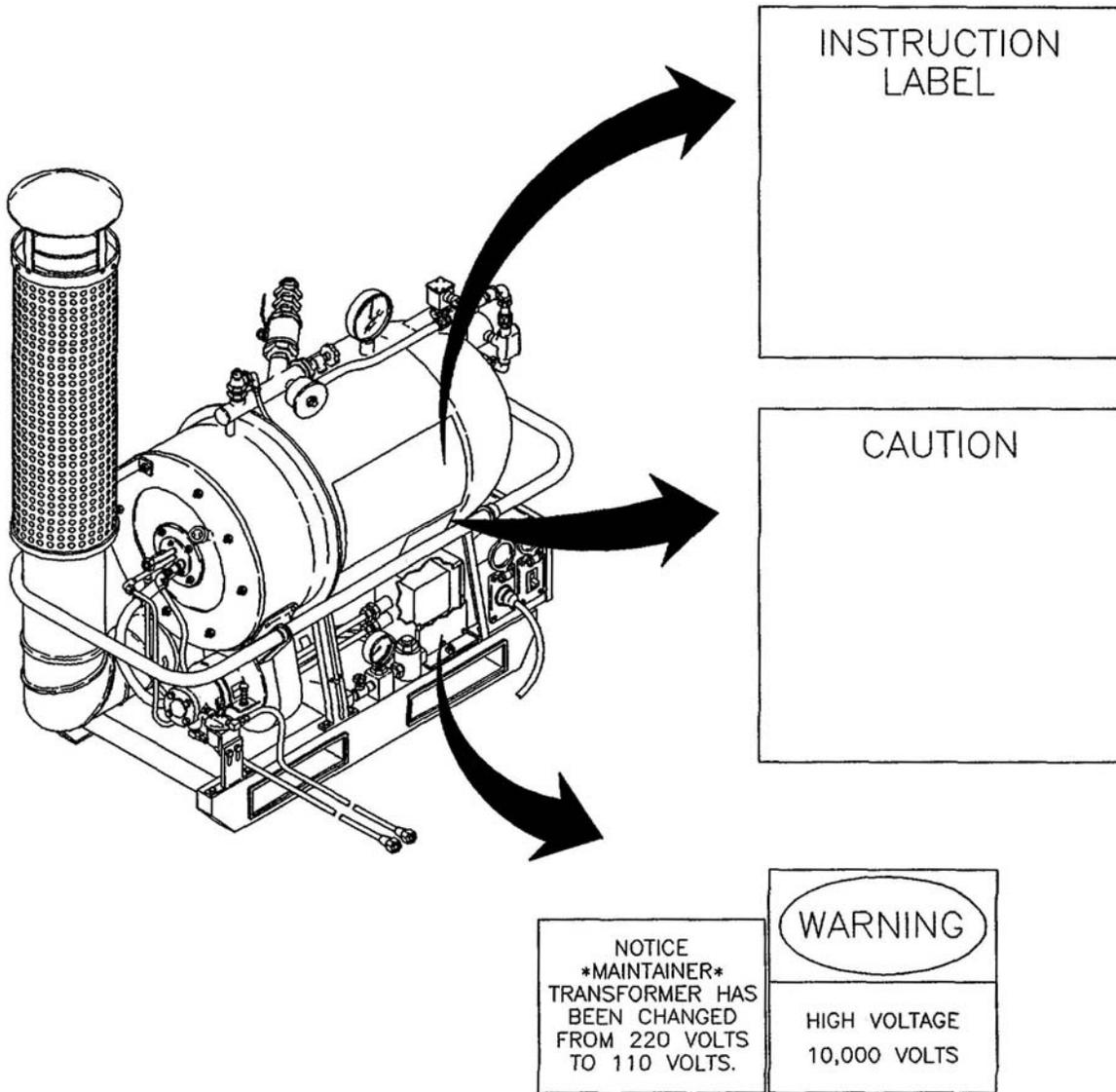

Table 4. Fuel/Air Shutter System Controls.

Key	Item	Function
1	Fuel Pressure Gage	Indicates pressure of fuel supplied to the burner
2	Fuel Shutoff Valve	Controls fuel flow to burner
3	Fuel Petcock Valve	Drains excess fuel from water vessel
4	Air Shutter Adjustment	Controls amount of air to burner
5	Blower Motor Reset	Internal overload protection for motor

DECALS AND INSTRUCTION PLATES



Placement of Instruction Plates and Decals on the M-80 / M-85 Water Heater

WIRING
DIAGRAM

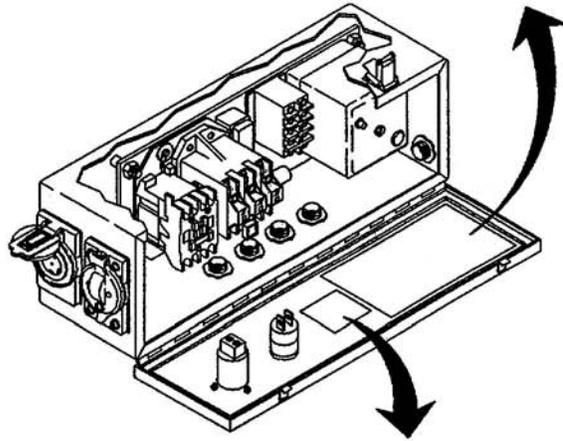

NOTICE
MAINTAINER
TRANSFORMER HAS
BEEN CHANGED
FROM 220 VOLTS
TO 110 VOLTS.

Placement of Decal in the M-80 / M-85 Water Heater Control Box

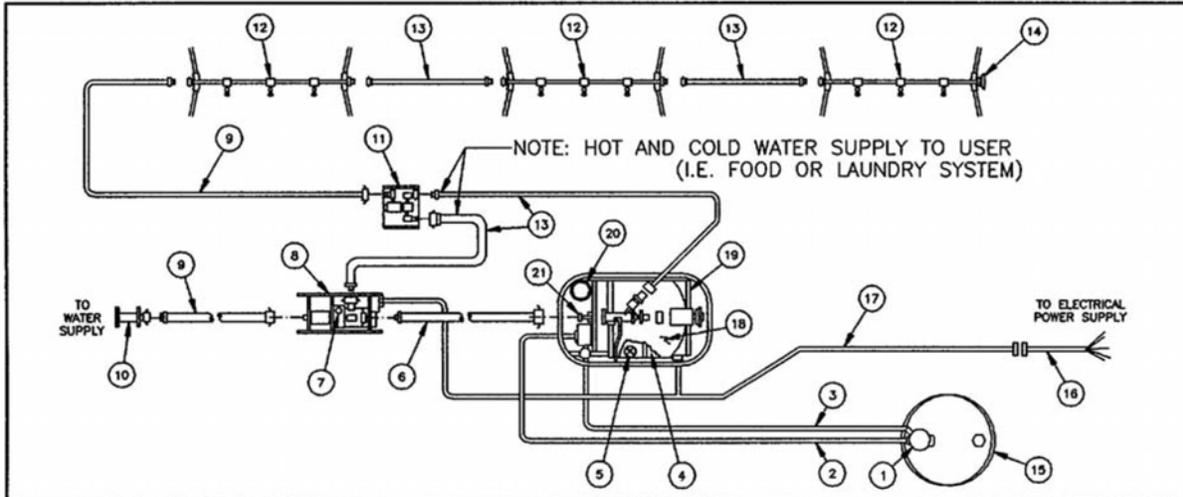

**HEATER, WATER, LIQUID FUEL, M-80
SET UP FOR USE WITH BATH UNIT AMH**

INSTRUCTIONS

HEATER, WATER, LIQUID FUEL, M-80 OPERATION

1. LOCATE PUMP (8) 20 FT FROM WATER SOURCE.
2. CONNECT STRAINER (10) TO END OF 1" X 25' HOSE AND OTHER END TO SUCTION PORT OF PUMP (8).
3. INSTALL SMOKE STACK GUARD ASSY. (20)
4. CONNECT 1 1/2" X 6' HOSE (6) TO PUMP (8) AND HEATER (18).
5. CONNECT 1" X 7.5' HOSE (13) FROM HEATER (18) TO HOT FITTING OF MIXING VALVE (11) AND 1" X 7.5' HOSE (13) FROM OUTLET OF PUMP (8) TO COLD FITTING OF MIXING VALVE (11).
6. ERECT SHOWER-HEAD ASSEMBLY (12) AS REQUIRED. USE 1" X 7.5' HOSE (13) TO CONNECT EACH ASSEMBLY. USE CAP (14) TO PLUG END.
7. SCREW DRUM FILL ADAPTER ASSY (1) INTO A 55 GAL DRUM (15)
8. CONNECT FUEL LINE (3) FROM PUMP STRAINER TO SUCTION FITTING OF DRUM FILL ADAPTER ASSEMBLY (1). CONNECT FUEL LINE (2) FROM PUMP TO RETURN FITTING.
9. CONNECT WIRING HARNESS (16) (17) TO HEATER, PUMP AND SOURCE. GREEN WIRE IS EQUIPMENT GROUND - WHITE IS NEUTRAL.
10. FUEL: DIESEL (W-D-800) OR ANY GASOLINE. SEE CAUTION PLATE IF GASOLINE IS USED.
11. ELECTRICAL: 200V, 3PH, 60HZ, 5 WIRE, (GREEN-GROUND) (WHITE-NEUTRAL)

1. TURN ON ELECTRICAL POWER WITH PUMP AND HEATER SWITCH OFF.
2. MOMENTARILY TURN ON PUMP SWITCH (8) AND CHECK FOR CORRECT ROTATION, SHOWN BY ARROWS. IF INCORRECT, REVERSE ANY TWO OF THE THREE POWER LINES AT THE GENERATOR.
3. REMOVE PUMP PRIME CAP (7) AND FILL WITH WATER. START PUMP AND ONCE SYSTEM IS FILLED WITH WATER STOP PUMP.
4. CLOSE FUEL VALVE (5) AND TURN ON HEATER SWITCH, PUMP IS PRIMED WHEN PRESSURE GAUGE (4) READS 100 PSI. IT MAY BE NECESSARY TO RESET THE FLAME SAFEGUARD CONTROL (19) (LOCATED IN CONTROL BOX) AS FUEL PUMP WILL ONLY RUN FOR 20 SECONDS WITHOUT FIRE (BUZZER WILL SOUND IF FLAME SAFEGUARD CONTROL REQUIRES RESETTING).
5. WITH FUEL PUMP RUNNING, CHECK FOR THE ELECTRODE SPARK (21). OPEN AIR SHUTTER HALF WAY.
6. OPEN FUEL VALVE, BURNER FLAME SHOULD START.
7. ADJUST AIR SHUTTER SO THAT NO SMOKE IS VISIBLE FROM STACK.
8. BURNER SHOULD OPERATE UNTIL WATER TEMPERATURE REACHES 160°F.
9. BUZZER WILL ALSO SOUND IF HEATER IS LOW ON WATER.

Instruction Plate for the M-80 / M-85 Water Heater

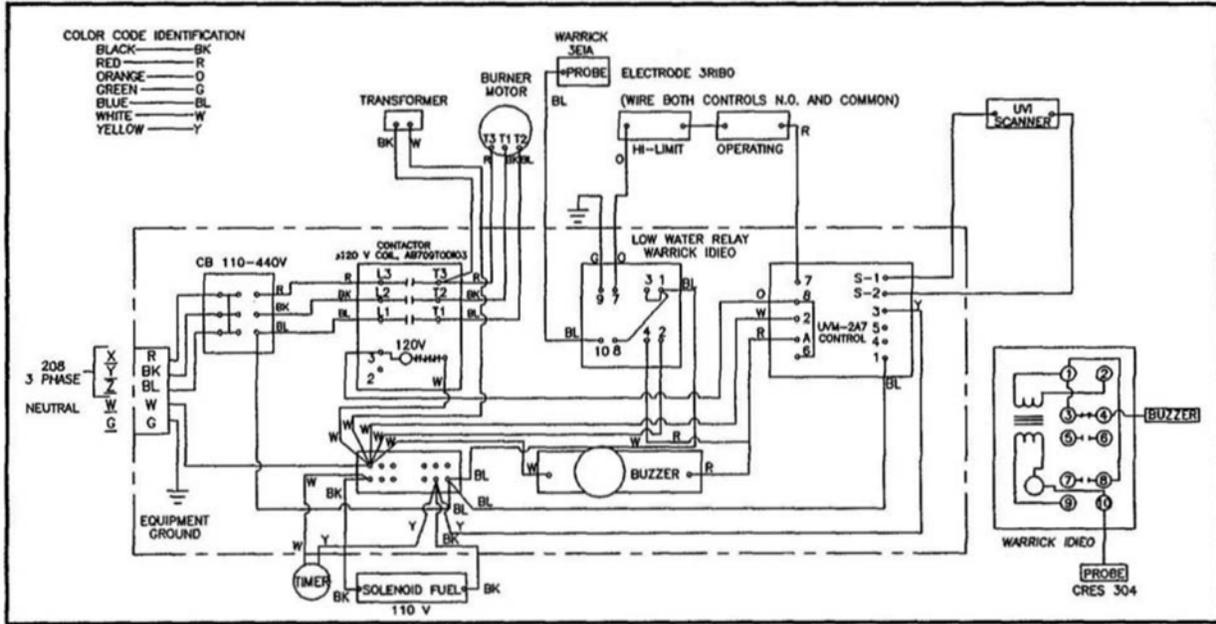

Wiring Diagram Decal for M-80 Water Heaters with 110 VAC transformer

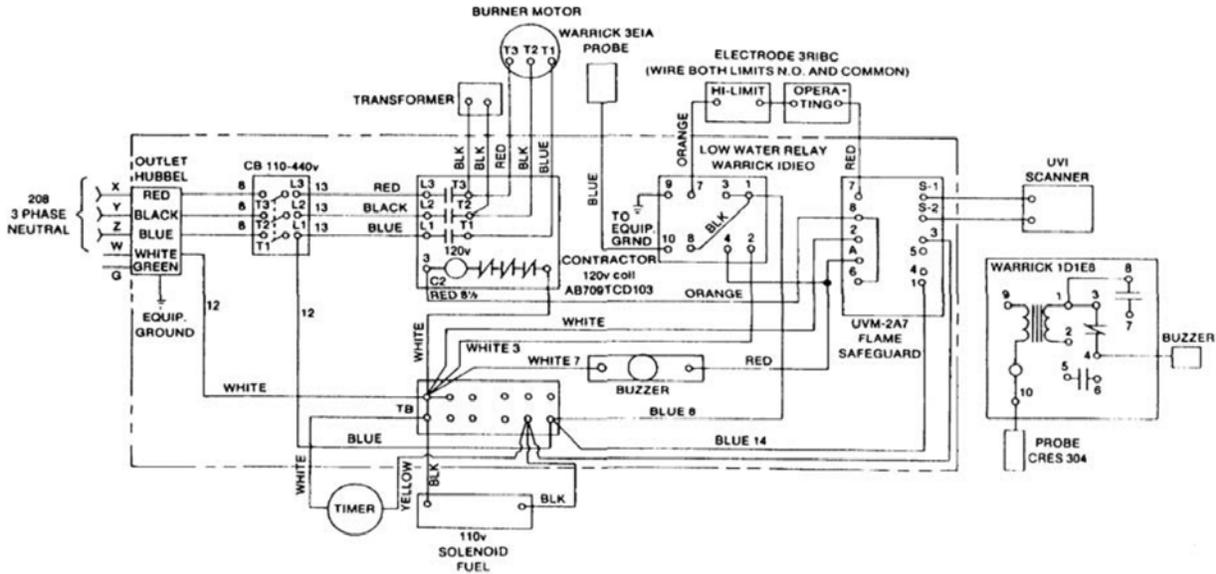

Wiring Diagram Decal for M-80 Water Heaters with 208 VAC transformer

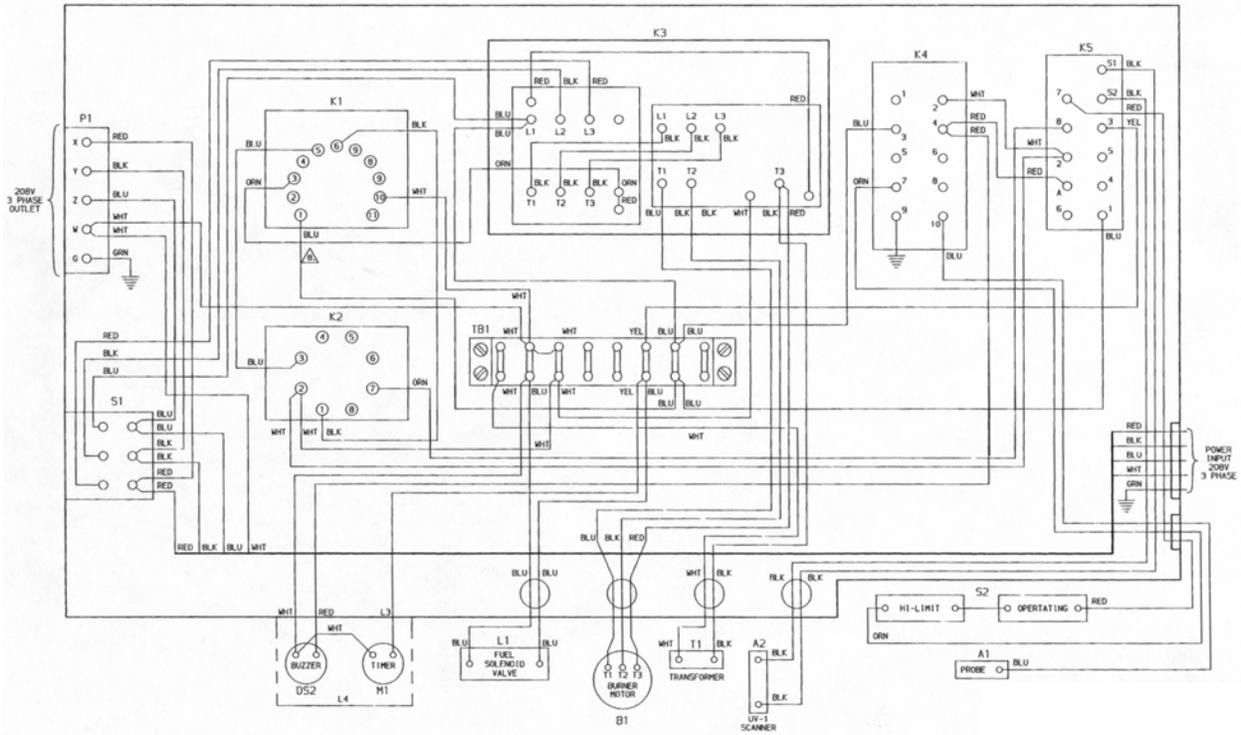

Wiring Diagram Decal Inside Control Box Cover for M-85 Water Heaters

**HEATER, WATER, LIQUID FUEL, M-80 AND M-85
OPERATION UNDER USUAL CONDITIONS**

INITIAL SETUP:**Tools**

Tool Kit, General Mechanic's (Item 3, WP 0038 00)

Personnel Required

Two

Materials/Parts

Tags, Marking (Item 13, WP 0057 00)

Equipment Condition

Water heater crated

SITING REQUIREMENTS

Read all warnings and cautions within this section and follow procedures outlined herein to ensure safe operation of the water heaters and associated equipment.



WARNING

The water heater weighs approximately 465 pounds. Lift and move the heater only with material handling equipment. Observe all safety precautions. Never stand under a water heater when it is being lifted. Failure to comply may result in serious injury or death to personnel.

This section outlines the siting requirements and provides procedures for the preparation and operation of the water heaters under usual conditions. Refer to work package 0006 00 for Operation Under Unusual Conditions.

There are no specific siting requirements for the water heaters used in conjunction with supported kitchen, bath, and laundry systems. Position the M-80 Water Heater as described in TM's for supported equipment. The M-85 Water Heater used with the M-85 series laundries is trailer mounted and positioned as described in TM 10-3510-222-10.

When used separately, in other applications, the water heater should be set upon firm and level ground. The method of water supply should be considered when positioning the heater. Freshwater supply hoses should not be subjected to vehicle traffic. Vehicle access for frequent refueling of diesel fuel may be required. Also consider the need for a 208 VAC power source to operate the water heater.

ASSEMBLY AND PREPARATION FOR USE

The water heater is shipped in a reusable crate. Use a forklift or other material handling equipment with an approved capacity of at least 1065 lbs (483 kg) to handle the crate. If lifting slings are used, arrange the slings carefully under the crate to ensure it will not tip. When using a forklift, slide the blades directly under the crate between the skid blocks

**WARNING**

Do not leave nails and other debris scattered around area. The nails and debris are sharp. Injuries to personnel could result.

Open the crate. Remove and retain shipping documents. Unpack components packaged and stored around the water vessel. These components can be lifted and removed from the packing skid by one or two persons. Check that all components of the end item are as listed in work package 0057 00 are included in the shipment. Visually inspect crate contents for damage sustained during shipment. Report damage on SF 364. Check all packaging material for loose parts before discarding. Retain shipping crate for reuse.

Remove all protective compounds and covering such as wax paper, waterproof tape, and barrier material. Using a dry cloth, remove all preservatives and grease from unpainted, threaded, or exposed surfaces.

ASSEMBLY AND INSTALLATION

If the water heater is used with a Bath Unit, Portable, Automated; Multi-Head Model PBU-100, or Model HEI-100, install and operate the water heater as described in TM 10-4510-206-14.

If the water heater is to be used with an M-85 series laundry, install and operate the water heater as described in TM 10-3510-222-10 and TM 10-3510-222-24, respectively.

When the water heater is used separately, in other applications, assemble it as follows:

CAUTION

To prevent equipment damage, ensure that hose couplings are free of dirt or foreign matter and that coupling gaskets are in place before connecting hoses.

1. Inspect freshwater Quick Disconnect (QD) hose coupling for cleanliness and presence of gasket.
2. If necessary, use needle nose pliers to remove a damaged gasket **(1)** from female QD coupling half **(2)**. Ensure entire gasket is removed, and the groove **(3)** is clear. Use needle-nose pliers to install a new gasket.

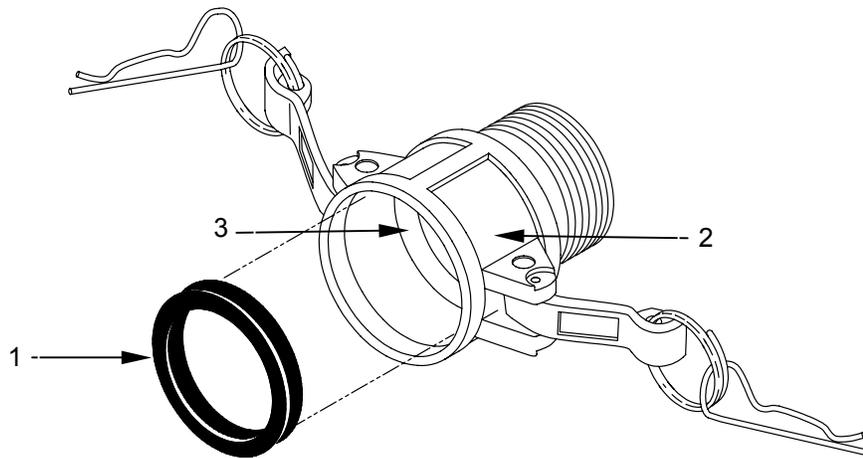

1. With water heater **(1)** positioned on level ground, connect QD coupling 1 ½" water hose **(2)** to water heater intake manifold **(3)**.
2. (M-80 only) Install exhaust stack elbow **(4)** on water heater with a slight turn to right to seat pin in slot.
3. (M-80 only) Insert guard assembly **(5)** and smoke stack **(6)** through bracket **(7)** onto elbow **(4)**.
4. (M-80 only) Tighten screw **(8)** on bracket **(7)** to secure smoke stack **(6)** and guard assembly **(5)**.



WARNING

Be sure that fuel lines do not touch, or cross water hoses, power cable, or exhaust duct. Melting/damage can occur causing leaking fuel and water or electrical hazards. Death by electrocution, fire, or explosion could result.

5. (M-85 only) Connect two 7-inch (178 mm) diameter exhaust ducts **(9)** together and connect to exhaust port **(10)**. Extend duct away from the water heater.
6. Connect hot water supply hose to the upper manifold **(11)**.



WARNING

Fuel used with the water heater is highly flammable and may cause severe burns or death if handled improperly.

7. Connect fuel supply line (12) to pump filter (13). Use a wrench to ensure connection is tight.
8. Connect fuel return line (14) to pump (15). Use a wrench to ensure connection is tight.
9. Connect power source to twist-lock receptacle (16) on control box.

CAUTION

Use only authorized fuels. Failure to do so may damage the equipment.

10. Ensure that fuel connected to the water heater is one of the following authorized types:

Diesel	VV-F-800 DF-A, DF-1, DF-2
Jet Fuel	MIL-T-5624 JP-4, JP-5
Jet Fuel	MIL-T-83133 JP-8
Fuel Oil	No.2 Commercial

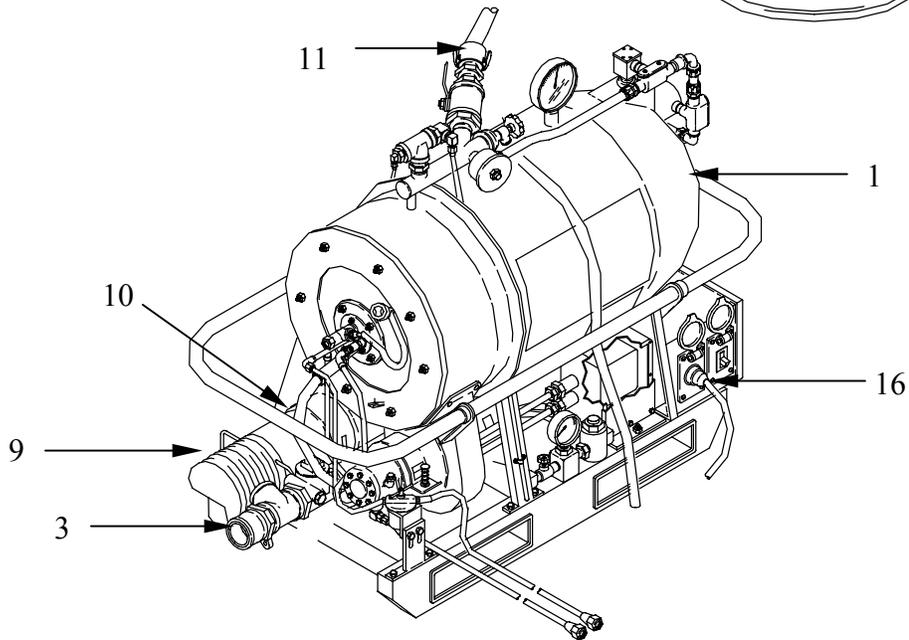
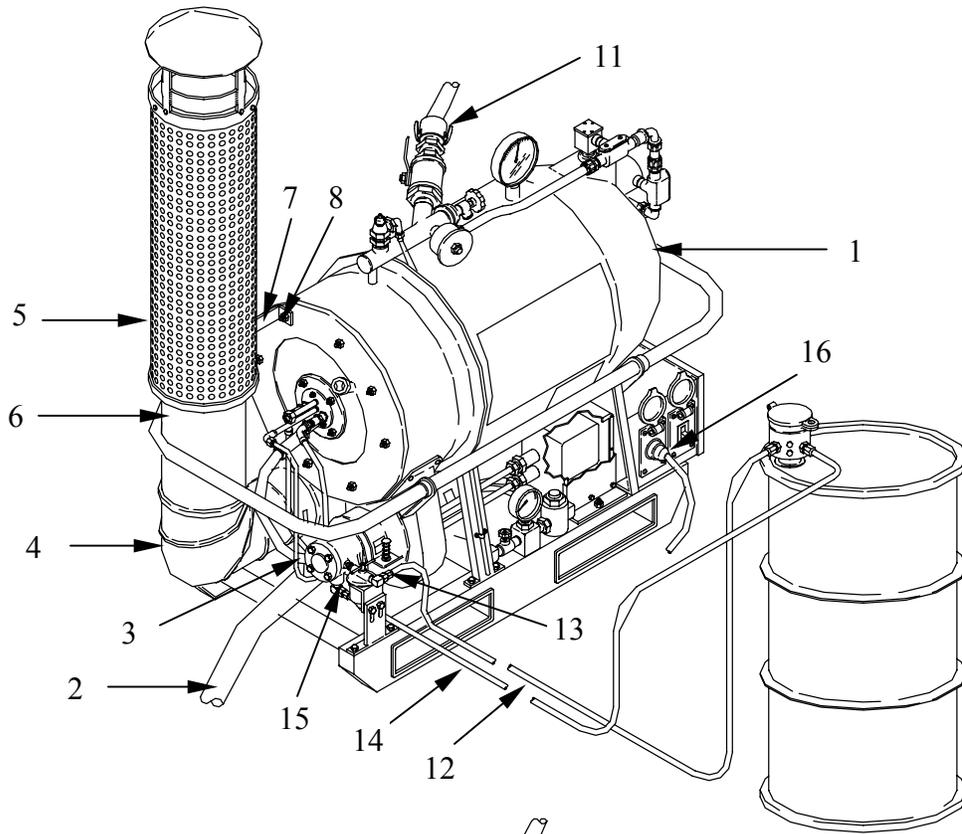

INITIAL ADJUSTMENTS

Before starting the water heater, perform the "Before Operation" PMCS as described in WP 0009 00. Then proceed as follows to make the initial adjustments:

1. Ensure power switch **(1)** is turned to OFF.
2. Ensure that manual fuel shut off valve **(2)** is closed.
3. Open blower air shutter **(3)** approximately half way.
4. Ensure that fuel supply hose **(4)** is connected to supply fitting **(5)** of fuel filter **(6)**, and return fuel line **(7)** to return fitting **(8)** of fuel pump **(9)**.
5. Open fuel pump primer plug **(10)** and fill fuel pump **(9)** with fuel. Replace plug.



WARNING

Exposed fuel and fuel vapor can ignite or explode resulting in possible serious injury or death. Observe proper safety precautions when servicing the fuel system.

CAUTION

Do not use fuel that is contaminated with water. Excessive water in the fuel supply will decrease heater efficiency and corrode both the chamber and the burner.

NOTE

The operator must periodically monitor the level of the fuel supply. The fuel container should be kept as full as possible to reduce water condensation. The frequency of refueling is dependent on the size of the fuel container.

6. Ensure that all water lines are connected.
7. Ensure that water heater drain cock **(11)** is closed.
8. Ensure the smoke pipe elbow **(12)**, cap and guard assembly **(13)** and two lengths of stove pipe **(14)** are securely installed on the M-80. Ensure the exhaust duct **(15)** is securely installed on the M-85.
9. Open vent valve **(16)**. Vent valve may be closed when discharging a steady stream of water.
10. Set water temperature control **(17)** to desired setting.

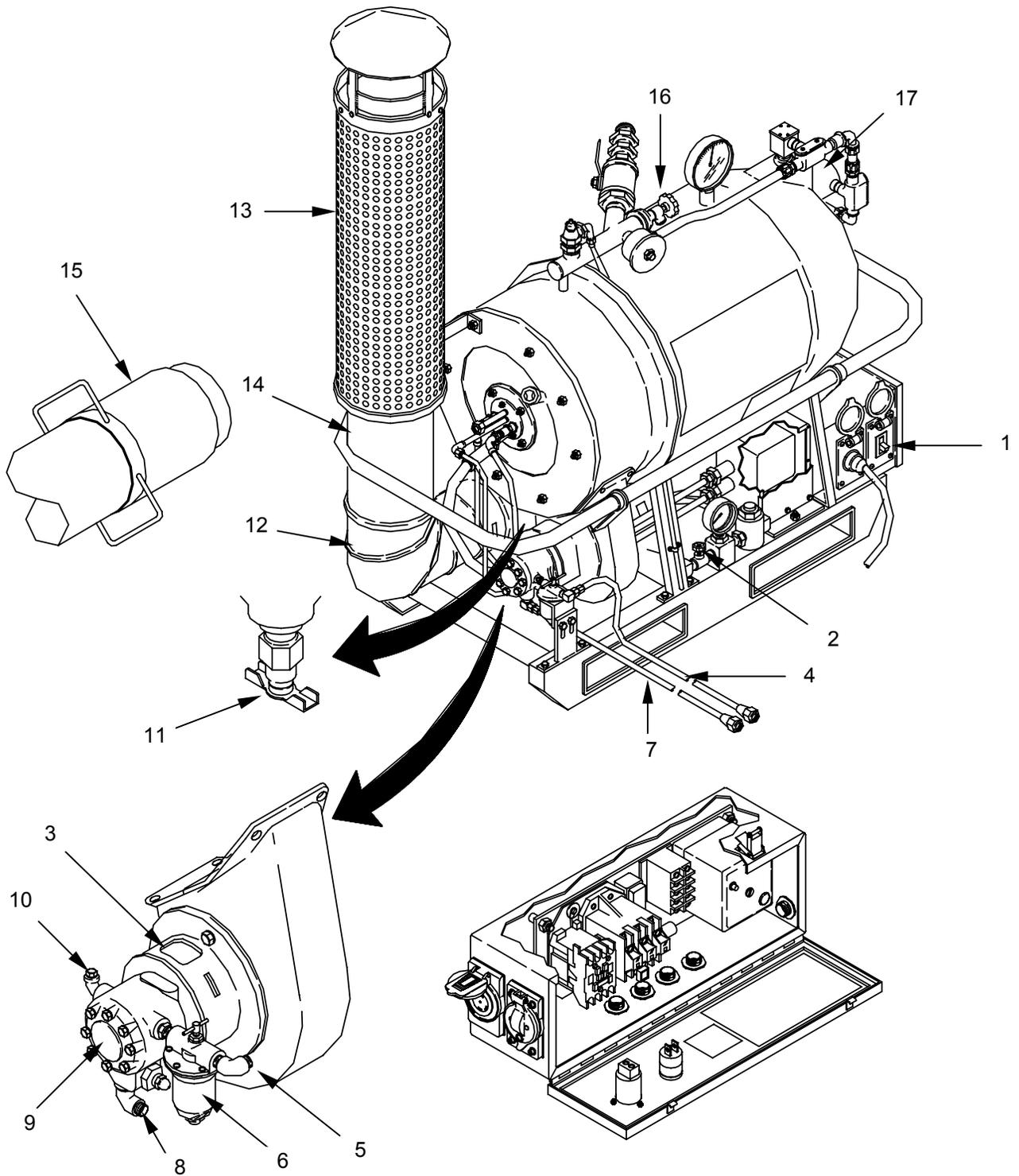

OPERATING PROCEDURES

1. Ensure that power source and water supply (water pump or commercial source) is on.

NOTE

Failure to bleed all air from the water heater will activate the low water switch, sounding the buzzer and preventing the unit from starting.

2. Bleed water heater by opening vent valve **(1)**. Close vent valve when completely bled.
3. Open fuel valve **(2)** and turn power switch ON **(3)**.
4. Combustion should occur within seven seconds. Observe through combustion chamber sight glass **(4)**.
5. If combustion fails to occur, water heater will automatically attempt to re-ignite. If combustion still does not occur, buzzer **(5)** sounds and water heater shuts down.
6. When buzzer sounds, press safety reset button **(6)**. If combustion still does not occur within two minutes, troubleshoot in accordance with Work Package 0015 00.
7. After start up, exhaust gasses from exhaust stack **(7)** should be transparent and smokeless. If smoke is present, slowly adjust air band **(8)** on blower assembly **(9)** until exhaust gasses are transparent and smokeless (see step 8. a. and b. below). The water heater is now in automatic operation.

NOTE

If operating at high altitudes, adjust the fuel pressure as necessary. Refer to WP 0022 00 for adjustment procedures.

8. If smoke is visible, adjust the airband on the air shutter assembly as follows:
 - a. Press the air band rivet **(10)**.
 - b. Move air band **(8)** downward to increase the air opening until smoke is no longer visible.

NOTE

Varying the air band position adjusts the ratio of air to fuel. Normal vibration of the water heater may change the air band position over time. Check the exhaust frequently for the presence of smoke.

9. Open the hot water output valve **(11)** when ready to deliver hot water. The valve handle is inline with the pipe when open.

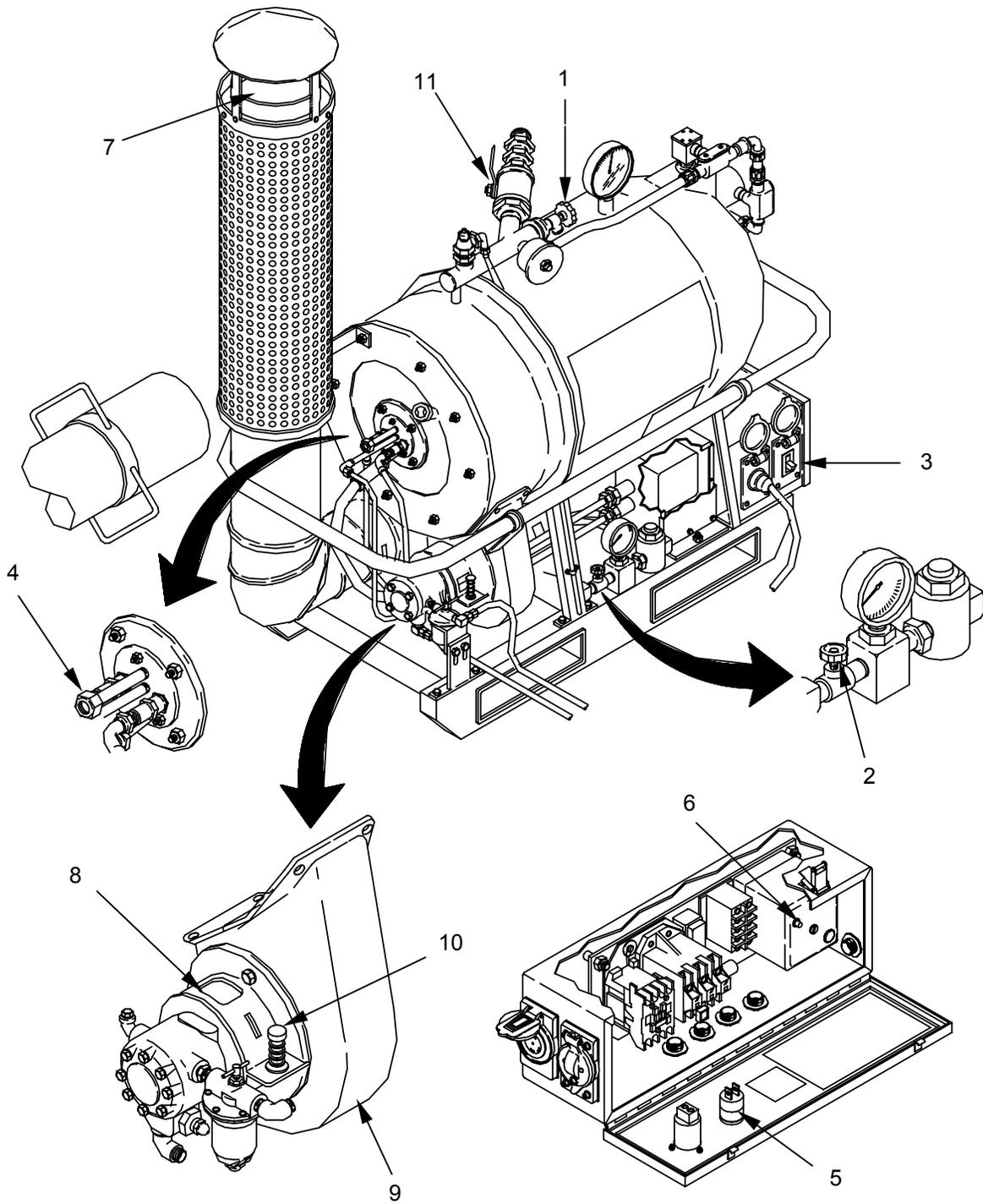

SHUTDOWN PROCEDURES

Perform the following shutdown procedures after normal use when temperature is 32⁰ F or above, and when the water heater will be used again within 5 days.

1. Turn **OFF** fuel valve **(1)**.
2. Turn **OFF** power switch **(2)**.

When the water heater is subjected to freezing temperatures (Below 32⁰ F), or when it is used for five days or more, continue as follows:

3. Remove fuel supply hose **(3)** from fuel drum adapter **(4)**.
4. Place end of fuel supply hose **(3)** into suitable container **(5)** and drain fuel from the hose.
5. Turn on power switch **(2)** and allow unit to operate until container **(5)** is almost empty. Turn off water heater fuel shut off valve **(1)** and let the heater operate until flame extinguishes.
6. Turn **OFF** power switch **(2)**.



WARNING

Ensure water heater has cooled down before touching any part that may still be hot.
Failure to comply may result in scalding or burning to skin.

7. Reach under water heater and open petcock **(6)** by turning counterclockwise to drain excess fuel from the combustion chamber.
8. Disconnect water hoses from the lower and upper manifold assemblies **(7)** and drain the hoses. The M-80 will drain when hoses are disconnected. To drain the M-85, open the vent valve **(8)**.

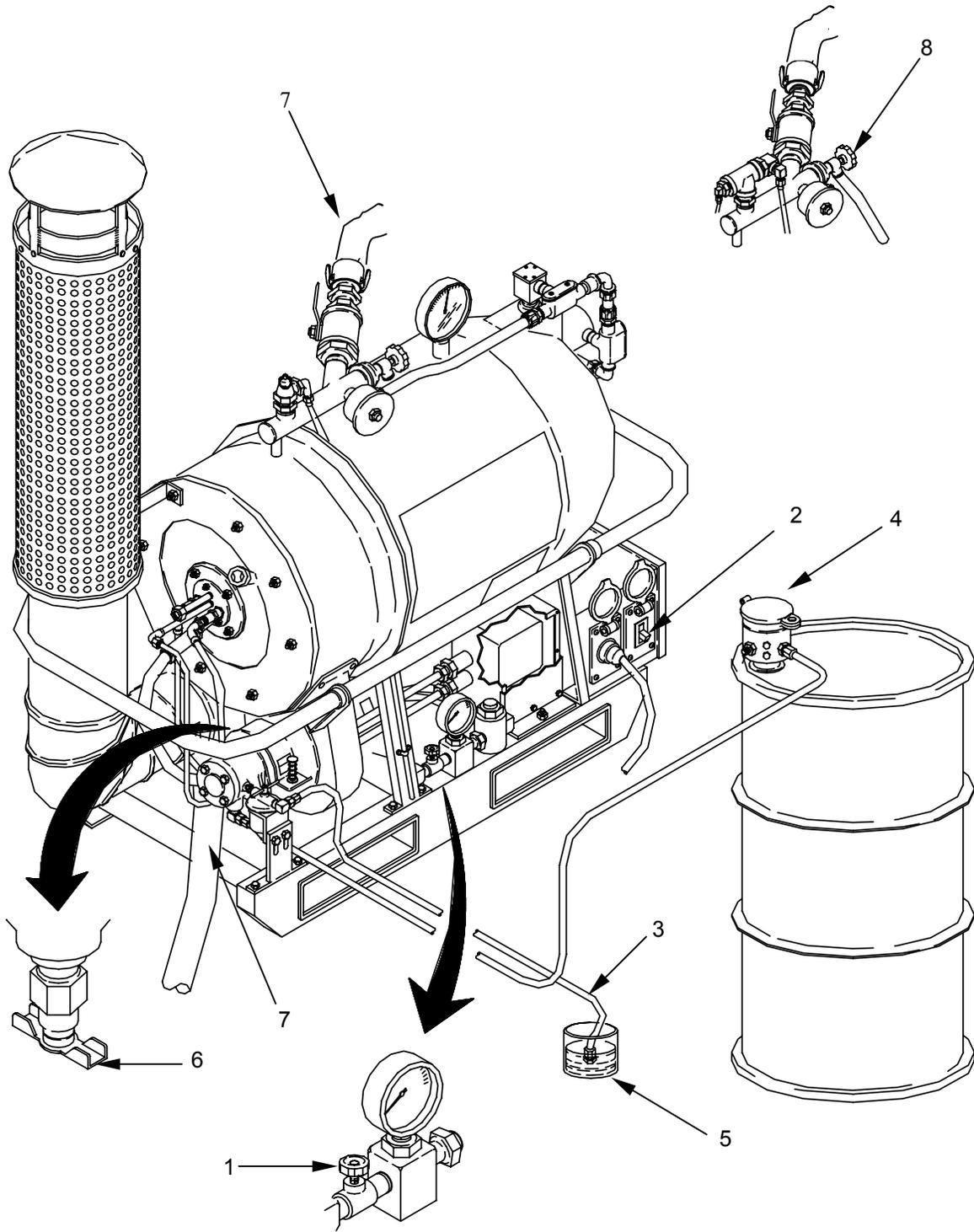

PREPARATION FOR MOVEMENT

To prepare the water heater for movement, proceed as follows:

1. Shut the water heater down as described under SHUTDOWN PROCEDURES in this work package.

**WARNING**

Ensure that power has been disconnected from the water heater control box assembly. Death or serious injury to personnel may result from electrocution. Ensure water heater has cooled down before attempting to prepare it for movement. This will avoid possible injuries to personnel from burns and scalding.

2. As time and circumstances allow, perform operator PMCS 'After' services as described in Work Package 0009 00.
3. Clean the water heater and associated equipment as described in Work Package 0009 00. Let equipment air dry, if possible.
4. Disconnect the smoke stack (M-80) or the exhaust duct (M-85) from the Water Heater.
5. Close air shutter on blower assembly.

**WARNING**

The water heater weighs approximately 465 lbs (1,065 lbs when crated). Lift and move the heater only with material handling equipment. Observe all safety precautions. Never stand under a water heater when it is being lifted.

NOTE

The M-85 Water Heater is normally installed on to the trailer bed of the M-85 Trailer Mounted Laundry and will require separate packing and crating only when being replaced.

6. After water heater and associated equipment has been cleaned, pack it in its original shipping crate. This will consist of:

Nomenclature	Quantity	Condition	Lift Requirements
Water Heater M-80 or M-85	1	Cleaned and dried	Material Handling Equipment
Smoke Stack Assembly (M-80)	1	Cleaned	1 Person
Burner Exhaust Ducts (M-85)	2	Cleaned	2 Persons each Duct
Fuel Hose, 12 Foot	2	Drained and coiled	1 Person
Drum Fill Adapter Assembly Type II	1	Cleaned	1 Person
TM 10-4520-259-13&P	1		

END OF WORK PACKAGE

**HEATER, WATER, LIQUID FUEL, M-80 AND M-85
OPERATION UNDER UNUSUAL CONDITIONS**

OPERATION IN UNUSUAL ENVIRONMENT/WEATHER CONDITIONS

General. Refer to Operation Under Usual Conditions (WP 0005 00), for specific operating instructions, and use this work package for further instruction if operating the water heater in unusual conditions. Read all sections that apply to the conditions to which the water heater will be exposed.

Unusual conditions include severe weather, such as 90 to 100 percent humidity for a week or more; 32 degree Fahrenheit (zero degree centigrade) or below temperatures for a week or more; 100 degree Fahrenheit (38 degree centigrade) or above temperatures for a week or more; blowing sand or dust; heavy rain or snow.

Operation in extreme heat (moist and dry) conditions. No specific requirements.

Operation in extreme cold conditions. When the water heater is not in operation, residual water in the heater will freeze when the temperature falls below 32^oF. It is therefore very important to drain the heater completely after shutdown and before the heater is left in temperatures below 32^oF.

Drain the water heater as described in work package 0005 00 under SHUTDOWN PROCEDURES.

Fill the fuel drum after operation to prevent formation and collection of moisture.

Cover the water heater with a tarpaulin or place it under cover, if possible, when it is to be left shutdown in temperatures below 32^oF.

Operation in rainy and/or humid conditions. No specific requirements.

Operation in extreme dry and dusty conditions. Locate the heater behind a windbreak. Try to protect the air shutter from contamination. Close the air shutter completely when shutting the heater down.

Operation in high altitude. Adjust the fuel pressure for elevation as described in Work Package 0022 00.

Nuclear, Biological, and Chemical (NBC) Decontamination. Perform interim decontamination procedures in accordance with FM 3-5 as the mission, resources, and tactical situation permit.



WARNING

For immediate decontamination procedures use ONLY hot soapy water for spot decontamination for hot surfaces of the M-80/M-85 heater and stack. Shut down and cool the heater for any additional decontamination procedures. DO NOT spray DS2 or any other combustible decontamination solutions or compounds on an operating heater or stack. DO NOT spray DS2 or any other combustible decontamination solutions or compounds on any equipment surfaces or components where the operating temperatures reach or exceed the flashpoint of DS2 (160^oFahrenheit or 71.1^oCelsius).

CHAPTER 3

OPERATOR TROUBLESHOOTING PROCEDURES
FOR
M-80 AND M-85 LIQUID FUEL WATER HEATER

**OPERATOR TROUBLESHOOTING PROCEDURES
HEATER, WATER, LIQUID FUEL, M-80 AND M-85
OPERATOR TROUBLESHOOTING INDEX**

TROUBLESHOOTING PROCEDURES

The Malfunction Index lists common malfunctions that may occur during water heater inspection and operation.

Find the malfunction the water heater is having in the index and go to the troubleshooting procedure provided within this work package.

These charts cannot list all malfunctions that may occur, all tests or inspections needed to find the fault, nor all actions required to correct the fault. If your malfunction is not listed in, or is not correctable enough through, this troubleshooting index, notify your supervisor or unit maintenance.

DO NOT START THE TASK UNTIL:

- You understand the task.
- You understand what you are to do.
- You understand what is needed to do the work.
- You have the things you need.

MALFUNCTION SYMPTOM INDEX

Malfunction or Symptom	Refer to Troubleshooting Procedure
Water heater fails to start	1
Fuel pressure pulsates	2
Fuel pressure too high or too low	3
Fuel pump fails to deliver fuel to burner	4
Flame fails in burner	5
Black smoke exits from burner exhaust duct	6



WARNING

The water heater operates on 208 VAC power. Ensure that the power cable is undamaged, does not lie in water, and is properly connected. Failure to comply may cause serious injury or death to personnel from electrical shock.

Table 1. Water Heater Troubleshooting Procedures.

MALFUNCTION	TEST OR INSPECTION	CORRECTIVE ACTION
1. Water Heater Fails to Start.	Step 1. Check that 208 V 3-ph electrical power is available and correctly connected to the water heater. Check power connections to the water heater.	If not correctly connected, check power source and cables.
	Step 2. Check load limit switch, if water heater has one, to see if it is tripped.	If tripped, reset load limit switch.
	Step 3. Check reset button on blower motor if water heater does not have a load limit switch.	Reset blower motor.
	Step 4. Check water supply in water heater tank.	Fill tank with water if not full. Bleed all air from system.
	Step 5. Check flame safeguard control switch.	Reset flame safeguard control switch.
	Step 6. Check blower motor overload switch.	Reset blower motor overload switch.
	Step 7. Check motor contactor in control box.	If tripped, reset contactor.
	Step 8. Check that water temperature thermostat is set high enough to start the heater.	Increase thermostat setting.
		If condition persists, notify direct support maintenance.
2. Fuel pressure pulsates.	Step 1. Check fuel feed hose connections for leaks.	Tighten fuel hose connections.
	Step 2. Check for clogged fuel filter.	If clogged, drain, and clean.
	Step 3. Inspect strainer cover for loose hardware.	Tighten cover screws.
	Step 4. Inspect fuel hoses for ruptures and leaks.	Replace hoses.
	Step 5. Check coupling between motor and fuel pump for slippage.	Tighten coupling or replace.
		If condition persists, notify direct support maintenance.



WARNING

Fuel is very flammable and can explode easily. To avoid serious injury or death, keep fuel away from open fire. Do not work on fuel system when burner is hot. Fuel can be ignited by hot burner. Shut off motor and do not smoke when working on fuel system.

Table 1. Water Heater Troubleshooting Procedures (continued).

3. Fuel pressure too high or too low.	Step 1. Check burner fuel control valve.	Ensure valve is fully open.
	Step 2. Check hoses and make certain they are not clogged or kinked,	Remove kinks and/or replace clogged hoses.
	Step 3. Check for clogged fuel filter and/or strainer.	If clogged, drain and clean.
		If condition persists, notify direct support maintenance.
4. Fuel pump fails to deliver fuel to burner.	Step 1. Check fuel supply in fuel drum.	Fill drum with fuel.
	Step 2. Check both ends of fuel hoses for air leaks.	Tighten hose connections.
	Step 3. Check supply and return hose assemblies to see if they are reversed.	Disconnect and reconnect hose supply.
	Step 4. Check fuel pump to verify it has been primed.	Prime fuel pump as in WP 0005 00.
	Step 5. Check coupling between motor and fuel pump for slippage.	If loose, notify supervisor.
	Step 6. Check for clogged fuel filter and/or strainer.	If clogged, drain and clean.
		If condition persists, notify direct support maintenance.



WARNING

Fuel is very flammable and can explode easily. To avoid serious injury or death, keep fuel away from open fire. Do not work on fuel system when burner is hot. Fuel can be ignited by hot burner. Shut off motor and do not smoke when working on fuel system.

Table 1. Water Heater Troubleshooting Procedures (continued).

MALFUNCTION	TEST OR INSPECTION	CORRECTIVE ACTION
5. Flame fails in burner.	Step 1. Check fuel supply in fuel drum.	If insufficient, fill fuel drum.
	Step 2. Inspect fuel hose connections for leaks.	Tighten fuel hose connections.
	Step 3. Check fuel hose for clogs.	Disconnect fuel hose and clear all foreign matter clogging the line.
	Step 4. Check supply and return fuel hose assemblies to see if they are reversed.	If reversed, disconnect and reconnect fuel hose assemblies correctly.
	Step 5. Check fuel pump to verify that it has been primed.	Prime fuel pump as described in WP 0005 00.
	Step 6. Check ignition cable assemblies for loose connections at spark plug and transformer end.	Tighten any loose connections.
		If condition persists, notify direct support maintenance.
6. Black smoke exits from burner exhaust duct.	Step 1. Check to see if fuel-to-air ratio adjustment is correct as described in WP 0005 00.	Adjust shutter for proper volume of air intake.
		If condition persists, notify direct support maintenance.

END OF WORK PACKAGE

CHAPTER 4

**OPERATOR MAINTENANCE INSTRUCTIONS
FOR
M-80 AND M-85 LIQUID FUEL WATER HEATER**

**HEATER, WATER, LIQUID FUEL M-80 AND M85
SERVICE UPON RECEIPT**

SERVICE UPON RECEIPT

No specific de-processing is required for any of the water heater components before they are used. However, the tasks prescribed in this work package must be performed to ensure proper functioning of this equipment.

GENERAL

The M-80 and M-85 Water Heater is shipped crated on a pallet and will include the components specified in the Components of End Item and Basic Issue Items Lists (work package 0057 00).

The following tasks must be performed upon receipt of the M-80 and M-85:



WARNING

The water heater is heavy. To avoid injuries, six persons are required to uncrate the heater and move it into position.

Unpacking. Uncrate the heater and save the wood pallet on which it was shipped.

Packing list verification. Check the components removed against the packing list to see if the shipment is complete. Report all discrepancies in accordance with DA Pam 750-8.

Inspection. Inspect the heater and its components for damage incurred during shipment. If the equipment has been damaged in shipment, report the damage on SF 364, Report of Discrepancy. In addition, a unit maintenance technician should inspect the equipment, using the PMCS inspection procedures in work package 0009 00 and note discrepancies on DA Form 2404.

Verification of equipment modifications. Check to see if any of the equipment has been modified in any way. Notify your supervisor or unit maintenance personnel if modifications are noted.

Depreservation. Remove preservative materials and compounds applied to the heater to protect it during storage and shipment. Clean the heater as described in work package 0009 00. Perform 'Before' PMCS service as described in work package 0009 00 prior to placing the heater in operation.

M-85 Model Installation. To remove/install the M-85 Model water heater on the M-85 Trailer Mounted Laundry Unit, follow procedures in TM 10-3510-222-24.

END OF WORK PACKAGE

OPERATOR MAINTENANCE
HEATER, WATER, LIQUID FUEL, M-80 AND M-85
NSN 4520-01-162-0385 (M-80) 4520-01-237-3719 (M-85)
PREVENTIVE MAINTENANCE CHECKS AND SERVICES (PMCS), INTRODUCTION

INTRODUCTION

Preventive Maintenance Checks and Services (PMCS) are performed to keep the Heater, Water, Liquid Fuel in good operating condition and ready for its primary mission. The checks are used to find, correct, and report problems. PMCS is performed every day the Heater, Water, Liquid Fuel is in operation, and is done according to the PMCS table provided. Pay attention to **WARNING**, **CAUTION**, and **NOTE** statements. A **WARNING** indicates that someone could be hurt or killed. A **CAUTION** indicates that equipment could be damaged. A **NOTE** may make your maintenance or repair task easier.

Be sure to perform scheduled PMCS. Always perform PMCS in the same order so it becomes habit. With practice, you will quickly recognize problems with the equipment.

Use DA Form 2404, Equipment Inspection and Maintenance Worksheet, to record any discovered faults. Do not record faults that you fix!

PMCS PROCEDURES

Table 1 lists inspections and care required to keep your equipment in good operating condition. It is arranged so that you can perform before operation checks as you walk around the equipment.

Explanation of Table 1 columns**Item Number**

Indicates the reference number. When completing DA Form 2404, Equipment Inspection and Maintenance Worksheet, include the item number for the item to check/service indicating a fault. Item numbers appear in the order you must perform the checks/services listed.

Interval

Indicates when you must perform the procedure in the procedure column.

- before** - perform before equipment operation
- during** - perform during equipment operation
- after** - perform after equipment has been operated
- weekly** - perform every week
- monthly** - perform each month
- hours** - perform at the noted hourly interval

Item to Check/Service

Indicates the item to be checked or serviced.

Procedure

Indicates the procedure you must perform on the item listed in Item to Check/Service column. You must perform the procedure at the time specified in the Interval column.

Not Fully Mission Capable If:

Indicates faults which will prevent your equipment from performing its primary mission. If you perform procedures listed in Procedure column which show faults listed in this column, do not operate the equipment. Follow standard procedures for maintaining the equipment or reporting equipment failure.

Other special entries

Observe all special information and notes that appear in Table 1.

When a check/service procedure is required for both weekly and before intervals, it is not necessary to perform the procedure twice if the equipment is operated during the weekly period.

COMMON CHECKS AND CLEANING

Cleaning

Always keep the equipment clean. Remove dirt, sand, and debris from all circuit breakers and hose connections.

Bolts, nuts, and screws

Check them for obvious looseness, missing, bent, or broken condition on equipment. If you find a bolt, nut, or screw you think is loose, tighten it or report it to your supervisor.

Hoses

Look for wear, damage, and leaks. Ensure clamps are tight. Wet spots show leaks, but a stain around a fitting or connector can also mean a leak. If a leak comes from a loose fitting or coupling, tighten it. If something is broken or worn out, report it to your supervisor.

LEAKAGE DEFINITION FOR PERFORMING PMCS

It is necessary for you to know how fluid leakage affects the status of the equipment. The following are the types/classes of leakage an operator needs to know to be able to determine the status of the water system. Learn these leakage definitions and remember - when in doubt, notify your supervisor.

CAUTION

Equipment operation is allowable with minor leakages (Class I or II). Of course, consideration must be given to fluid capacity in the system, when in doubt, notify your supervisor.

When operating with Class I or II leaks, continue to check fluid levels as required in your PMCS.

Class III leaks should be reported immediately to your supervisor.

Class I - Seepage of fluid (as indicated by wetness or discoloration) not great enough to form drops.

Class II - Leakage of fluid great enough to form drops but not enough to cause drops to drip from item being checked/inspected.

Class III - Leakage of fluid great enough to form drops that fall from items being checked/inspected.

**HEATER, WATER, LIQUID FUEL, M-80 AND M-85
LUBRICATION REQUIREMENTS**

LUBRICATION REQUIREMENTS

There are no lubrication requirements for the M-80 and M-85 Water Heaters.

HEATER, WATER, LIQUID FUEL, M-80 AND M-85
 NSN 4520-01-162-0385 (M-80) 4520-01-237-3719 (M-85)
 PREVENTIVE MAINTENANCE CHECKS AND SERVICES (PMCS)

INITIAL SETUP:**Tools****Personnel Required**

One

Materials/Parts

Cloth, Cleaning (Item 1, WP 0059 00)

Equipment Condition

Water heater set up but not in operation.

INTRODUCTION

Preventive Maintenance Checks and Services (PMCS) keep the water heater and its associated equipment in good operating condition. These checks are used to find, correct, or report problems. Operator personnel are to do the PMCS jobs as shown in the PMCS table. PMCS are done every day the water heater is operated, using the PMCS table. Pay attention to WARNING and CAUTION statements. A WARNING means someone could be hurt. A CAUTION means equipment could be damaged.

Before you begin using the M-80 / M-85, do **Before PMCS**

During use of the M-80 / M-85, do **During PMCS**

After using the M-80 / M-85, do **After PMCS**

Once a week, do **Weekly PMCS** if the M-80 / M-85 has been in use

Do **Monthly PMCS** once a month if the M-80 / M-85 has been in use

If you find something wrong when performing PMCS, fix it using troubleshooting and/or maintenance procedures.

The right-hand column of the PMCS table lists conditions that make the water heater not fully mission capable. Write up the faults that cannot be repaired on DA Form 2404 for unit maintenance. For further information on how to use this form, see DA PAM 750-8.

If tools that are required to perform PMCS are not listed in procedures, notify your supervisor.

INSPECTION

Look for signs of trouble. Senses help here. You can feel, smell, hear, or see many problems that can be eliminated before they get worse. Inspect to see if items are in good condition. Are components correctly installed and secured? Is any damage to the frame or components visible? Correct any faults or notify unit maintenance. There are some common items to check on the water heater. These include:

- Signs of physical damage to any part of the heater
- Proper operation and condition controls and indicators
- Missing or loose parts such as the exhaust stack or duct
- Signs of fuel leaks from the heater or drum adapter components



WARNING

The water heater operates on 208 VAC power. Ensure that the power cable is undamaged, does not lie in water, and is properly connected. Serious injury or death can result from electrical shock.

LUBRICATION SERVICE INTERVALS

There are no lubrication requirements.

CLEANING

Proper cleaning of the water heater and components is an integral part of maintenance. It will help prevent possible problems in the future, so make it a habit to clean the water heater and its components whenever necessary. The preferred method is to use a brush with a mild soap solution and rinsing with low-pressure fresh water. Keep water away from electrical parts or cover with plastic before cleaning. After cleaning, allow the water heater to air dry. When cleaning rusty areas on metal parts, use the dry cleaning agent listed in Work Package 0057 00, Expendable and Durable Item's List.



WARNING

DO NOT use diesel fuel or gasoline for cleaning. These fluids are highly flammable. Death or serious injury to personnel can result.

DO NOT SMOKE when using P-D-680B Dry Cleaning Solvent. NEVER USE IT NEAR AN OPEN FLAME. Be sure there is a chemical fire extinguisher nearby and use cleaning solvent only in well ventilated places. The flash point of solvent is 200°F (93°C).

USE CAUTION when using the cleaning solvent. Cleaning solvents can irritate exposed skin after prolonged contact. In cold weather, contact of exposed skin with cleaning solvents can cause frostbite. Wear protective clothing including eyewear and gloves.

CAUTION

When cleaning the water heater, it must be COLD (same temperature as outside air). DO NOT point water or steam directly at any electrical connection. DO NOT point water or steam directly at any electrical connection. DO NOT use high-pressure water supply system. Failure to comply may cause damage to the electrical system or other components.

Keep cleaning solvents, gasoline and lubricants away from both rubber and plastic parts. These agents will deteriorate plastic material.

LEAKAGE CRITERIA

It is necessary for you to understand how leaking fluids affects the status of the water heater. The following are types/classes of leakage you need to know to determine the status of the water heater. Learn these leakage definitions and remember - when in doubt, notify your supervisor.

CAUTION

Water heater operation is allowed with minor leakages (Class I or II). Consideration must be given to fluid capacity on the item or system being inspected. When in doubt, notify your supervisor.

When operating with Class I, or II leaks, continue to check fluid levels as required in the PMCS. Class III leaks should be reported immediately to your supervisor.

Class I — Not enough seeping fluid (indicated by wetness or discoloration) to form drops

Class II — Great amount of leaking fluid to form drops, but not enough to cause drops to drip from item being checked/inspected

Class III — Great amount of leaking fluid to form drops that fall from item being checked/inspected

THIS SECTION COVERS:

Before Operation PMCS Checks and Services

INITIAL SETUP:

Tools

Tool Set, General Mechanic's, Automotive (Item 3, WP 0038 00)

Personnel Required

One

Materials/Parts

Equipment Condition

Water heater set up for operation.

Table 1. Preventive Maintenance Checks and Services for M-80 and M-85 Water Heater.

ITEM NO.	INTERVAL	ITEM TO BE CHECKED OR SERVICED	PROCEDURES	EQUIPMENT NOT READY/ AVAILABLE IF:
1	Before	Water Heater	Inspect the water heater for general signs of physical damage.	Water heater is damaged.
2	Before	Fuel Shutoff Valve	<p>Check the fuel shutoff valve (1). Determine that it moves freely and doesn't bind or catch. Check for bent valve stem (2).</p> 	<p>Fuel shutoff valve binding or catching and does not open and close freely. Valve stem is bent.</p>
3	Before	Ignition Cables	<p>Check condition of ignition cables (3). Determine if the cables are loose or frayed.</p> 	Cables are frayed or loose.

Table 1. Preventive Maintenance Checks and Services for M-80 / M-85 – continued.

ITEM NO.	INTERVAL	ITEM TO BE CHECKED OR SERVICED	PROCEDURE	EQUIPMENT NOT READY/ AVAILABLE IF:
4	Before	Vent Valve	Check the vent valve (4) and determine that it moves freely and does not bind or catch. Check for bent valve stem (5).	Inoperative vent valve.
5	Before	Combustion Chamber Sight Glass	Check the combustion chamber sight glass (6). Determine if the glass is undamaged and assembly is securely installed.	Sight glass missing. Assembly not correctly installed or loose or damaged.

Table 1. Preventive Maintenance Checks and Services for M-80 / M-85 – continued.

ITEM NO.	INTERVAL	ITEM TO BE CHECKED OR SERVICED	PROCEDURE	EQUIPMENT NOT READY/ AVAILABLE IF:
6	Before	Burner Assembly Sight Glass	Check the combustion chamber sight glass (7). Determine if the glass is undamaged and assembly is securely installed.	Sight glass missing. Assembly not correctly installed or loose or damaged.
<div style="display: flex; justify-content: space-around; align-items: center;"> <div style="text-align: center;">  <p>M-80</p> </div> <div style="text-align: center;">  <p>M-85</p> </div> </div>				
7	Before	Smoke Stack and Guard Assembly (M-80)	Check the serviceability of the smoke stack (8) and guard (9) assembly. Parts should fit tightly and have no dents. Check for excessive rust.	Parts are dented and do not fit together well. There is excessive rust on these parts preventing a proper fit.
<div style="display: flex; justify-content: space-around; align-items: center;"> <div style="text-align: center;">  <p>9</p> </div> <div style="text-align: center;">  <p>8</p> </div> </div>				

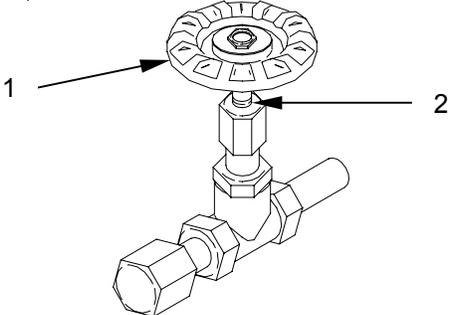
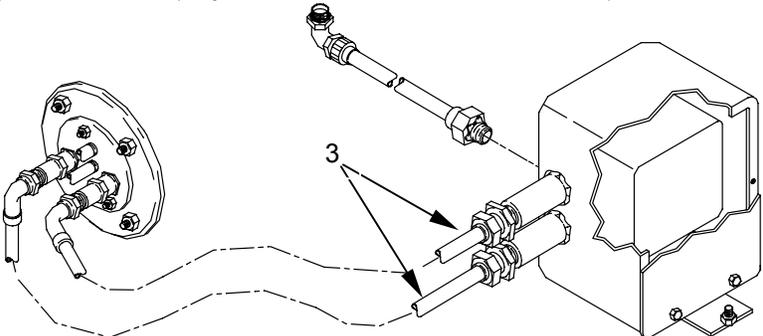
Table 1. Preventive Maintenance Checks and Services for M-80 / M-85 – continued.

ITEM NO.	INTERVAL	ITEM TO BE CHECKED OR SERVICED	PROCEDURE	EQUIPMENT NOT READY/ AVAILABLE IF:
8	Before	Exhaust Duct (M-85)	Check the serviceability of the exhaust duct assembly (10). Parts should fit tightly and have no dents.	Ducts are dented and do not fit together well.
9	During	Fuel Pressure Gage	Check gage (11) to verify that it reads 75 to 80 PSI on the M-80 or 100 to 105 PSI on the M-85. Check for broken glass or stained dial.	Gage is not in proper range. Glass is broken and dial stained.



The diagram shows a flexible exhaust duct assembly with two metal clamps at the ends. An arrow labeled '10' points to the middle section of the duct.

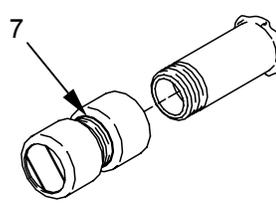
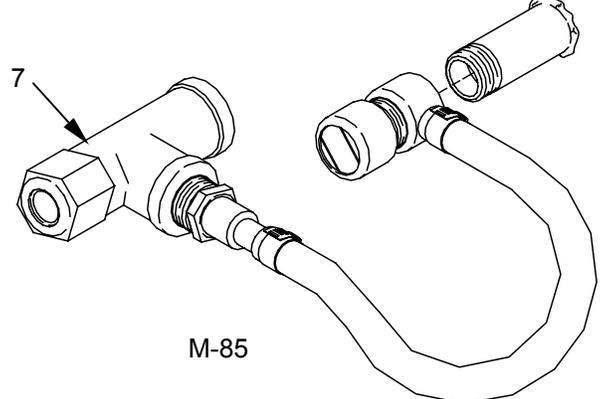
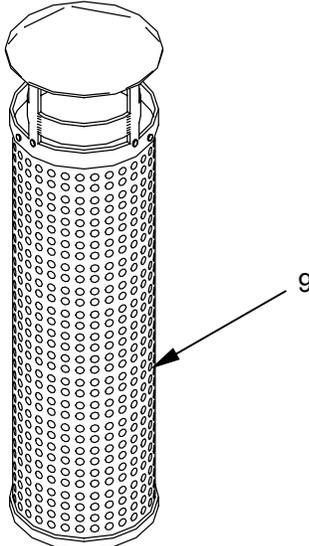
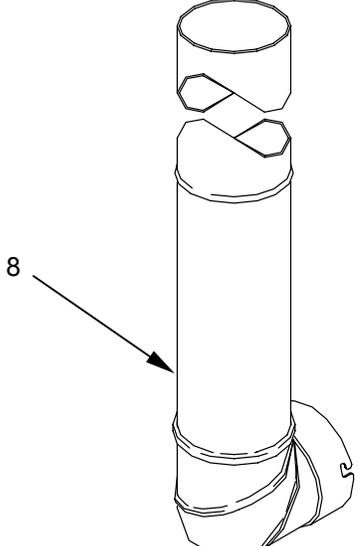
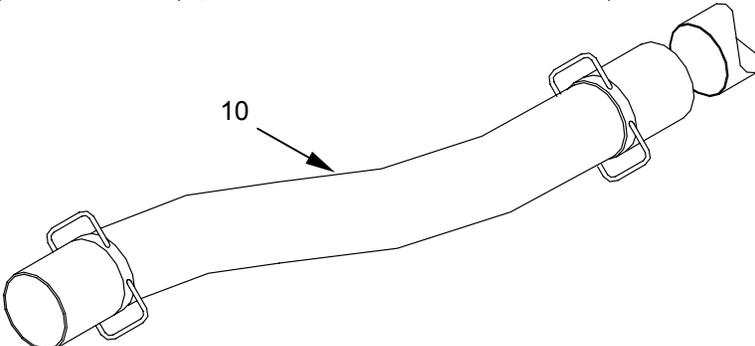
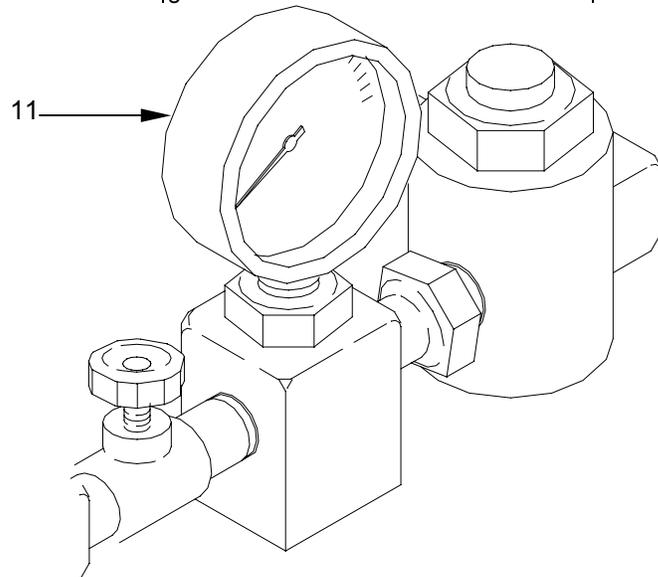

The diagram shows a fuel pressure gage with a circular dial and a needle, mounted on a rectangular metal base. An arrow labeled '11' points to the dial. To the right of the gage is a cylindrical component with a hexagonal top.

Table 1. Preventive Maintenance Checks and Services for M-80 / M-85 – continued.

ITEM NO.	INTERVAL	ITEM TO BE CHECKED OR SERVICED	PROCEDURE	EQUIPMENT NOT READY/ AVAILABLE IF:
10	During	Fuel Supply Assembly and Drum Adapter	Check the fuel pump (12), fuel lines (13), fuel filter (14), and drum fill adapter (15) for leaks, loose connections and damage.	Fuel leaks, loose connections or damage to fuel supply system.
				
11	During	Air Shutter Assembly	Check exhaust gases and, if necessary, adjust the air shutter (16) until the exhaust emission is clear. Check the shutter for correct operation. The pin (17) and shutter should operate smoothly and not bind or stick.	Pin or shutter does not move freely or cannot be adjusted.
				

Table 1. Preventive Maintenance Checks and Services for M-80 / M-85 – continued.

ITEM NO.	INTERVAL	ITEM TO BE CHECKED OR SERVICED	PROCEDURE	EQUIPMENT NOT READY/ AVAILABLE IF:
12	Quarterly	Burner Head Assembly	Check the burner head assembly (18) for rust, corrosion or damage. Check burner nozzle (19) and spark plugs (20) for carbon buildup. Check gap as described in Work Package 0018 00.	Assembly rusty or corroded. Heavy carbon buildup on spark plugs. Incorrect gap.

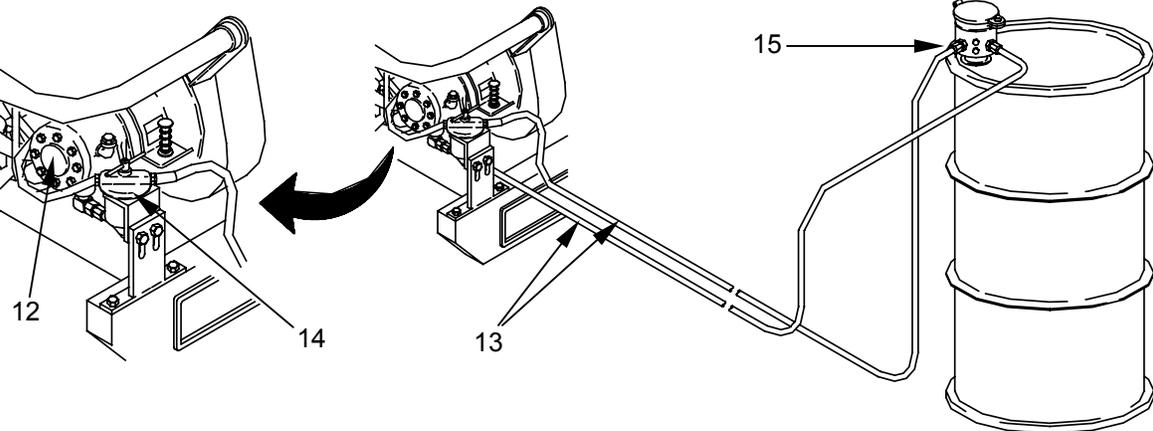
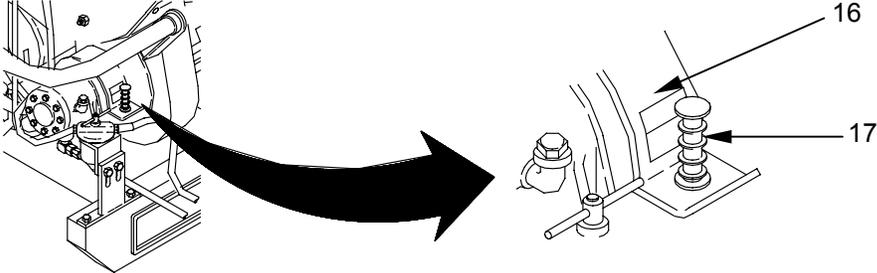
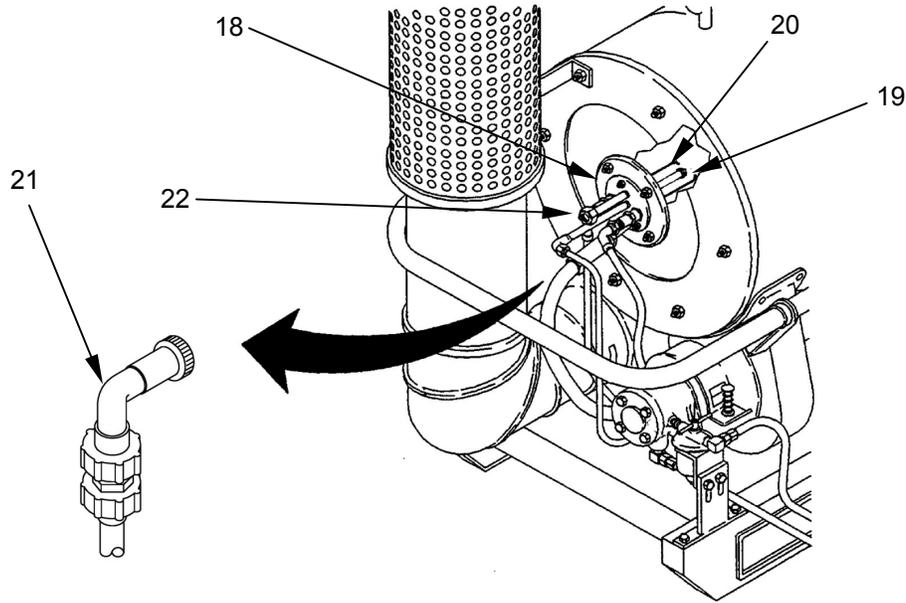

Table 1. Preventive Maintenance Checks and Services for M-80 / M-85 – continued.

ITEM NO.	INTERVAL	ITEM TO BE CHECKED OR SERVICED	PROCEDURE	EQUIPMENT NOT READY/ AVAILABLE IF:
13	Quarterly	Scanner and Burner Assembly Sight Glass	Check the scanner assembly (21) for security of mounting. Check burner assembly sight glass (22) for security of mounting. Check for damage to sight glass.	Scanner assembly loose. Burner sight glass assembly loose or glass broken/damaged.

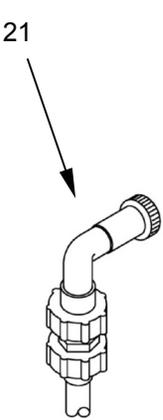
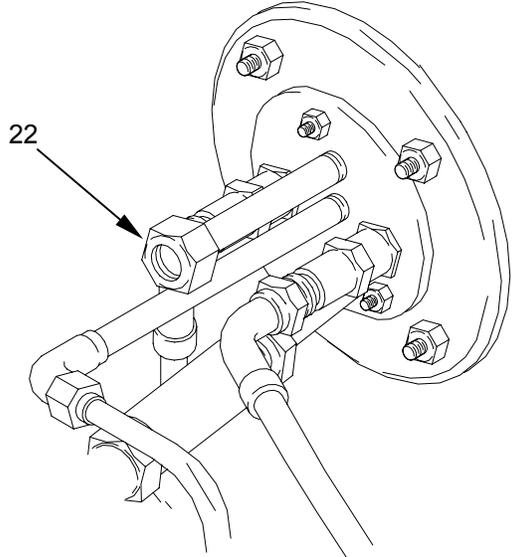



Table 1. Preventive Maintenance Checks and Services for M-80 / M-85 – continued.

ITEM NO.	INTERVAL	ITEM TO BE CHECKED OR SERVICED	PROCEDURE	EQUIPMENT NOT READY/ AVAILABLE IF:
14	Quarterly	Fuel Pump Assembly	Check assembly (23) for leaks and damage. Service pump assembly by replacing or cleaning the fuel pump strainer (24) and fuel filter (25) .	Pump assembly is damaged or leaking. Filter or strainer clogged.

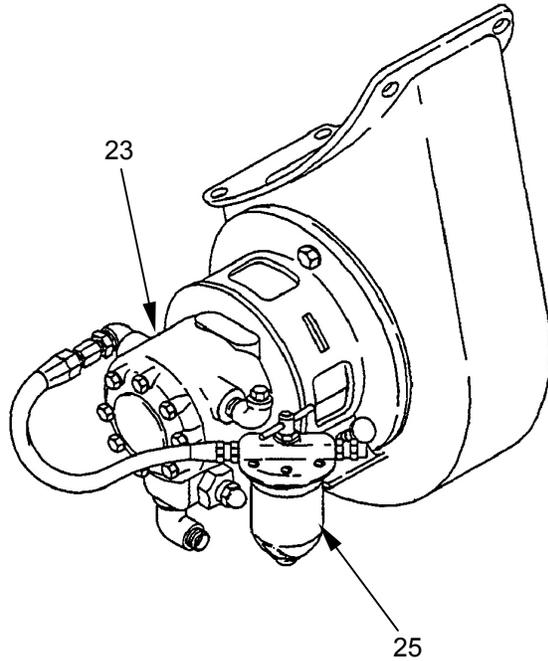
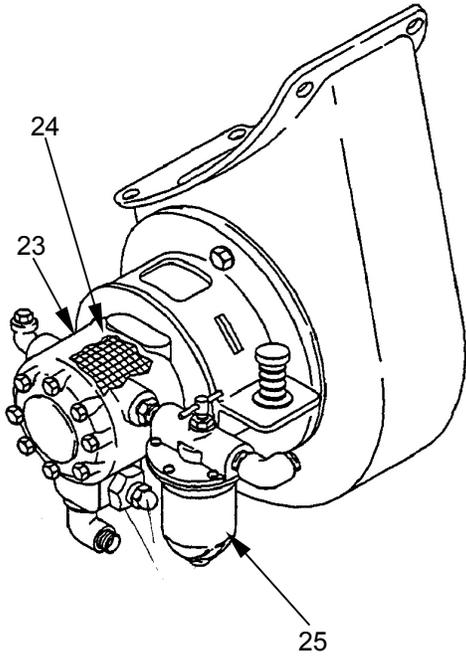

Table 1. Preventive Maintenance Checks and Services for M-80 / M-85 – continued.

ITEM NO.	INTERVAL	ITEM TO BE CHECKED OR SERVICED	PROCEDURE	EQUIPMENT NOT READY/ AVAILABLE IF:
15	Quarterly	Blower Motor Assembly	Check blower motor assembly (26) for secure mounting. Check the air band rivet (27) for weakness.	Motor assembly loose. Air band rivet inoperative.

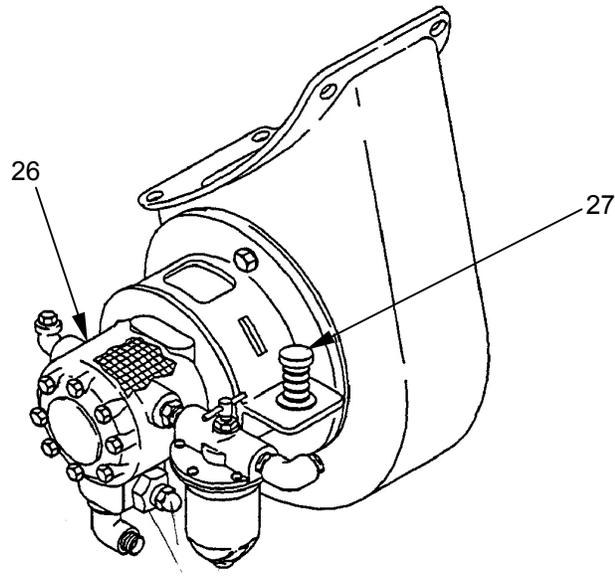

Table 1. Preventive Maintenance Checks and Services for M-80 / M-85 – continued.

ITEM NO.	INTERVAL	ITEM TO BE CHECKED OR SERVICED	PROCEDURE	EQUIPMENT NOT READY/ AVAILABLE IF:
16	Quarterly	Manifold Assemblies	Check the upper (28) and lower (29) manifold assemblies for rust, corrosion, or damaged, inoperative relieve valves (30).	Rusted, corroded, or damaged manifold assemblies. Inoperative relieve valve(s).

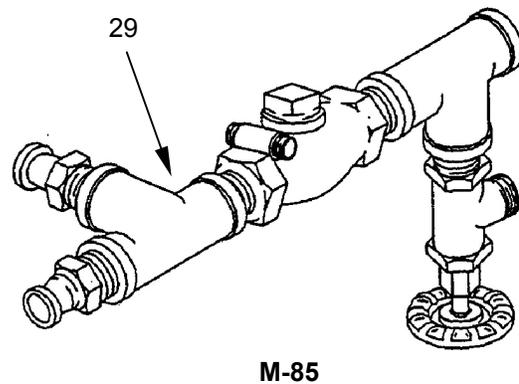
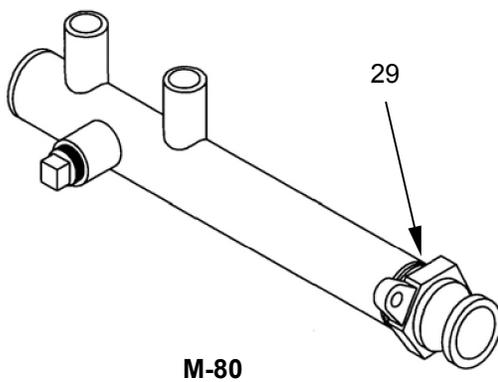
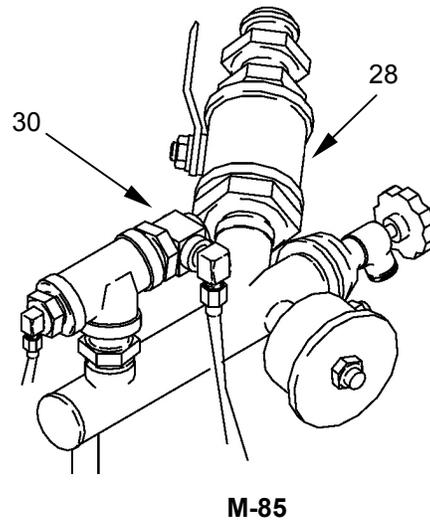
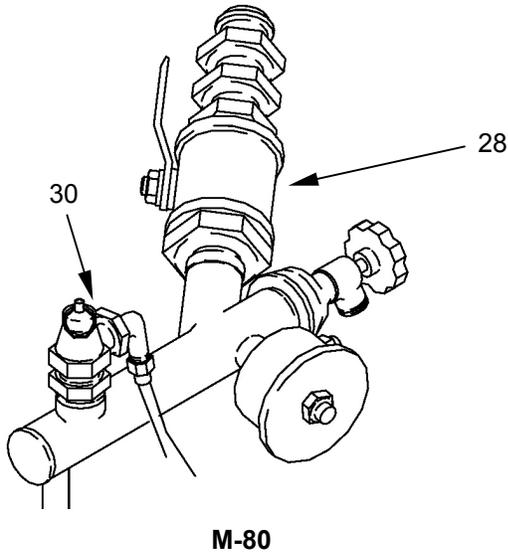
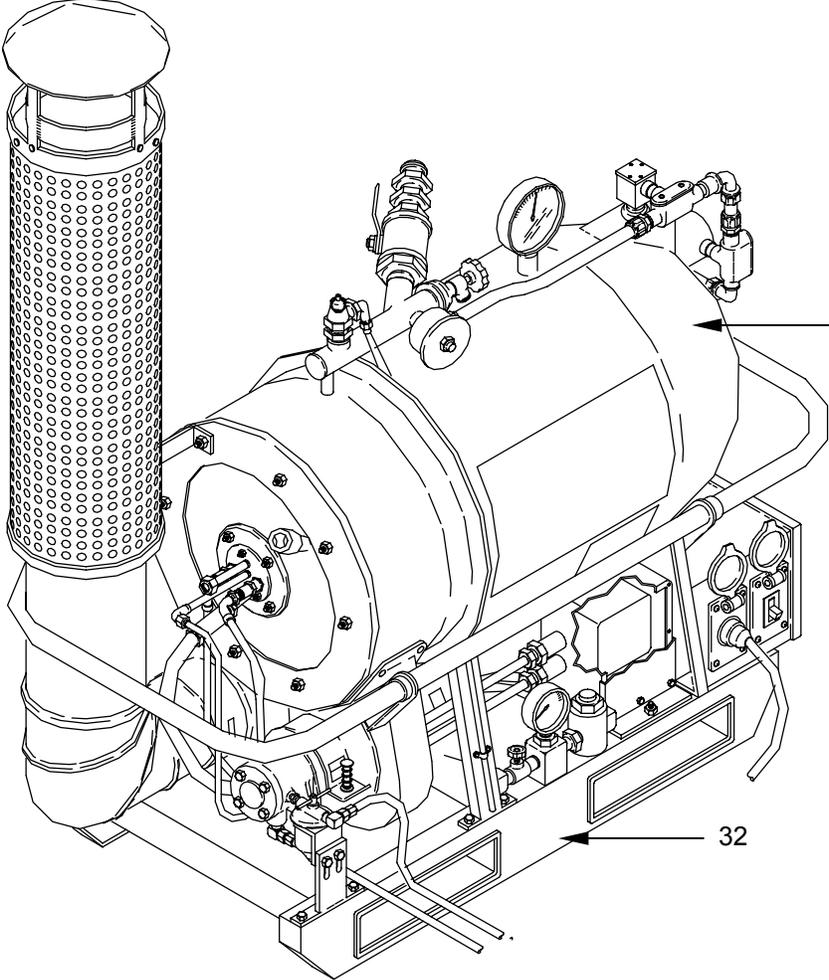

Table 1. Preventive Maintenance Checks and Services for M-80 / M-85 – continued.

ITEM NO.	INTERVAL	ITEM TO BE CHECKED OR SERVICED	PROCEDURE	EQUIPMENT NOT READY/ AVAILABLE IF:
17	Quarterly	Water Vessel and skid assemblies	Check assemblies (31) and (32) for broken welds or other damage that would affect the operation of the water heater.	Broken welds or other damage. NOTE Minor dents or burrs are acceptable if they don't affect the operation of the heater.



The image is a technical line drawing of a water heater assembly. It features a large horizontal cylindrical vessel mounted on a complex metal skid base. To the left of the vessel is a vertical cylindrical component with a perforated mesh. The drawing includes various pipes, valves, and a pressure gauge. Two callout lines with arrows point to specific areas: callout '31' points to the main cylindrical vessel, and callout '32' points to the skid base assembly.

Table 1. Preventive Maintenance Checks and Services for M-80 / M-85 – continued.

ITEM NO.	INTERVAL	ITEM TO BE CHECKED OR SERVICED	PROCEDURE	EQUIPMENT NOT READY/ AVAILABLE IF:
18	Quarterly	Control Box Assembly	 <p style="text-align: center;"><u>WARNING</u></p> <p>The water heater operates on 208VAC power. Ensure that the power has been disconnected before opening the control box access cover.</p> <p>Check the exterior/interior of the box (33) for corrosion. Check condition of toggle switch (34) and power plug (35). Open access cover (36) and inspect the inside of the box for cleanliness, damage to components, loose or broken wires.</p>	Control box is damaged. Toggle switch and /or power plug is damaged or loose. Interior components damaged, wires loose, corrosion.

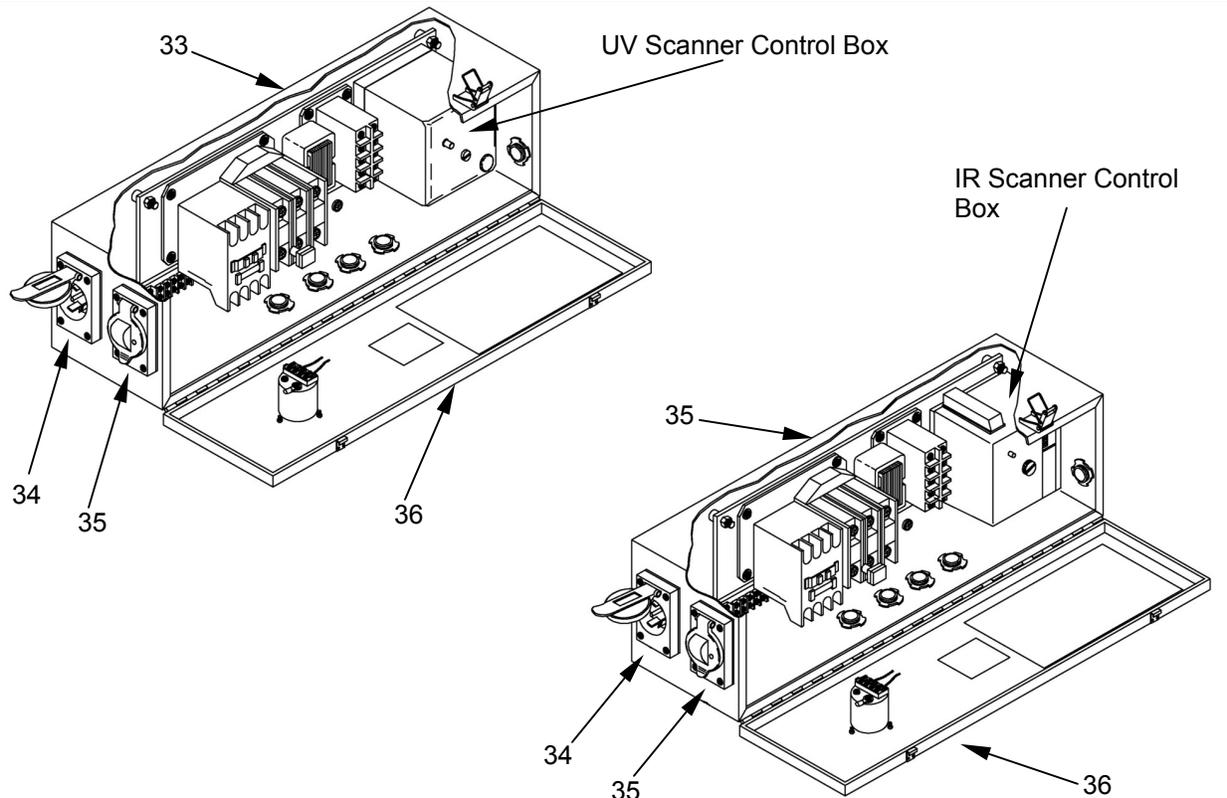
ITEM NO.	INTERVAL	ITEM TO BE CHECKED OR SERVICED	PROCEDURE	EQUIPMENT NOT READY/ AVAILABLE IF:
 <p>The image contains two technical diagrams of scanner control boxes. The left diagram is labeled 'UV Scanner Control Box' and features callouts: 33 points to the top cover, 34 points to a front panel component, 35 points to a front panel component, and 36 points to the base tray. The right diagram is labeled 'IR Scanner Control Box' and features callouts: 34 points to a front panel component, 35 points to a front panel component, and 36 points to the base tray.</p>				

END OF WORK PACKAGE

**OPERATOR MAINTENANCE
HEATER, WATER, LIQUID FUEL M-80 AND M-85
NSN 4520-01-162-0385 (M-80) 4520-01-237-3719 (M-85)
FUEL SUPPLY CONTROL COMPONENTS
INSPECT**

INITIAL SETUP:

Tools

Personnel Required

One

Materials/Parts

Equipment Condition

Water Heater set-up for operation.

INTRODUCTION

This section contains Operator Maintenance applicable to the M-80 and M85 Water Heater as authorized by the Maintenance Allocation Chart (MAC) in WP 0038 00 of this manual.

Maintenance procedures in this section can be performed by one person, unless otherwise indicated.

Read all **WARNINGS**, **CAUTIONS**, and **NOTES** carefully before attempting these procedures, including the warnings at the front of this manual.

INSPECT

1. Inspect the M-80 and M-85 fuel supply control components, consisting of the control valve (1), solenoid valve (2), gage (3), fuel line tee (4), elbows (5), nipples (6), and snubber (7). Make sure items are there and are not damaged or leaking. Check fuel gage for discoloration and legibility of dial.
2. Refer to unit maintenance for repair of these components.

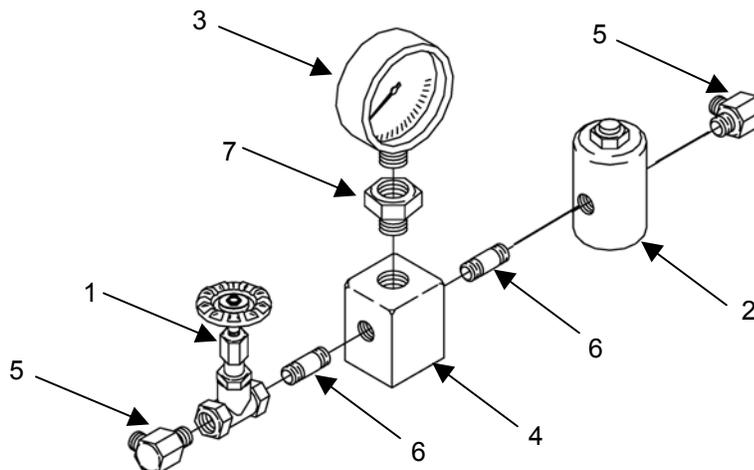

END OF WORK PACKAGE

OPERATOR MAINTENANCE
HEATER, WATER, LIQUID FUEL M-80 AND M-85
NSN 4520-01-162-0385 (M-80) 4520-01-237-3719 (M-85)
M-80 SMOKESTACK AND GUARD ASSEMBLY/M-85 EXHAUST DUCT
INSPECT

INITIAL SETUP:**Tools****Personnel Required**

One

Materials/Parts

Cloth, Cleaning (Item 1, WP 0057 00)

Equipment Condition

Water Heater set up for operation.

INSPECT**WARNING**

The smokestack, guard assembly, or exhaust duct may be hot. Do not touch these components until they have cooled down. Failure to comply may result in serious injury.

1. Inspect the M-80 guard **(1)**, smokestack **(2)**, flue support **(3)**, and elbow **(4)**, as well as the M-85 exhaust duct **(5)** for physical damage, rust and corrosion.
2. Check for proper fit. Refer to unit maintenance for repair of these components.

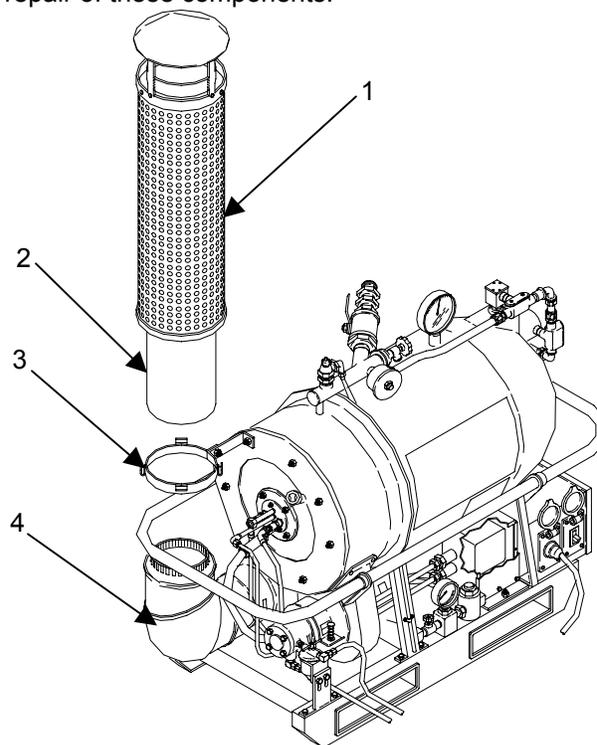
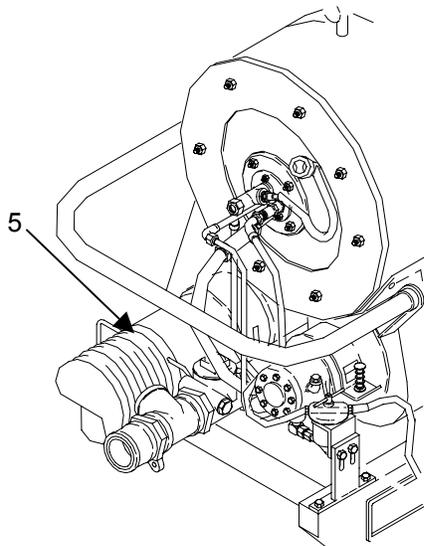
**END OF WORK PACKAGE**

OPERATOR MAINTENANCE
HEATER, WATER, LIQUID FUEL M-80 AND M-85
NSN 4520-01-162-0385 (M-80) 4520-01-237-3719 (M-85)
IGNITION CABLE ASSEMBLIES
INSPECT

INITIAL SETUP:**Tools****Personnel Required**

One

Materials/Parts

Cloth, Cleaning (Item 1, WP 0057 00)

Equipment Condition

Water Heater shut off and cooled down.

INSPECT**WARNING**

Ensure that the power distribution cable is not frayed or damaged and does not lie in standing water. Serious injuries or death to personnel by electrocution could result.

1. Place the power switch **(1)** in the **OFF** position.
2. Inspect ignition cables **(2)** for damage such as frayed, cracked or ripped insulation, loose connectors **(3)** at ignition transformer **(4)** or electrode assembly **(5)**. Refer any damage to unit maintenance.

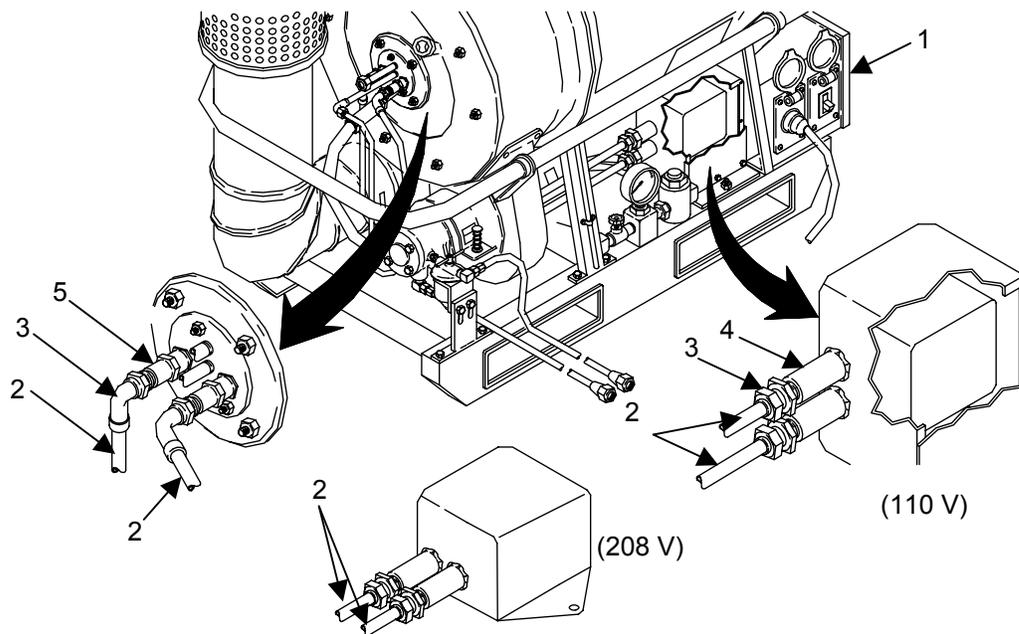
**END OF WORK PACKAGE**

OPERATOR MAINTENANCE
HEATER, WATER, LIQUID FUEL M-80 AND M-85
NSN 4520-01-162-0385 (M-80) 4520-01-237-3719 (M-85)
BLOWER ASSEMBLY
INSPECT, SERVICE, ADJUST

INITIAL SETUP:

Tools

Personnel Required

One

Materials/Parts

Cloth, Cleaning (Item 1, WP 0057 00)

Equipment Condition

Water Heater shut off and cooled down.

INSPECT

1. Inspect blower assembly **(1)** for rust, corrosion, and missing mounting hardware.
2. Inspect blower assembly for any loose hardware or leaking fuel connections on fuel pump **(2)**. Inspect for free movement of air shutter assembly **(3)**.

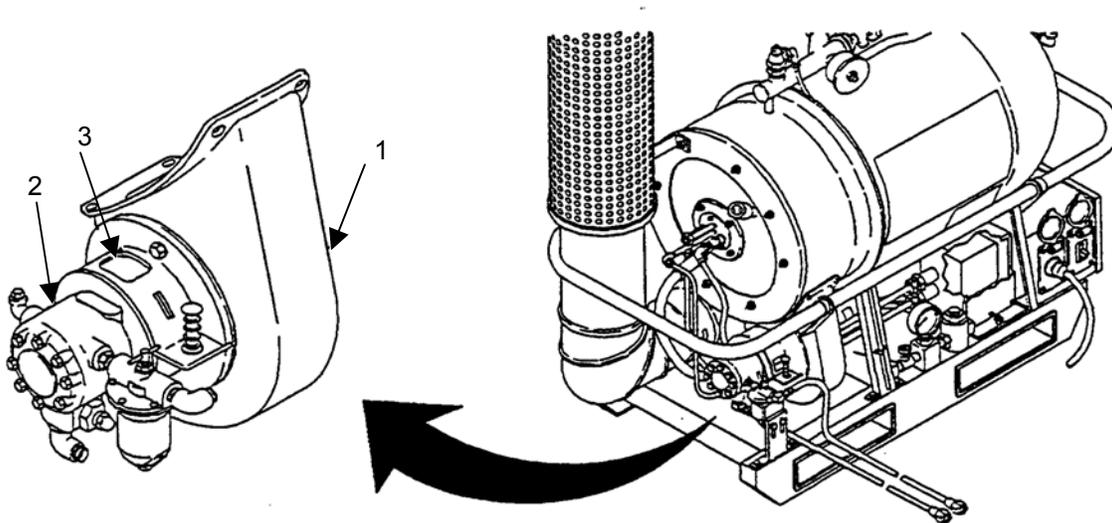

SERVICE

Service the fuel filter assembly (1) as follows:

1. Turn the handle (2) a few times to clean the permanent filter element.

NOTE

Fuel filter may differ from illustration.

2. Remove the drain plug (3) and allow moisture and sediment to drain from bowl (4). Catch the discharge in a suitable container and dispose in accordance with local regulations.
3. Reinstall drain plug (3).

ADJUST

Adjust the air opening (5) as follows:

1. Depress the air band rivet (6) and rotate the air band (7) up or down to increase or decrease the air intake.
2. Make final adjustments to the air band (7) during heater operation to obtain a transparent exhaust.

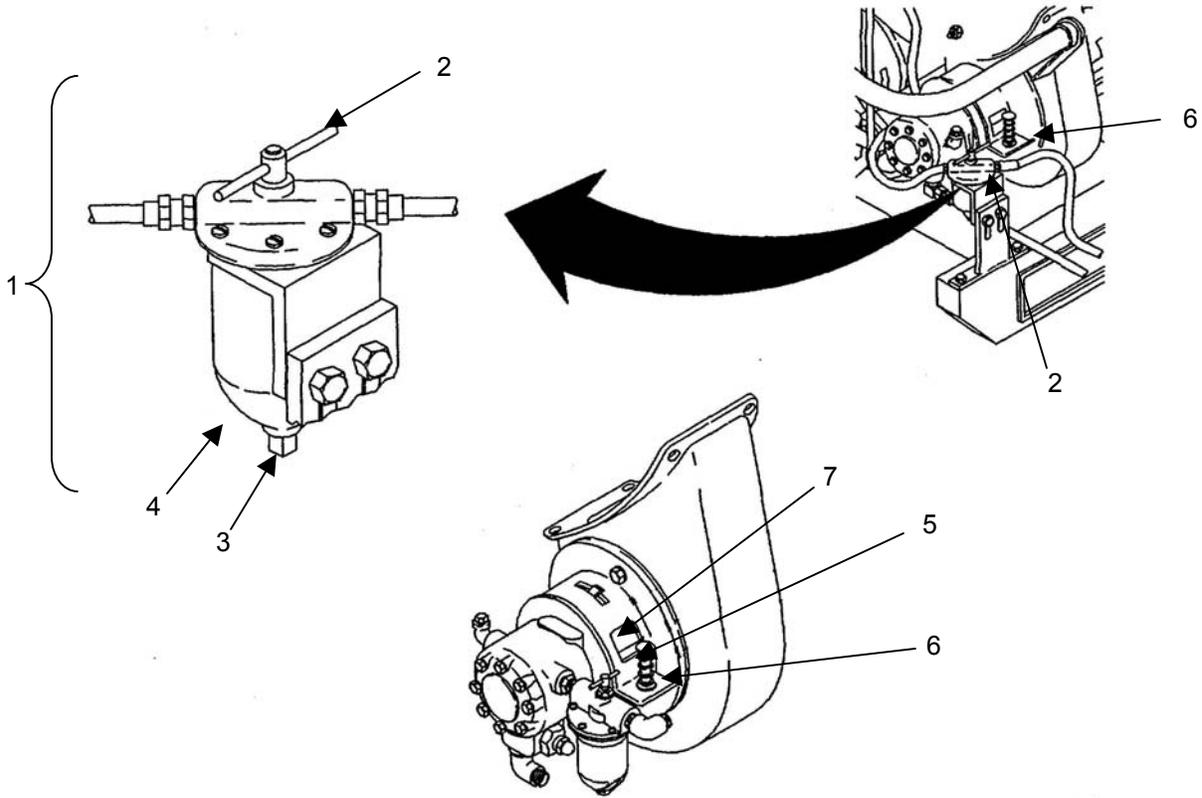

END OF WORK PACKAGE

OPERATOR MAINTENANCE
HEATER, WATER, LIQUID FUEL M-80 AND M-85
 NSN 4520-01-162-0385 (M-80) 4520-01-237-3719 (M-85)
WATER VESSEL AND SKID ASSEMBLY
INSPECT

INITIAL SETUP:**Tools**

Adjustable Wrench (Item 1, WP 0038 00)

Personnel Required

One

Materials/Parts**Equipment Condition**

Water Heater set up for operation.

INSPECT

1. Inspect the water vessel (1) and skid assembly (2) for rust, chipped paint, corrosion, and loose mounting bolts (3).
2. Check for bends or damage to skid around forklift pockets (4).
3. Verify presence and legibility of instruction plate (5) and caution decal (6).

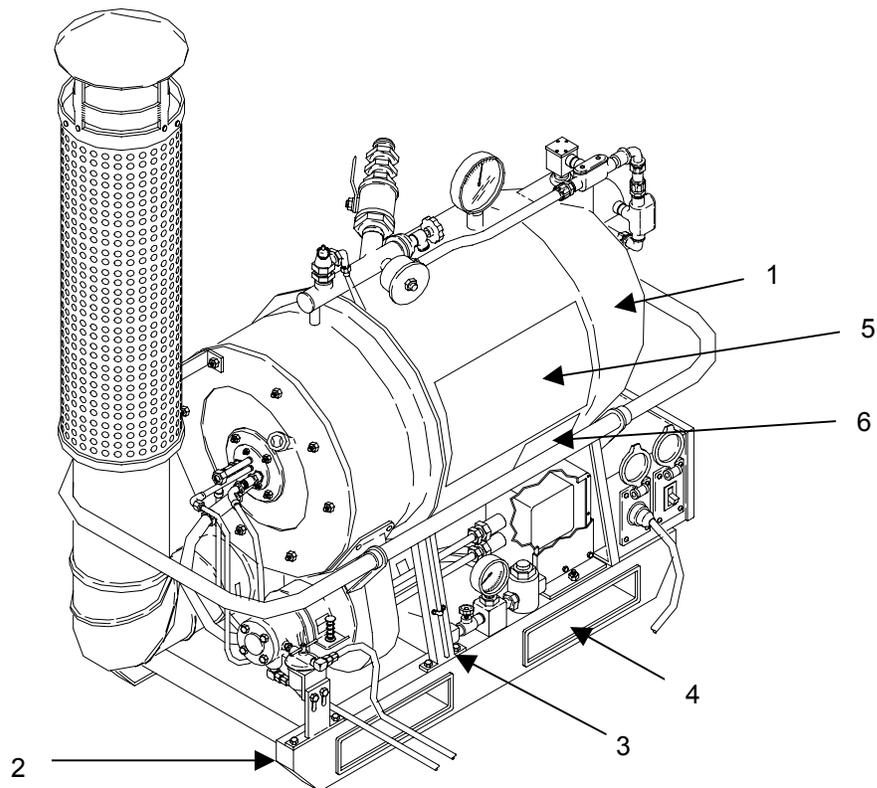
**END OF WORK PACKAGE**

CHAPTER 5

**UNIT TROUBLESHOOTING PROCEDURES
FOR
M-80 AND M-85 LIQUID FUEL WATER HEATER**

UNIT MAINTENANCE
HEATER, WATER, LIQUID FUEL, M-80 AND M-85
TROUBLESHOOTING INDEX

TROUBLESHOOTING PROCEDURES

The Malfunction Index lists common malfunctions that may occur during water heater inspection and operation.

Find the malfunction the water heater is having in the index and go to the troubleshooting procedure provided within this work package.

These charts cannot list all malfunctions that may occur, all tests or inspections needed to find the fault, nor all actions required to correct the fault. If your malfunction is not listed in, or is not correctable enough through, this troubleshooting index, notify your supervisor or unit maintenance.

DO NOT START THE TASK UNTIL:

- You understand the task.
- You understand what you are to do.
- You understand what is needed to do the work.
- You have the things you need.

MALFUNCTION SYMPTOM INDEX

Malfunction or Symptom	Refer to Troubleshooting Procedure
Water heater fails to start	1
Fuel pump leak	2
Noisy operation of fuel pump	3
Fuel pressure too high or too low	4
Fuel pump fails to deliver fuel to burner	5
Blower and fuel pump motor noisy	6
Blower motor contactor continues to trip	7
Burner fails to ignite or ignition is delayed	8
Temperature gage indicates water overheating	9
Fuel pressure pulsating	10
Flame fails during firing cycle	11
Exhaust gas or smoke exits from burner exhaust duct	12
Exhaust gas from smoke stack (M-80) or exhaust duct (M-85) is smoky	13

**WARNING**

Lethal voltage is present when the water heater is connected to a power source. Disconnect power source before inspecting or repairing any electrical component. Be careful not to touch electrical connections. Serious injury or death to personnel can result from electrical shock.

Table 1. Water Heater Troubleshooting Procedures.

MALFUNCTION	TEST OR INSPECTION	CORRECTIVE ACTION
1. Water heater fails to start.	Step 1. Check low water probe for defects.	Notify direct support maintenance if it is defective.
	Step 2. Check low water relay for defects.	Notify direct support maintenance if it is defective.
		If condition persists, notify direct support maintenance.
2. Fuel pump leaks.	Step 1. Check to see if strainer cover is loose.	Tighten all cover screws.
	Step 2. Check to see if plugs are loose.	Tighten plugs.
	Step 3. Inspect shaft seals for leaks.	Replace fuel pump, if leaking.
	Step 4. Inspect fuel pump housing for cracks.	Replace fuel pump.
3. Noisy fuel pump.	Step 1. Check suction hose for leaks.	Tighten suction hose connections. Replace suction hose if cracked or leaking.
	Step 2. Inspect fuel pump strainer for clogging.	Clean or replace fuel pump strainer.
	Step 3. Inspect fuel filter for dirt or clogging.	Clean or replace fuel filter.
	Step 4. Inspect fuel pump for overheating.	Replace fuel pump.
	Step 5. Check fuel pump for proper priming.	Prime fuel pump.
		If condition persists, notify direct support maintenance.



WARNING

Fuel is very flammable and can explode easily. To avoid serious injury or death, keep fuel away from open fire. Do not work on fuel system when burner is hot. Fuel can be ignited by hot burner. Shut off motor and do not smoke when working on fuel system.

Table 1. Water Heater Troubleshooting Procedures - continued.

MALFUNCTION	TEST OR INSPECTION	CORRECTIVE ACTION
4. Fuel pressure gage indicates pressure too low or too high.	Step 1. Check to see if fuel shutoff valve opens completely.	Replace fuel shutoff valve.
	Step 2. Check fuel pump pressure. It should be 100 psi (689 kPa).	Adjust pump pressure.
	Step 3. Check fuel filter for clogs or dirt.	Clean fuel filter.
	Step 4. Check for breaks or restrictions in fuel hoses or loose couplings.	Tighten couplings, remove restrictions in fuel hoses or loose couplings.
	Step 5. Check fuel pressure gage for defects.	Replace fuel pressure gage.
	Step 6. Check fuel nozzle for clog or defects.	Clean or replace fuel nozzle.
		If condition persists, notify direct support maintenance.



WARNING

Fuel is very flammable and can explode easily. To avoid serious injury or death, keep fuel away from open fire. Do not work on fuel system when burner is hot. Fuel can be ignited by hot burner. Shut off motor and do not smoke when working on fuel system.

Table 1. Water Heater Troubleshooting Procedures - continued.

MALFUNCTION	TEST OR INSPECTION	CORRECTIVE ACTION
5. Fuel pump fails to deliver fuel to burner.	Step 1. Check for reversed pump rotation.	Interchange any two of the three 208 volt 3-phase electrical supply lines at the power source.
	Step 2. Check fuel nozzle for clogs.	Clean fuel nozzle. Replace if necessary.
	Step 3. Check to see if fuel pump drive coupling is loose.	Tighten fuel pump drive coupling.
	Step 4. Check to see if solenoid valve activates.	Notify direct support maintenance if it does not activate.
	Step 5. Inspect fuel hoses for restrictions.	Disconnect and remove restriction from fuel hose, or replace hose as necessary.
		If condition persists, notify direct support maintenance.
6. Blower and fuel pump motor are noisy.	Step 1. Inspect blower for any obstructions.	Remove obstructions
	Step 2. Check for overheated blower.	Check for obstructions or binding.
	Step 3. Loosen setscrew at fuel pump shaft and check blower rotation.	If noise continues, replace blower.
		If noise ceases, replace fuel pump.
		If condition persists, notify direct support maintenance.
7. Blower motor contactor continues to trip.	Step 1. Inspect fuel pump and motor for obstructions or binding.	
	Step 2. Loosen set screw at fuel pump and check blower rotation.	Replace fuel pump.
		If condition persists, notify direct support maintenance.

Table 1. Water Heater Troubleshooting Procedures - continued.

MALFUNCTION	TEST OR INSPECTION	CORRECTIVE ACTION
<p>8. Burner fails to ignite or ignition is delayed.</p>	<p>Step 1. Determine if sufficient fuel is in the fuel container.</p>	<p>Fill fuel container.</p>
	<p>Step 2. Determine if fuel is contaminated with water.</p>	<p>Drain fuel supply into another container and refill fuel container with uncontaminated fuel.</p>
	<p>Step 3. Inspect spark plugs for carbon deposits.</p>	<p>Clean spark plugs.</p>
	<p>Step 4. Inspect spark plugs for proper adjustment.</p>	<p>Adjust spark plugs.</p>
	<p>Step 5. Inspect ignition transformer for damage.</p>	<p>Replace ignition transformer.</p>
	<p>Step 6. Determine if cable assembly connection from transformer to burner is disconnected.</p>	<p>Reconnect if disconnected.</p>
	<p>Step 7. Inspect spark plug porcelain for breaks or cracks.</p>	<p>Replace spark plug.</p>
		<p>If condition persists, notify direct support maintenance.</p>
<p>9. Water temperature gage indicates water overheating.</p>	<p>Step 1. Inspect 320-250 °F (0-121 C) temperature control setting and determine if it is set too high.</p>	<p>Adjust 320-250 °F temperature control.</p>
	<p>Step 2. Inspect 320-250 °F temperature control for any defects.</p>	<p>Replace 320-250 °F temperature control.</p>
	<p>Step 3. Determine if low water probe is defective.</p>	<p>Notify direct support maintenance if any defects are found.</p>
		<p>If condition persists, notify direct support maintenance.</p>

Table 1. Water Heater Troubleshooting Procedures - continued.

MALFUNCTION	TEST OR INSPECTION	CORRECTIVE ACTION
<p>10. Pressure gage indicates pulsating pressure.</p>	Step 1. Inspect suction hose for leaks.	Tighten suction hose connections.
	Step 2. Inspect strainer cover for loose hardware.	Tighten cover screws.
	Step 3. Inspect fuel pump strainer for clogging.	Clean or replace fuel pump strainer.
	Step 4. Inspect fuel filter for dirt or clogging.	Clean or replace fuel filter.
	Step 5. Inspect burner nozzle for defects.	Replace burner nozzle.
	Step 6. Inspect fuel pressure gage for defects.	Replace fuel pressure gage.
If condition persists, notify direct support maintenance.		
<p>11. Flame failure during firing cycle.</p>	Step 1. Check fuel nozzle for dirt and clogs.	Clean or replace nozzle.
	Step 2. Check UV/IR scanner sight tube to see if it is clogged.	Clear obstructions from UV/IR scanner sight tube.
	Step 3. Check operation of flame safeguard control to see if it is defective.	Push flame lockout button for rest. Notify direct support maintenance if control does not reset.
	Step 4. Check UV/IR scanner for defects.	Notify direct support maintenance if a defect is found.
	Step 5. Inspect fuel pump strainer to see if it is clogged.	Remove and clean strainer.
	Step 6. Check fuel pump coupling for looseness.	Tighten fuel pump drive coupling.
	Step 7. Check fuel pump for defects.	Replace fuel pump.
	Step 8. Check power to solenoid fuel valve at terminal board.	Notify direct support maintenance if voltage is not present.
	Step 9. Check solenoid fuel valve for defects.	Replace solenoid fuel valve.
If condition persists, notify direct support maintenance.		

Table 1. Water Heater Troubleshooting Procedures - continued.

MALFUNCTION	TEST OR INSPECTION	CORRECTIVE ACTION
12. Smoke escaping from around smoke-box cover.	Step 1. Inspect smoke box gasket for excess wear and deterioration.	Replace gasket if necessary.
	Step 2. Determine if nuts securing smoke box cover and burner head assembly are tightened properly.	Tighten nuts around smoke box cover.
		If condition persists, notify direct support maintenance.
13. Exhaust gas from smoke stack (M-80) or exhaust duct (M-85) is smoky.	Step 1. Inspect burner spark plug spark.	Adjust or replace spark plug.
	Step 2. Determine if fuel is contaminated.	Drain fuel supply into another container and refill fuel container with an uncontaminated fuel.
	Step 3. Determine if fuel nozzle or screen is clogged.	Clean or replace clogged nozzles.
	Step 4. Inspect blower operation for obstruction.	Loosen setscrew at fuel pump shaft and check blower operation.
	Step 5. Determine if power source provides adequate voltage.	If power source is adequate, notify your supervisor.
		If condition persists, notify direct support maintenance.

END OF WORK PACKAGE

CHAPTER 6

**UNIT MAINTENANCE INSTRUCTIONS
FOR
M-80 AND M-85 LIQUID FUEL WATER HEATER**

UNIT MAINTENANCE
HEATER, WATER, LIQUID FUEL M-80 AND M-85
NSN 4520-01-162-0385 (M-80) 4520-01-237-3719 (M-85)
FUEL SUPPLY CONTROL COMPONENTS
INSPECT, REMOVE, REPAIR, INSTALL

INITIAL SETUP:**Tools**

Tool Kit, General Mechanic's, Automotive (Item 3, WP 0038 00)

Tool Kit, Organizational Maintenance Common No.1 (Item 4, WP 0038 00)

Personnel Required

One

Materials/Parts

Solvent, dry cleaning (Item 12, WP 0057 00)

Sealer (Item 10, WP 0057 00)

Cloth, cleaning (Item 11, WP 0057 00)

Tag (Item 13, WP 0057 00)

Equipment Condition

Water heater shut down, cooled down, power disconnected.

INSPECT

Inspect the fuel control assembly for loose fitting components, leaks, corrosion, and evidence of physical damage. Check fuel gage for discoloration and legibility of dial. Replace a malfunctioning component as described in this work package.

REMOVE

WARNING

When removing fuel supply control assembly components, avoid fuel spills. Igniting fuel or explosion could result in serious injury or death to personnel.

To remove the fuel supply control assembly components, proceed as follows:

1. With power disconnected and control switch **(1)** set to **OFF**, open control box **(2)**, tag and disconnect the fuel solenoid leads (black) **(3)** from the terminal board **(4)**.
2. Remove nut **(5)** and conduit **(6)** from elbow **(7)**.
3. Remove elbow **(7)** from bottom of control box **(2)**.
4. Disconnect fuel lines **(8)** and **(9)**, from elbow fittings **(10)** and **(11)**.
5. Disconnect conduit **(12)** from fuel solenoid **(13)**.
6. Remove two screws **(14)** and washers **(15)** securing fuel line Tee **(16)** to the heater frame.
7. Remove the entire fuel supply control assembly **(17)** (pull fuel solenoid wires out of the conduit **(12)**).
8. Remove the fuel line **(18)** from the burner head assembly **(19)** by unscrewing it from the adapter **(20)**.
9. Remove the fuel line **(21)** and elbow fitting **(22)** from the fuel pump.

10. Remove the control valve (23) by unscrewing the elbow fitting (10) and nipple (24).
11. To remove the fuel line Tee (16), unscrew two nipples (24).
12. To remove gage (25), unscrew the snubber (26).
13. Remove the elbow (11) and nipple (24) from the solenoid (13).

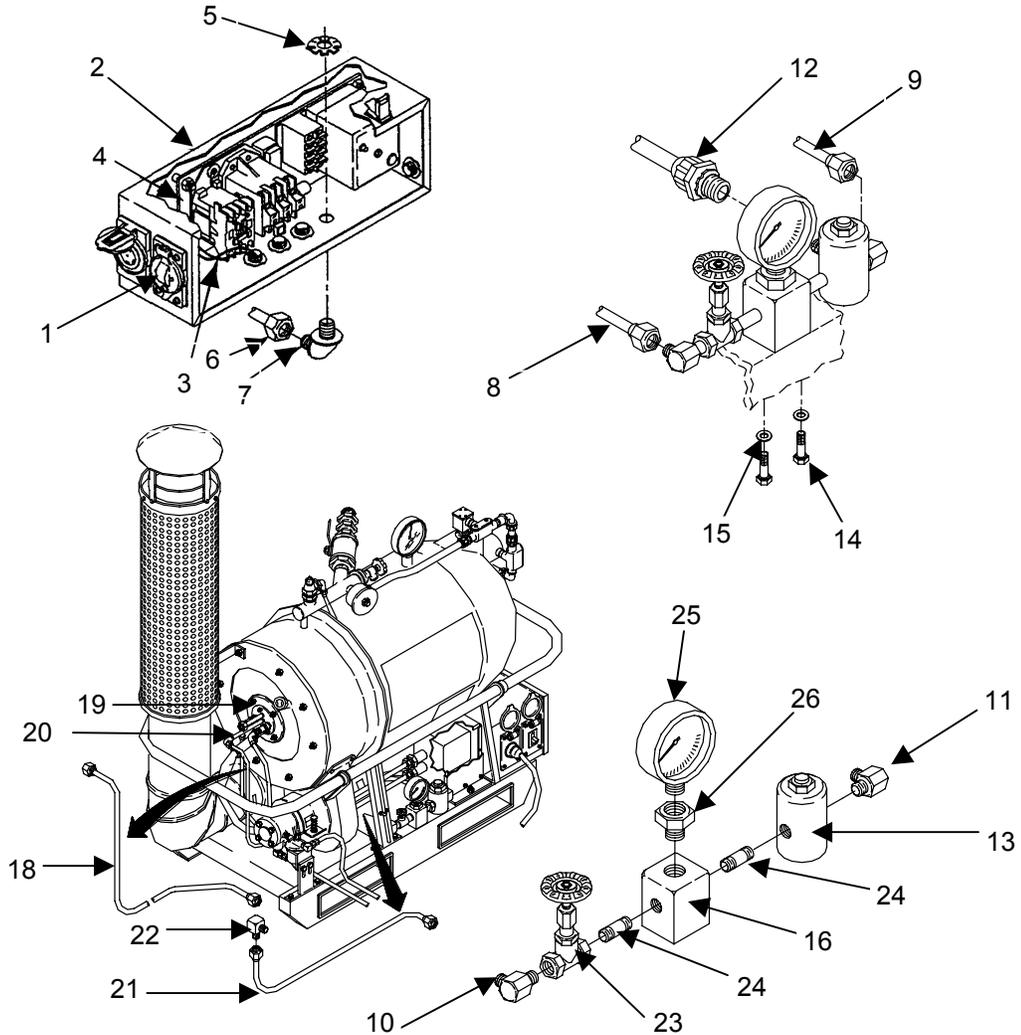

REPAIR

Repair the fuel supply control assembly by replacing any defective component.

INSTALL



WARNING

Dry-cleaning solvent, P-D-680, Type III is potentially dangerous. Avoid repeated or prolonged breathing of vapors and skin contact with liquid. Do not use near open flame, arcing equipment, or other ignition sources. Use only in well ventilated area.

NOTE

Apply sealer when joining pipes, fittings and other components of the fuel supply control assembly.

1. Install two nipples, **(1)** and snubber **(2)** into fuel line Tee **(3)** by turning components clockwise.
2. Install gage **(4)** into snubber **(2)**.
3. Install the control valve **(5)** onto the nipple **(1)**.
4. Install elbow **(6)** onto control valve **(5)**.
5. Install solenoid valve **(7)** onto the nipple **(1)**.
6. Install elbow **(8)** onto solenoid valve **(7)**.
7. Insert fuel solenoid valve wires into conduit **(9)** and install fuel supply control assembly **(10)** to water heater skid using two screws **(11)** and two washers **(12)**. Tighten screws.
8. Connect conduit **(13)** onto the solenoid valve **(7)**.
9. Connect fuel line **(14)** to elbow fitting **(15)** and other end to elbow **(6)** on fuel supply control assembly **(10)**. Tighten all couplings.
10. Connect fuel line **(16)** to adapter **(18)** and burner head assembly **(18)**. Tighten all couplings.
11. Replace elbow **(19)** at bottom of control box **(20)**. Secure with nut **(21)**.
12. At control box reconnect solenoid valve leads to the terminal board **(22)**, and reinstall conduit **(23)** to elbow **(19)**.
13. To start the water heater follow procedures in work package 0005 00 under Initial Adjustments and Operating Procedures.

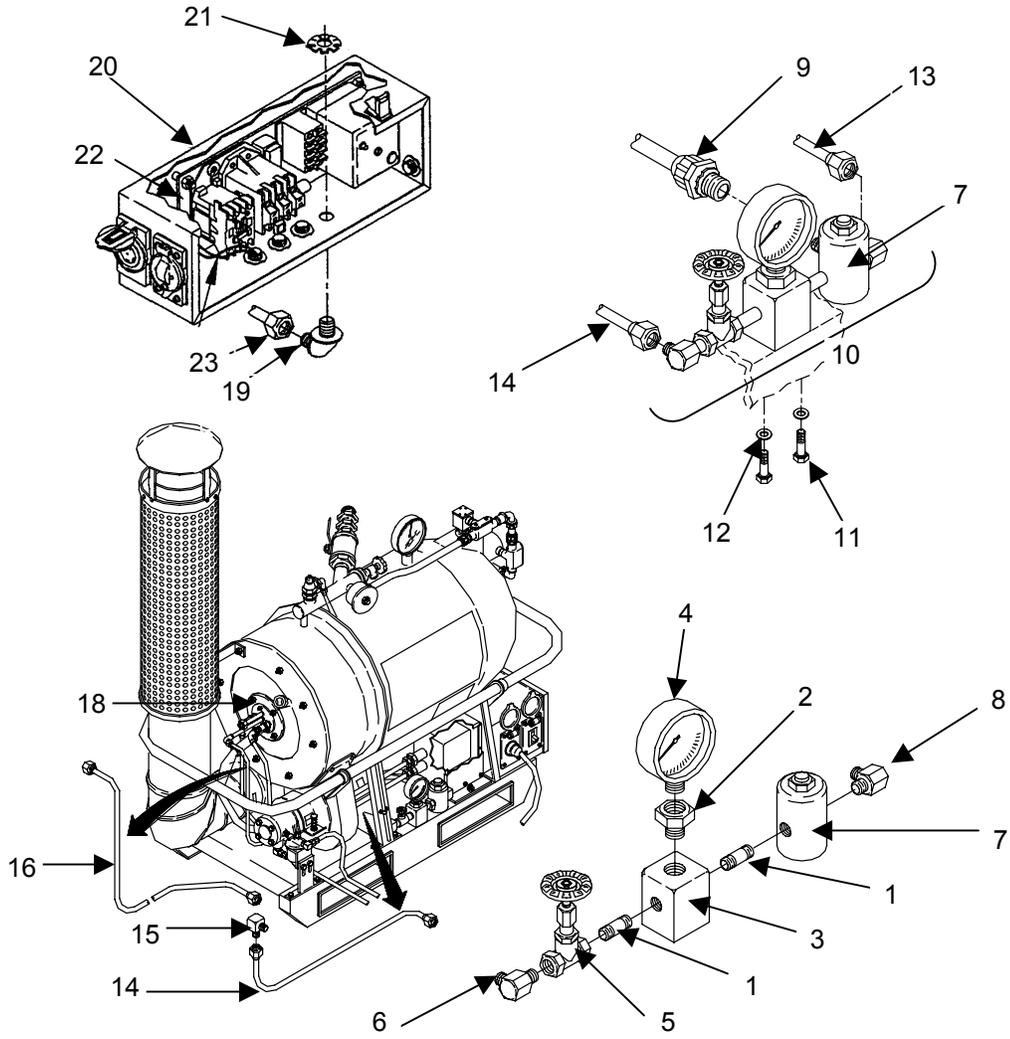

END OF WORK PACKAGE

UNIT MAINTENANCE
HEATER, WATER, LIQUID FUEL M-80 AND M-85
NSN 4520-01-162-0385 (M-80) 4520-01-237-3719 (M-85)
BURNER HEAD ASSEMBLY
INSPECT, REMOVE, REPAIR, INSTALL

INITIAL SETUP:

Tools

Tool Kit, General Mechanic's, Automotive (Item 3, WP 0038 00)

Personnel Required

One

Materials/Parts

Solvent, Dry Cleaning (Item 12, WP 0057 00)
 Cloth, Cleaning (Item 1, WP 0057 00)
 Gasket, Spark Plug (Item 1, WP 0057 00)
 Gasket, Peep Sight (Item 10, WP 0057 00)

Equipment Condition

Water heater shut down, cooled down, power disconnected.

INSPECT

Inspect burner head assembly for loose fitting components or corrosion, leaks, and evidence of physical damage.

REMOVE

To remove the burner head assembly, proceed as follows:



WARNING

Contact with the high voltage present in the water heater can cause severe injuries or death to personnel. Disconnect power before performing this procedure.

1. With power disconnected and control switch set to **OFF**, disconnect two ignition cable assemblies (1) and fuel line (2) from the burner head assembly.

CAUTION

The scanner is a sensitive device. Rough handling can damage the scanner and result in possible failure of the flame safeguard control.

2. Disconnect the scanner (3) from the burner head assembly.
3. Remove three nuts (4) and three washers (5) mounting the electrode assembly (6) to the burner tube (7). Remove electrode assembly (6) from burner tube (7) and set aside.
4. Remove four nuts (8) and four washers (9) from burner tube (7). Remove burner tube (7) and gasket (10) from water heater.
5. Inspect inside of burner tube (7). Note any damage and set aside.

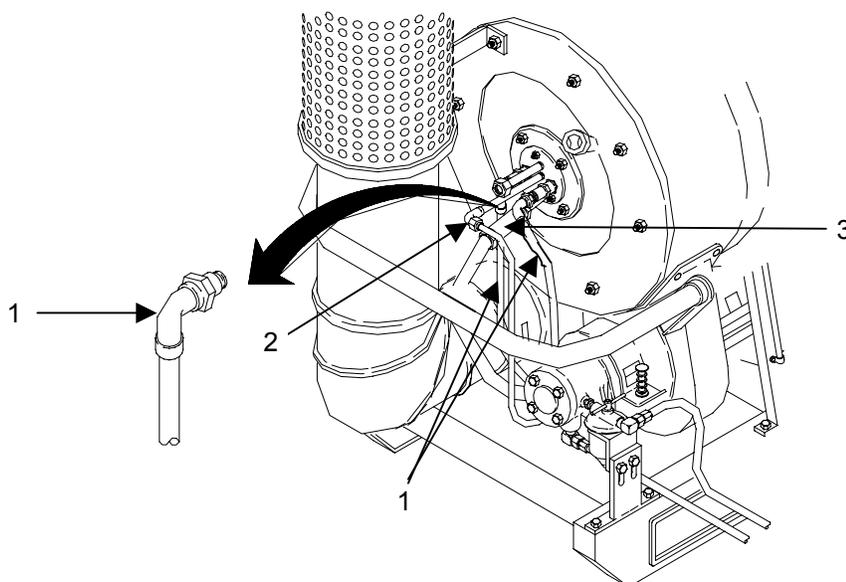

6. Unscrew and remove spark plugs (11) and gaskets (12) from electrode holder (13).
7. Unscrew and remove fuel nozzle (14) and adapter (15) attached to nipple (16).

NOTE

Mark position of nipple on electrode holder before removing it to ensure proper position during reinstallation.

8. Remove nipple (16) by loosening set screw (17) on electrode holder (13). Remove elbow (18) from nipple (16).
9. Unscrew and remove ignition sight tube (19 through 22) from electrode holder (13).

CAUTION

Be careful not to drop the peep site. The sight glass is easily damaged.

10. Unscrew and remove peep sight cap (19) from nipple (20).
11. Remove peep site glass (21) and two peep sight gaskets (22). Separate gaskets from glass.
12. Unscrew and remove close nipple (23) from coupling (24).
13. Unscrew and remove coupling (24) from bushing (25).
14. Unscrew and remove bushing (25) from scanner tube (26).
15. Loosen setscrew (27) securing scanner tube (26) to electrode holder (13).

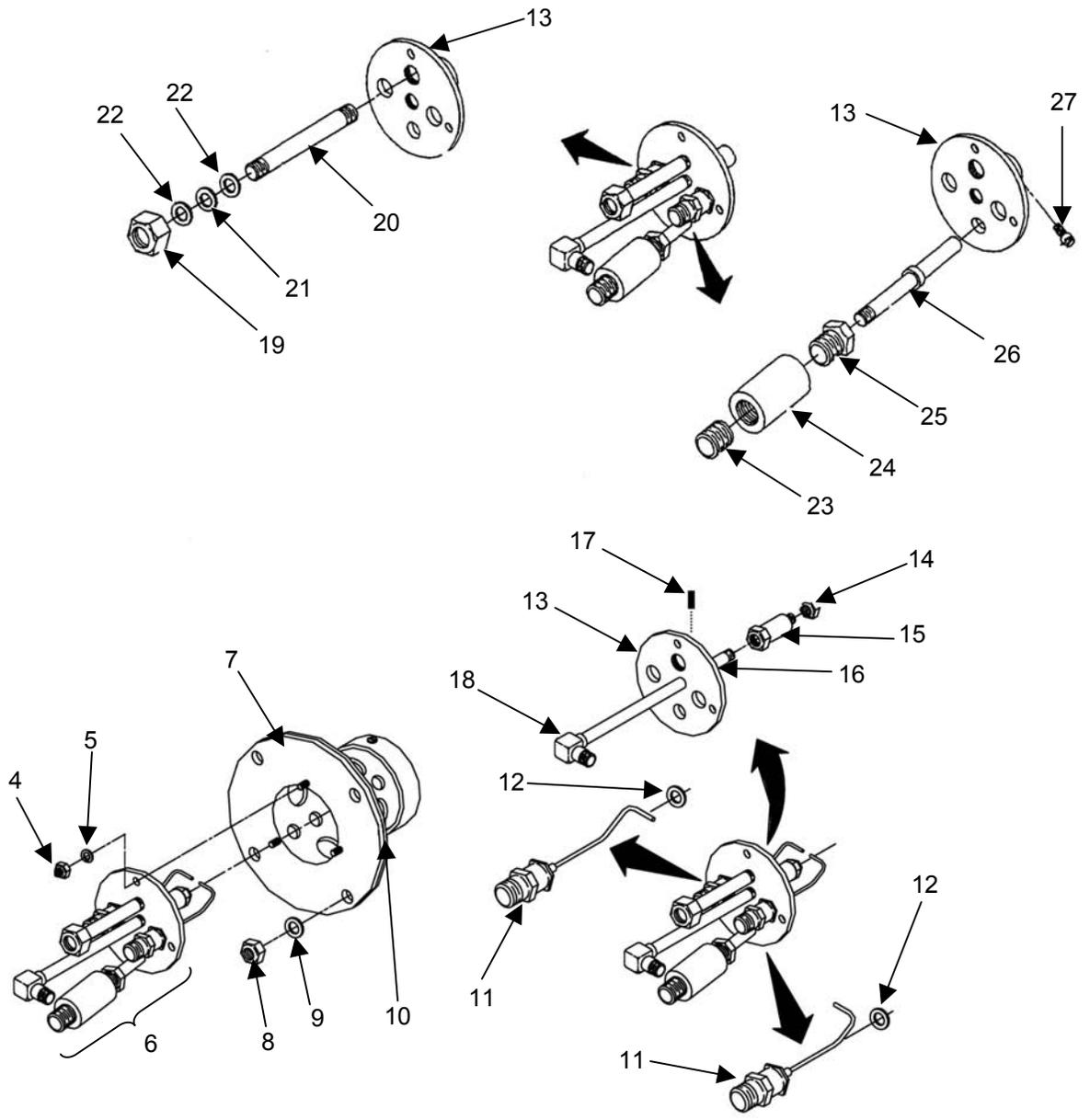

REPAIR

1. Repair the burner head assembly by replacing any defective components. Inspect spark plugs **(1)** for burned spots and cracks or breaks in insulation. Inspect nozzle **(2)** for cracks, clogs, excessive wear or carbon deposits. Inspect electrode holder **(3)** for breaks, cracks or damaged threads. Inspect adapter **(4)**, nipple **(5)** and elbow **(6)** for damaged threads. Inspect sight tube **(7 through 10)** for damaged threads, breaks or cracks in sight glass **(9)**. Replace gaskets **(10)**. Inspect close nipple **(11)**, coupling **(12)**, bushing **(13)**, scanner tube **(14)**, and set screw **(15)** for damaged threads. Inspect for clogged or obstructed tube.
2. Wash spark plugs **(1)** with soapy water, rinse with clean water, and let dry thoroughly.

CAUTION

Use extreme care when cleaning nozzle to avoid damaging orifice tip. Do not force wire or any metallic object through the nozzle orifice.

**WARNING**

Dry-cleaning solvent, P-D-680, Type III is potentially dangerous. Avoid repeated or prolonged breathing of vapors and skin contact with liquid. Do not use near open flame, arcing equipment, or other ignition sources. Use only in well ventilated area. Failure to comply may cause serious injury or death.

3. Soak and clean nozzle **(2)** and adapter with solvent. Let parts dry thoroughly.
4. Wash sight glass **(9)** in soapy water, rinse in clean water and let dry thoroughly.
5. Wash scanner tube **(14)** in solvent to remove deposits in tube and let dry thoroughly.

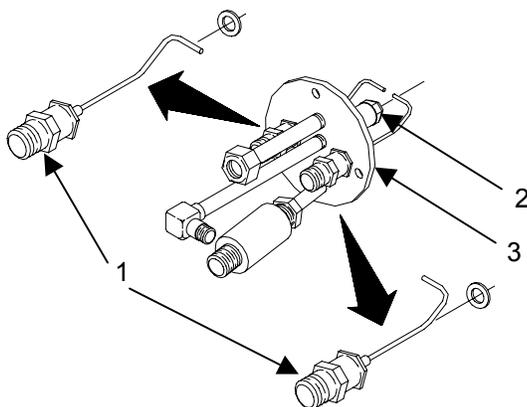

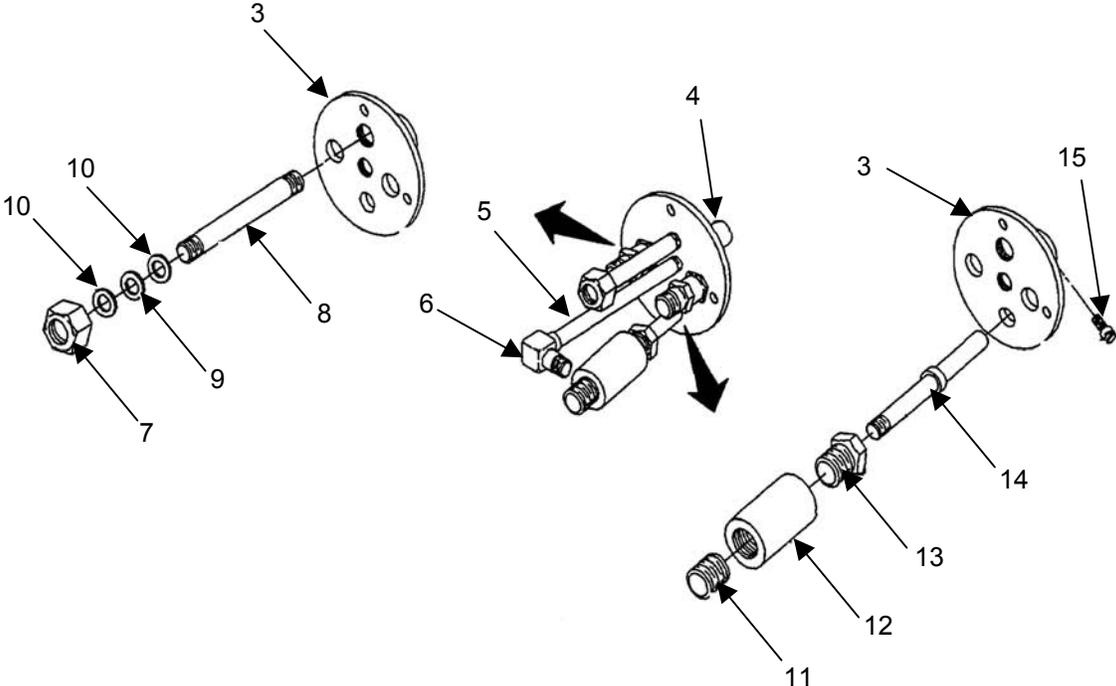

INSTALL

1. Screw close nipple (1) and bushing (2) into coupling (3) by turning clockwise.
2. Screw scanner tube (4) into bushing (2). Insert scanner tube (4) into electrode holder (5) and tighten set screw (6).
3. Assemble two gaskets (7) and peep sight glass (8), insert it into peep sight cap (9), and then screw in nipple (10).
4. Install nipple (10) into electrode holder (5) by turning clockwise.

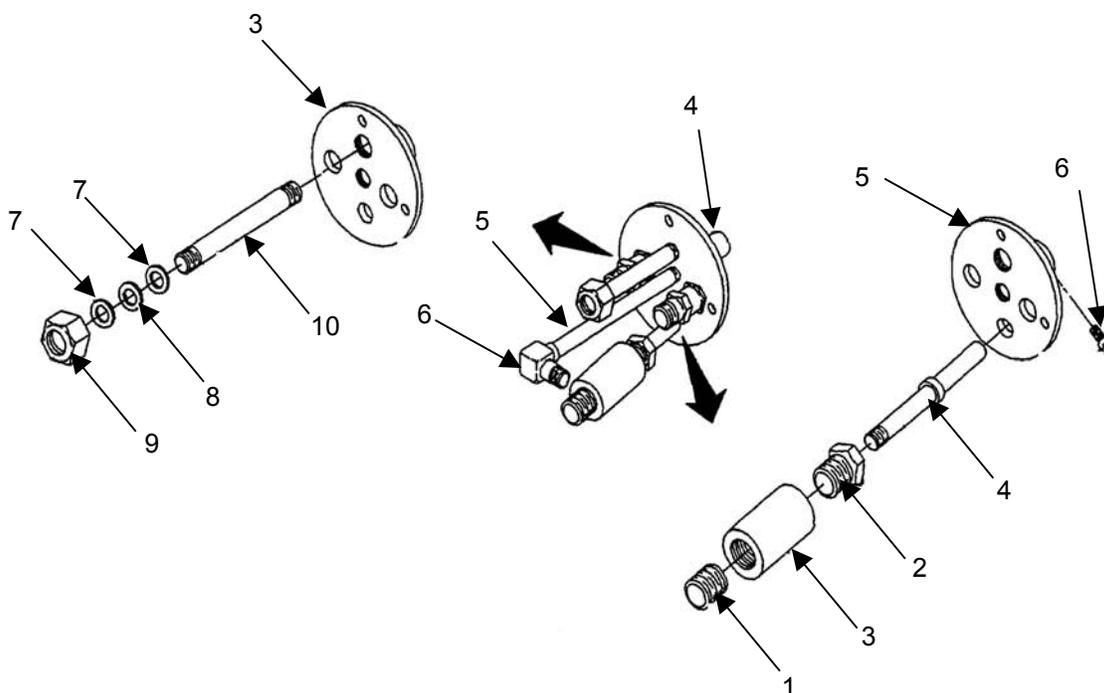

5. Install elbow (11) onto nipple (12) and screw into electrode holder (5).
6. Screw nozzle adapter (13) to end of nipple (12) and install nozzle (14) onto nozzle adapter (13).

NOTE

Spark plugs are designated left hand and right hand. Be sure to install spark plug in correct position.

7. Place new gasket (16) over electrode and install spark plug (17). Repeat procedure for other spark plug.

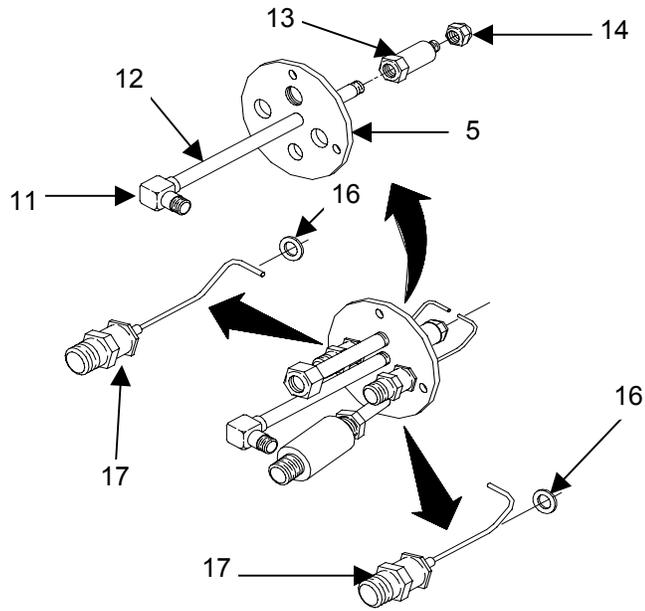

8. Bend spark plug electrodes (18) until spark gap is 5/32 inch (4 mm) and electrodes are located 1/8 inch (3mm) outward and 1/2 inch (13 mm) upward from hole in burner nozzle.

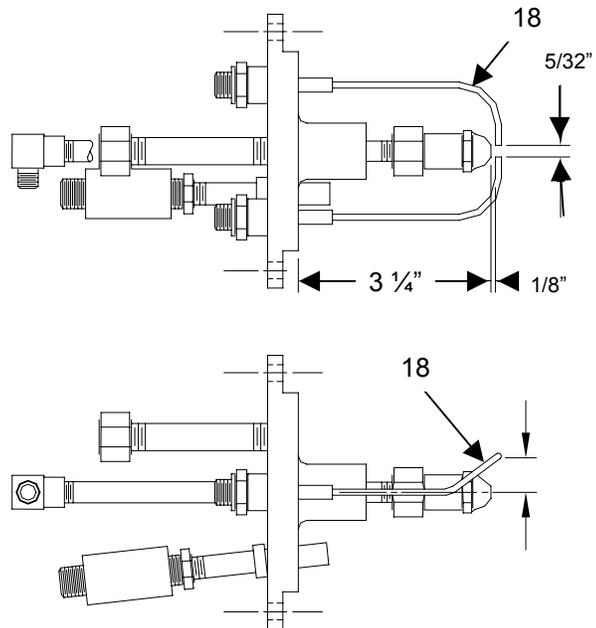

9. Install electrode assembly (1) in burner tube (2) using three washers (3) and three nuts (4). Tighten nuts.
10. Install burner tube (2) and gasket (5) in water heater using four washers (6) and nuts (7). Tighten nuts.

CAUTION

The scanner is a sensitive device. Rough handling can damage the scanner and result in possible failure of the flame safeguard control.

11. Inspect scanner (8) for dirt and foreign matter. Clean with a soft cloth if necessary. If scanner is broken or damaged, notify direct support maintenance.
12. Connect scanner (8) to nipple (9).
13. Connect two ignition cable assemblies (10) to two spark plugs (11).
14. Connect fuel line coupling (12) to elbow (13).

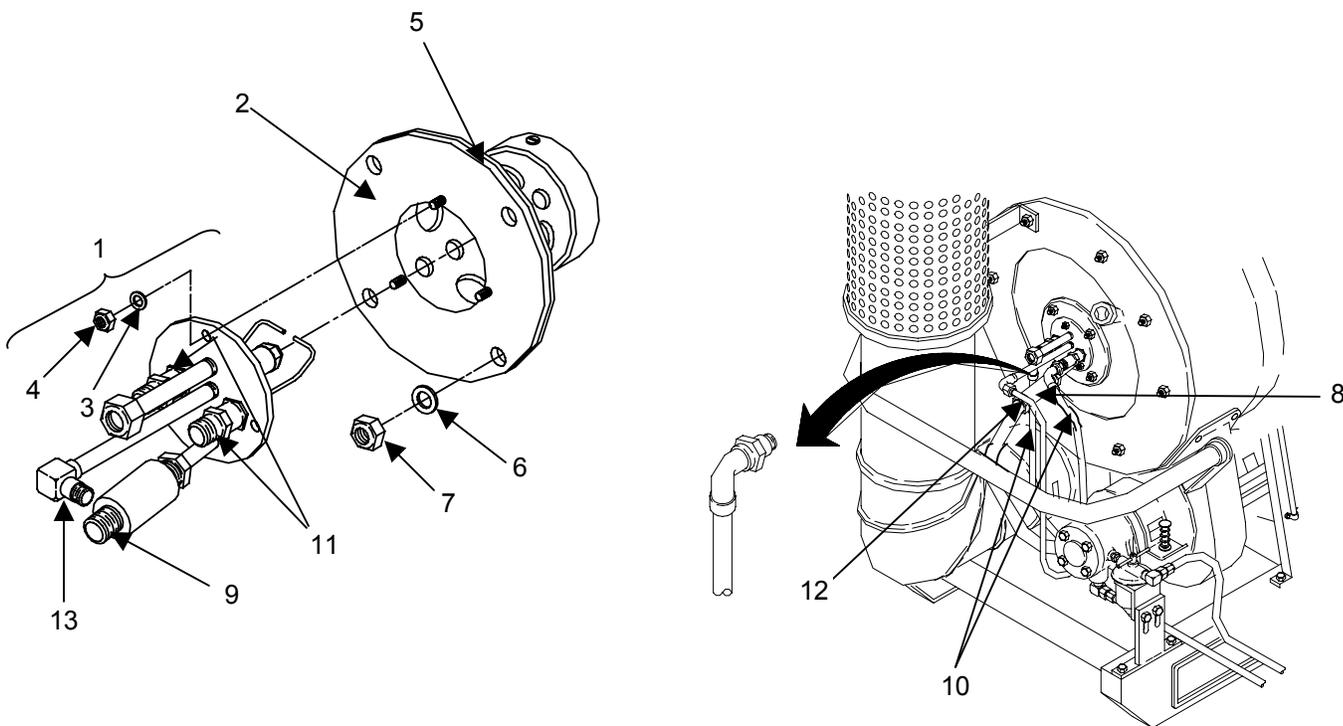

END OF WORK PACKAGE

UNIT MAINTENANCE
HEATER, WATER, LIQUID FUEL M-80 AND M-85
NSN 4520-01-162-0385 (M-80) 4520-01-237-3719 (M-85)
SMOKESTACK AND GUARD ASSEMBLY M-85, EXHAUST DUCT M-80
INSPECT, REMOVE, INSTALL

INITIAL SETUP:**Tools**

Tool Kit, General Mechanic's, Automotive (Item 3, WP 0038 00)

Personnel Required

One

Materials/Parts

Cloth, Cleaning (Item 1, WP 0057 00)

Equipment Condition

Water heater shut down, cooled down, power disconnected.

INSPECT

1. Inspect the smokestack and guard assembly for physical damage, corrosion, and rust.
2. Check flue support bracket and elbow for security.
3. Check smokestack / exhaust duct for proper fit. Clean out smokestack or duct if necessary.
4. Replace any damaged or worn out component.

REMOVE

WARNING

Prior to starting any work on the smokestack or exhaust duct, allow the water heater to cool down. Failure to do so may result in serious injuries.

To remove the smokestack and guard assembly on the M-80 Water Heater, proceed as follows:

1. Grasp guard assembly **(1)** and lift upward to clear the smokestack **(2)**.
2. Separate the two smokestack sections **(2)**.
3. Remove the nut **(3)**, screw **(4)**, and washer **(5)** on flue support bracket **(6)** and remove the smokestack **(2)**.
4. Twist elbow section **(7)** to the left and pull off mounting studs **(8)** to remove it.

To remove the exhaust duct on the M-85 Water Heater, proceed as follows:

Disconnect the exhaust duct **(9)** by separating it from the exhaust collar **(10)**.

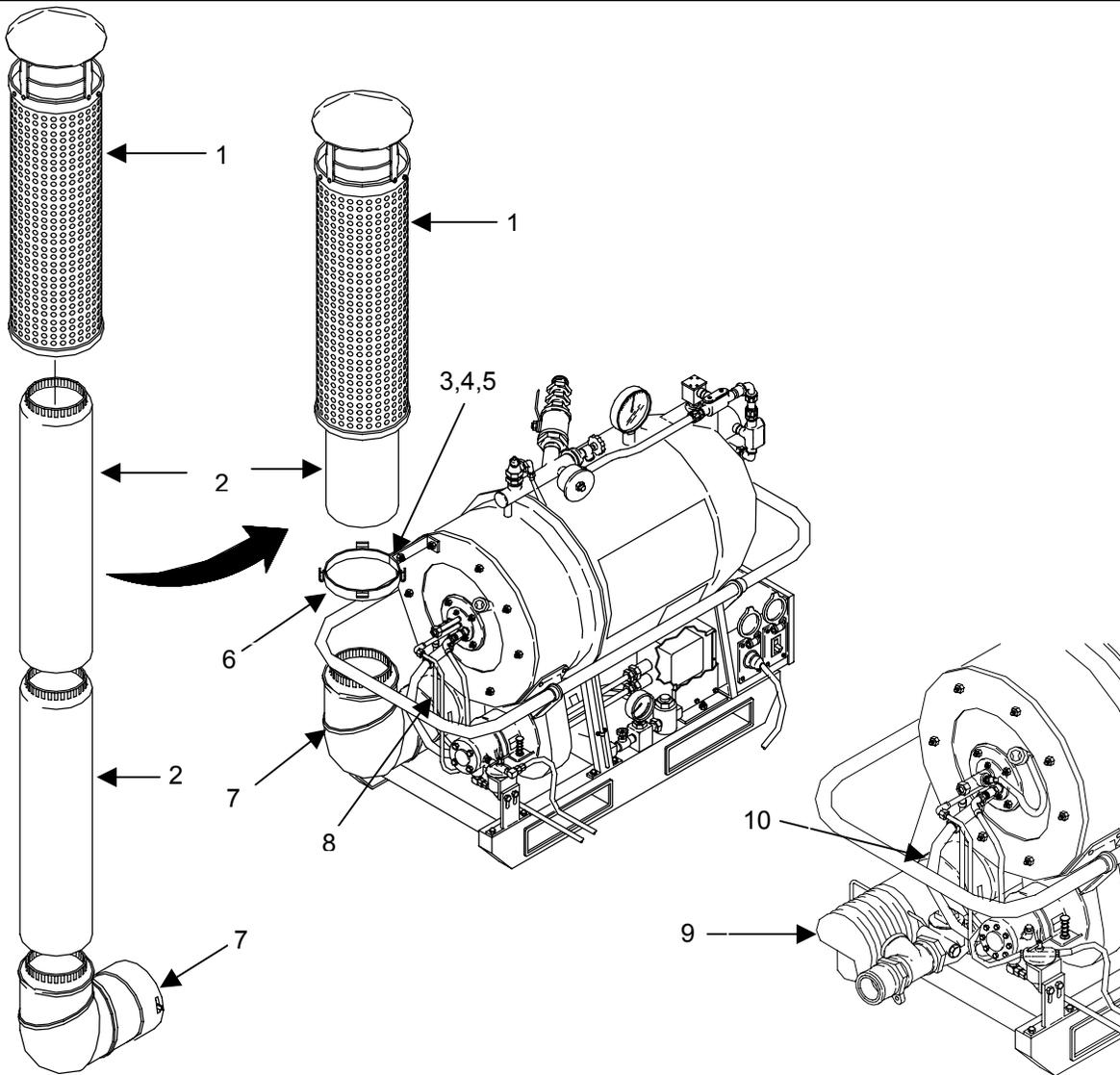

INSTALL

To install the smokestack and guard assembly on the M-80 Water Heater, proceed as follows:

1. Place elbow (7) over mounting studs (8) and turn to right to secure.
2. Insert smokestack (2) through flue support bracket (6) and over elbow (7).
3. Install screw (3), nut (4), and washer (5), onto flue support bracket (6).
4. Install upper length of smokestack (2) to lower section.
5. Slide guard assembly (1) over smokestack (2).

To install the exhaust duct onto the M-85 Water Heater, proceed as follows:

Slide new exhaust duct (9) onto the exhaust collar (10).

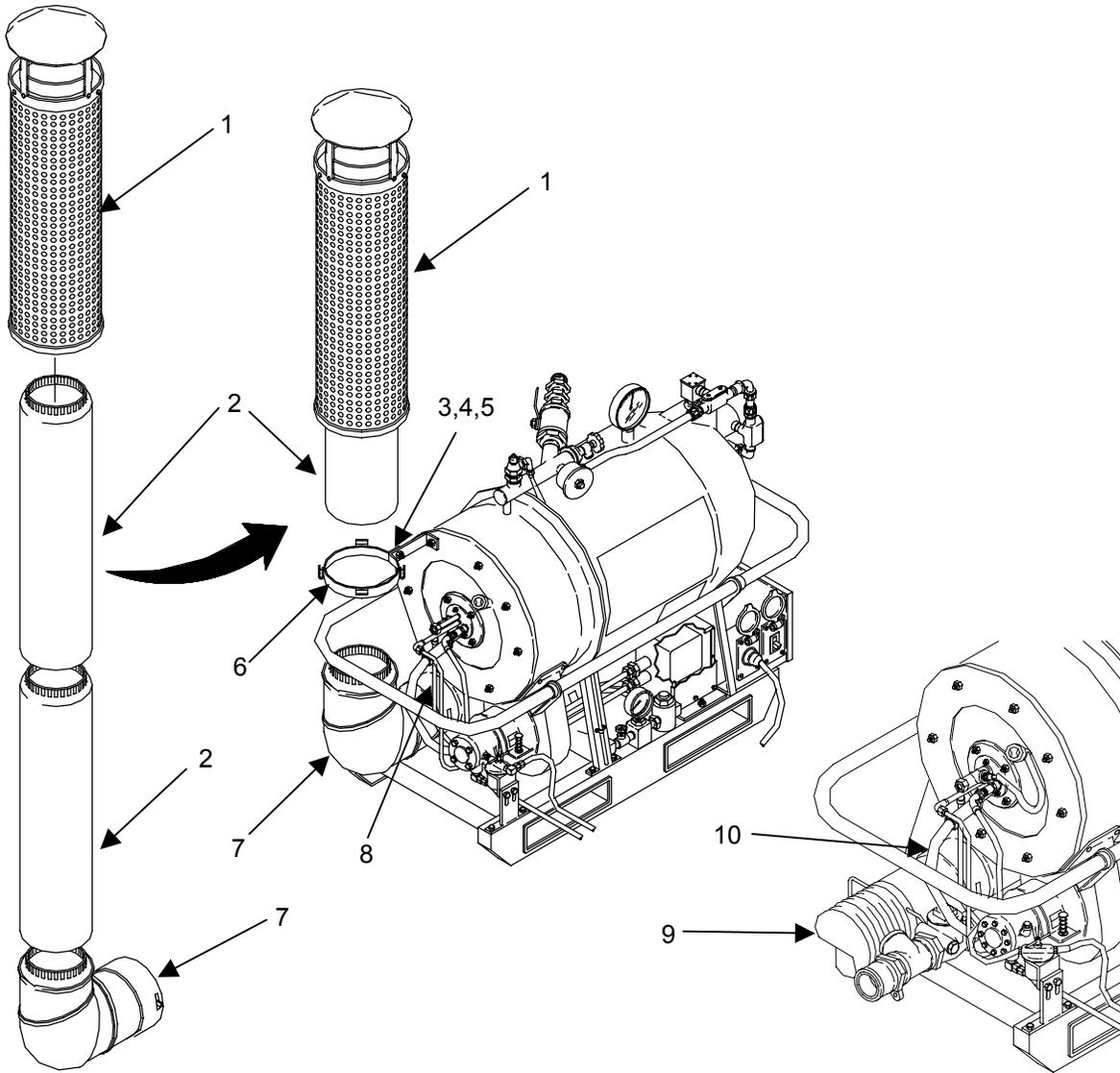

END OF WORK PACKAGE

UNIT MAINTENANCE
HEATER, WATER, LIQUID FUEL M-80 AND M-85
NSN 4520-01-162-0385 (M-80) 4520-01-237-3719 (M-85)
IGNITION TRANSFORMER AND IGNITION CABLE ASSEMBLIES
INSPECT, REMOVE, TEST, INSTALL

INITIAL SETUP:**Tools**

Tool Kit, General Mechanic's, Automotive (Item 3,
WP 0038 00)
Multimeter (Item 1, WP 0038 00)

Personnel Required

One

Materials/Parts

Cloth, Cleaning (Item 1, WP 0057 00)

Equipment Condition

Water heater shut down, cooled down, power
disconnected.

INSPECT

1. Inspect transformer assembly for physical damage, corrosion, and rust on transformer housing.
2. Inspect ignition cable assemblies for frayed insulation, damage to the connectors, or loose connections.
3. Replace a damaged or corroded transformer or frayed cable as necessary.

REMOVE**WARNING**

Lethal voltage is present when the water heater is connected to a power source. Disconnect the water heater from its power source before performing the following procedures. Be careful not to touch electrical connections. Serious injuries or death to personnel from electrocution may result.

CAUTION

Two different transformers may be found on the M-80 and M-85 Water Heater. The original equipment 208 VAC, 3 Phase Model, or the retrofitted (also installed as original equipment in later models) 110 VAC Model. Both types are removed/installed in similar manner, however the transformers are not interchangeable. Installation of the wrong transformer will result in an inoperative Water Heater and a damaged transformer.

To remove the ignition transformer, proceed as follows:

1. Turn power switch **(1)** to **OFF** and disconnect power cord from the receptacle **(2)** on the control box.
2. Disconnect two ignition cable assemblies **(3)** from the transformer box **(4)**.
3. Remove and retain six screws **(5)** securing transformer cover **(6)** to box **(4)**.
4. Remove cover **(6)** from transformer box **(4)**.
5. Disconnect transformer leads **(7)** in transformer box **(4)**.
6. Disconnect the power supply conduit **(8)** from the transformer box **(4)**.
7. Remove two nuts **(9)** and washers **(10)** from studs **(11)** on skid and remove transformer from skid.
8. Remove screws holding transformer in box **(4)** and remove transformer.

To remove the transformer cable assemblies, proceed as follows:

1. At the burner head assembly, loosen connector **(12)** on ignition cable **(3)** and disengage cable.
2. Remove cables from water heater.

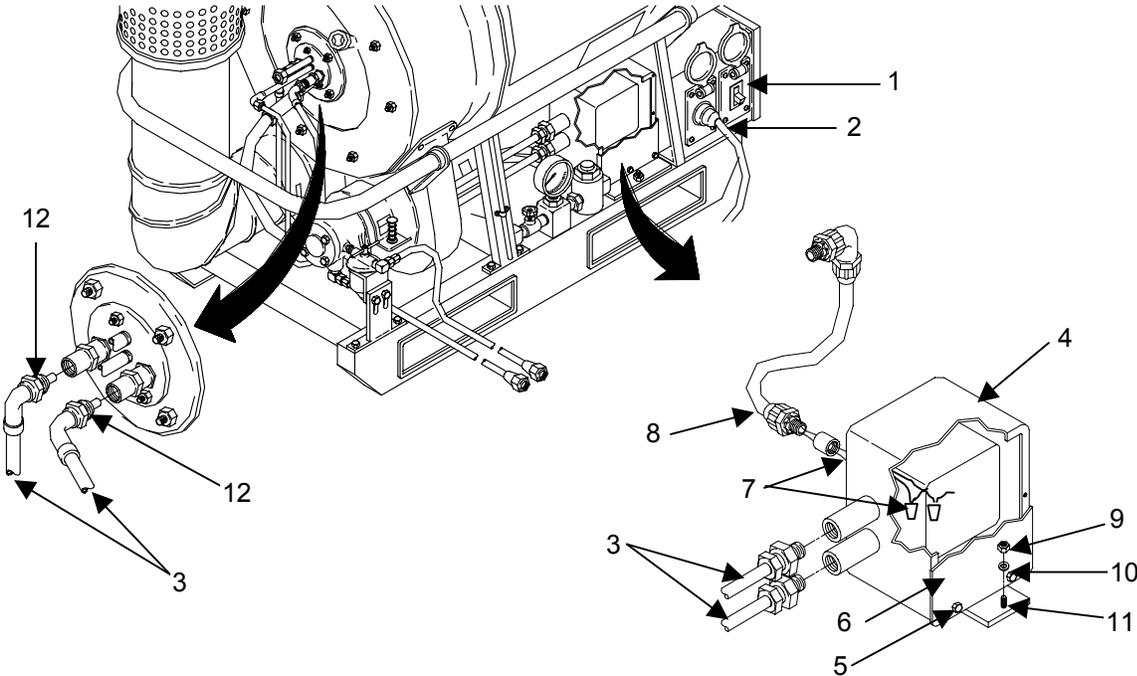

TEST**NOTE**

Test procedures for the two different transformers are the same, with the exception that the resistance specifications are different as specified in the test instructions below.

To test a transformer proceed as follows:

1. Using a multimeter set to measure ohms, check resistance between the two primary wires **(1)**. Resistance should be approximately 2—7 ohms. A reading of 0 ohms or infinity indicates a defective transformer.
2. Check resistance between one primary wire **(1)** and transformer housing **(2)**. Resistance should be infinity (indicating an open circuit). Any reading, other than infinity, indicates a defective transformer.
3. Repeat steps 1 and 2 on secondary side. Resistance should be higher.

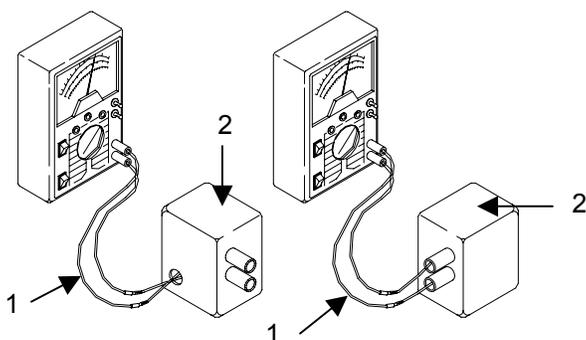

Type Transformer	Primary Ohms	Secondary Ohms
110 VAC	2-7	15-50
208 VAC	1-5	15-50

4. If test indicates defective transformer, replace it.

INSTALL

NOTE

All defective 208 VAC, 3 phase ignition transformers must be converted to 110 VAC, single phase operation. Order MODIFICATION KIT, ELECTRIC POWER to install the 110 VAC transformer.

To install a new transformer and ignition cable assembly, proceed as follows:

1. Remove and retain six screws from new transformer to remove cover (1).
2. Install the conduit (2) onto the transformer box (3).
3. Position the transformer box (3) onto the studs (4) on the skid and secure it with two nuts (5) and lock washers (6).
4. Using two wire nuts, connect the transformer leads (7) in the box (3).
5. Making sure that the ignition cable terminals (8) make good contact with the transformer terminals (9) install the ignition cables (10).
6. Install the cover (1) onto the transformer box (3) using six retained screws.
7. Reinstall the ignition cables (10) onto the spark plugs on the burner head assembly and tighten connectors (11).
8. Reconnect power cord (12) to the receptacle on the control box, the turn power switch (13) on control box to **ON**.

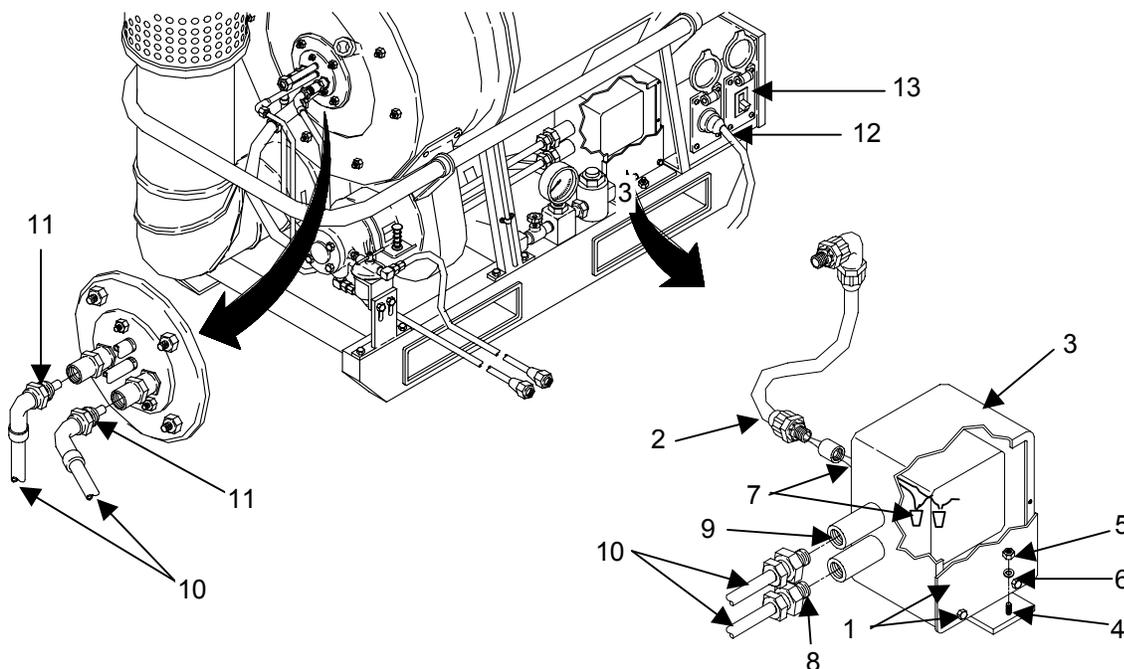

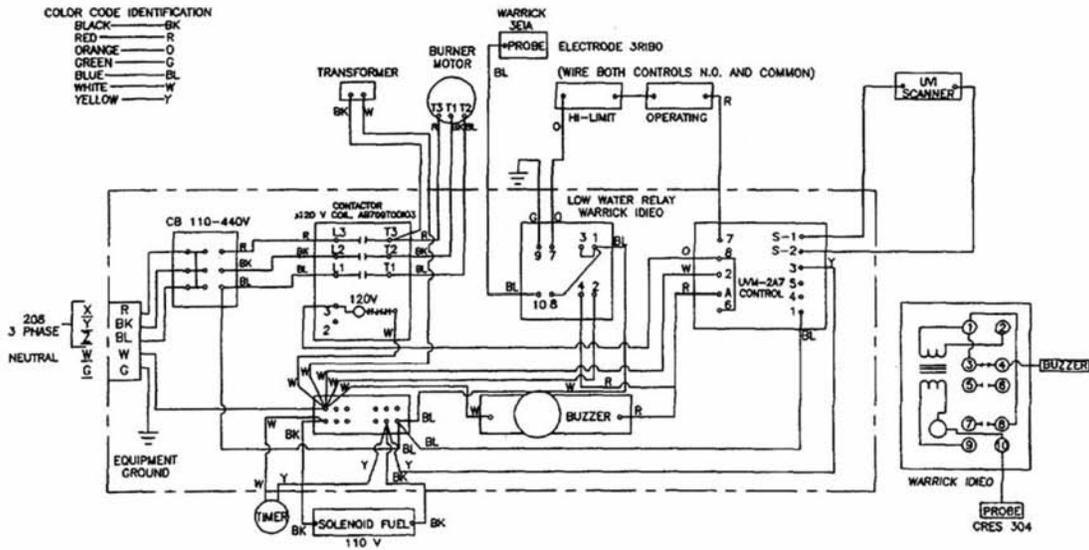

Electrical Schematic for M-80/M-85 with 110 VAC transformer

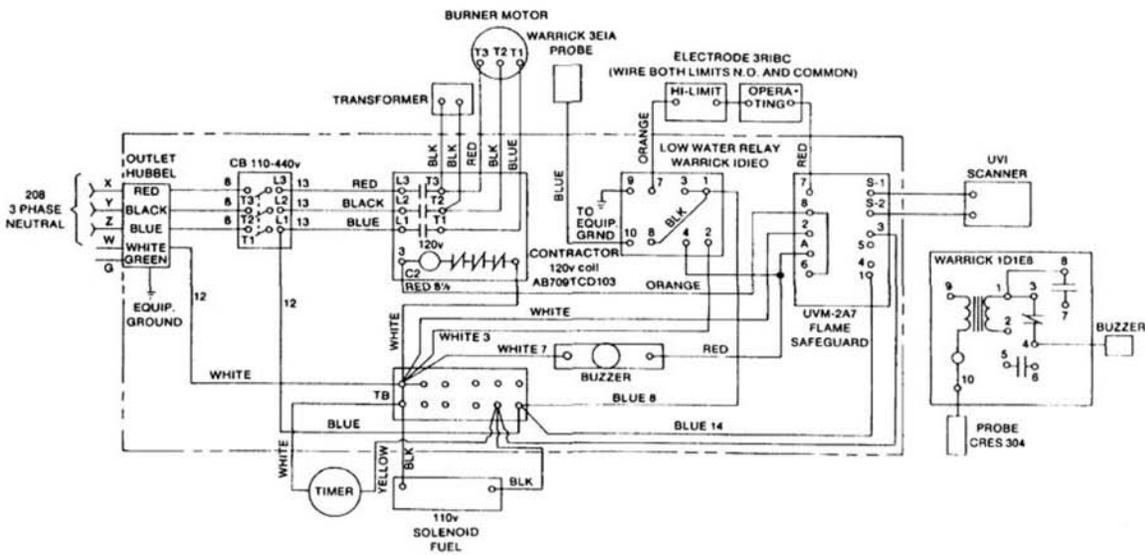

Electrical Schematic for M-80/M-85 with 208 VAC transformer

END OF WORK PACKAGE

UNIT MAINTENANCE
HEATER, WATER, LIQUID FUEL M-80 AND M-85
NSN 4520-01-162-0385 (M-80) 4520-01-237-3719 (M-85)
FUEL FILTER ASSEMBLY
INSPECT, REMOVE, REPAIR, INSTALL

INITIAL SETUP:**Tools**

Tool Kit, General Mechanic's, Automotive (Item 3, WP 0038 00)

Personnel Required

One

Materials/Parts

Solvent, Dry Cleaning (Item 12, WP 0057 00)
Cloth, Cleaning (Item 1, WP 0057 00)

Equipment Condition

Water heater shut down, cooled down, power disconnected.

INSPECT

1. Inspect the fuel filter for damage, leaks, and missing parts.
2. Inspect security of mounting hardware and attached fuel hoses. Replace a damaged fuel filter.

REMOVE

WARNING

When removing fuel filter components, avoid fuel spills. Serious injuries from igniting fuel or explosion could result.

To remove the fuel filter on the M-80 Water Heater, proceed as follows:

1. Disconnect the fuel supply line **(1)** from the elbow **(2)** on the fuel pump. Elevate the disconnected hose end so fuel will drain back into container. Rest hose on container.
2. Remove elbow **(2)**.
3. Remove two capscrews **(3)**, two nuts **(4)**, two flat washers **(5)**, and two star washers **(6)** from top of the fuel filter.
4. Lower rivet **(7)** on air band to lowest position to clear fuel filter **(8)**.
5. Remove two nuts **(9)**, lockwashers **(10)**, screws **(11)**, flat washers **(12)**, and brace **(13)** from mounting bracket **(14)**.
6. Remove mounting bracket **(14)**.
7. Unscrew fuel filter **(8)** from nipple **(15)** by turning counterclockwise.

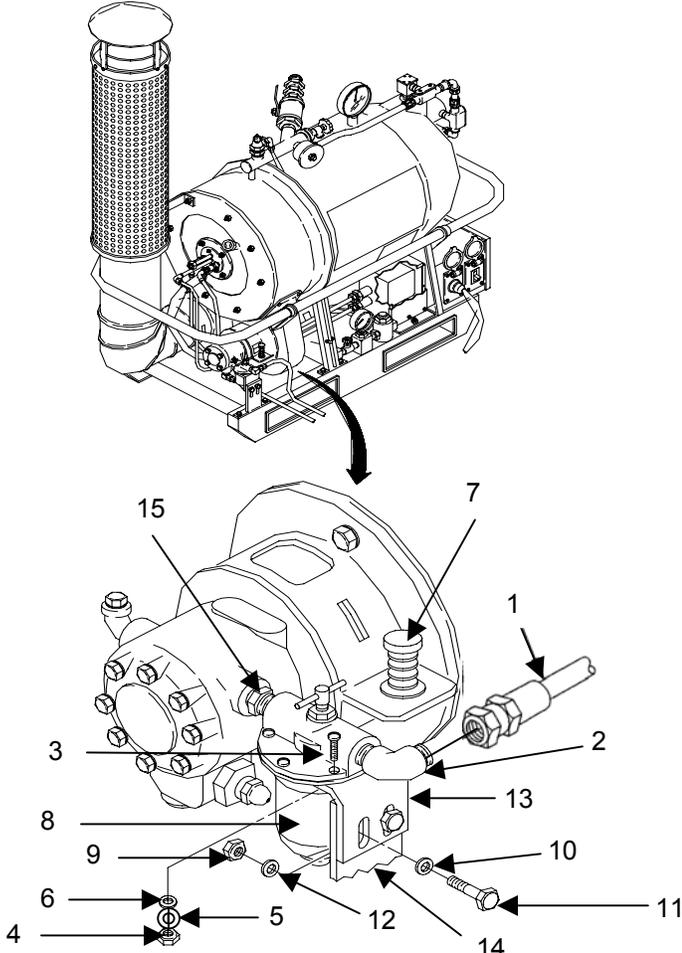

To remove the fuel filter on the M-85 Water Heater, proceed as follows:

1. Disconnect both hoses (1) from nipples (2).
2. Remove two nuts (3), lock washers (4), screws (5), flat washers (6), and brace (7) from mounting bracket (8).
3. Remove nipples (2) from fuel filter (9).

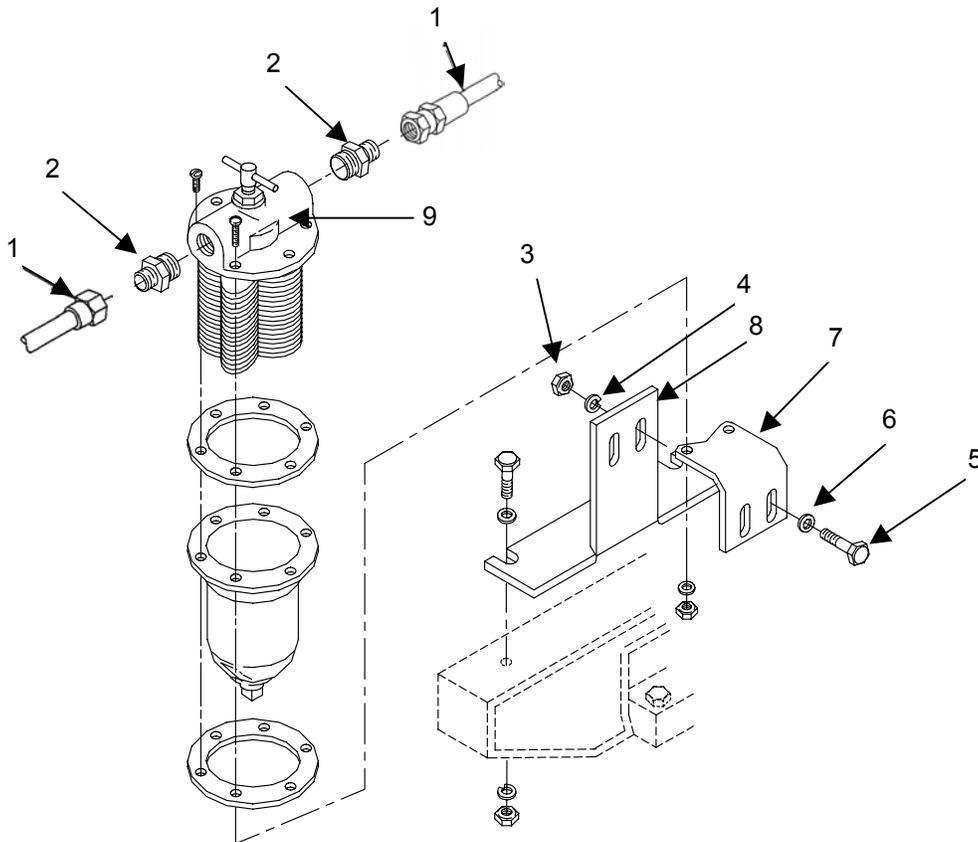

REPAIR

Repair the fuel filter by cleaning filter components and installing a new gasket.

1. Remove two nuts **(1)** two lock washers **(2)** screws **(3)** and brace **(4)** from the fuel filter head **(5)**.
2. Remove four screws **(6)** securing plate **(7)**, filter bowl **(8)**, and gasket **(9)**, from fuel filter head **(5)**.

**WARNING**

Dry-cleaning solvent, P-D-680, Type III is potentially dangerous. Avoid repeated or prolonged breathing of vapors and skin contact with liquid. Use only in well ventilated area. Failure to comply may result in serious injury or death.

**WARNING**

Do not use near open flame, arcing equipment, or other ignition sources. Failure to comply may result in serious injury or death.

3. Clean all parts in dry cleaning solvent.
4. Install a new gasket **(9)**, filter bowl **(8)**, and plate **(7)**. Secure to fuel filter head **(5)** with four screws **(6)**.
5. Install the brace **(4)** on fuel filter head **(5)** and secure with two screws **(3)**, lock washers **(2)**, and nuts **(4)**.

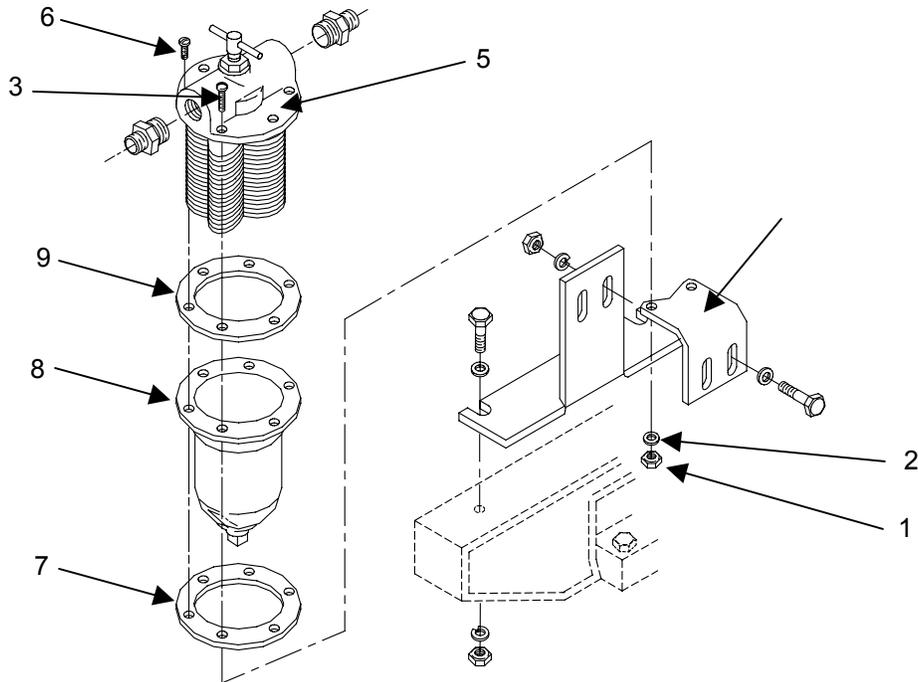

INSTALL

To install the fuel filter on the M-80 Water Heater, proceed as follows:

1. Join filter **(1)** to nipple **(2)** and turn clockwise until tight.
2. Install fuel filter brace **(3)** to mounting bracket **(4)** using two screws **(5)**, two lock washers **(6)**, two flat washers **(7)** and two nuts **(8)**.
3. Install elbow **(9)**.
4. Connect fuel line **(10)**.

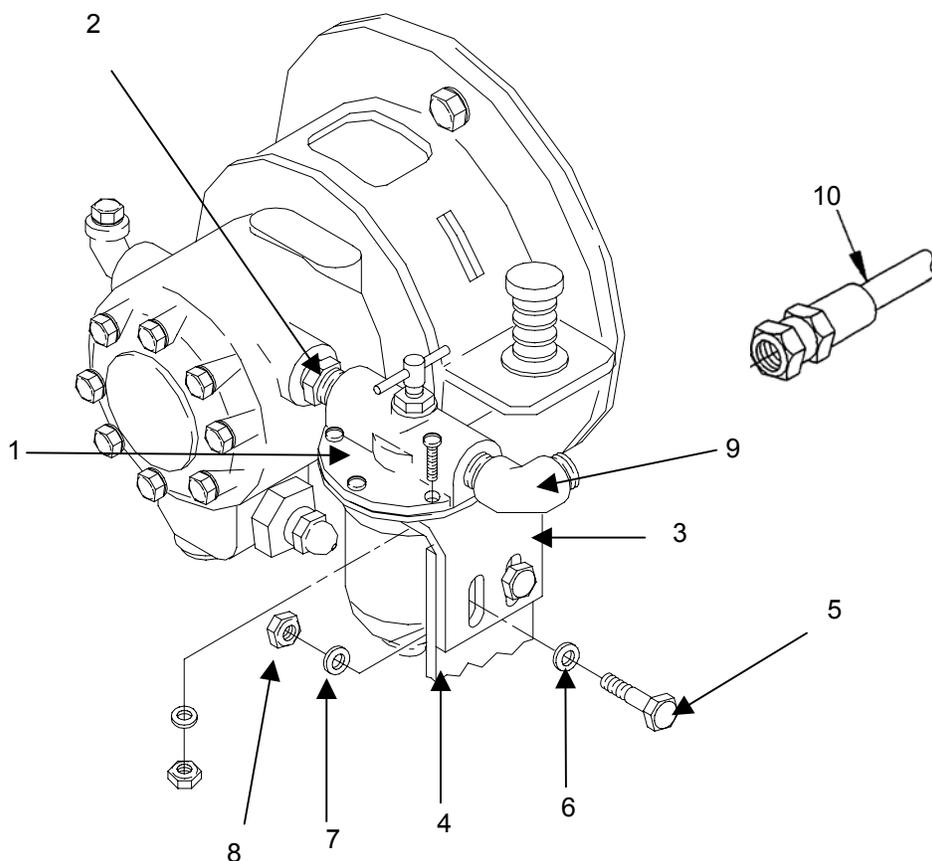

To install the fuel filter on the M-85 Water Heater, proceed as follows:

1. Install nipples **(1)** in filter **(2)**. Inlet side takes large nipple and outlet side takes small nipple.
2. Position fuel filter **(3)** on fuel filter brace **(4)** and secure with two screws **(5)**, flat washers **(6)**, and nuts **(7)**.
3. Install fuel filter brace **(4)** to mounting bracket **(8)** using two screws **(9)**, two flat washers **(10)**, two lockwashers **(11)**, and two nuts **(12)**.
4. Connect both fuel hoses **(13)** to the nipples **(1)** on the fuel filter **(2)**.

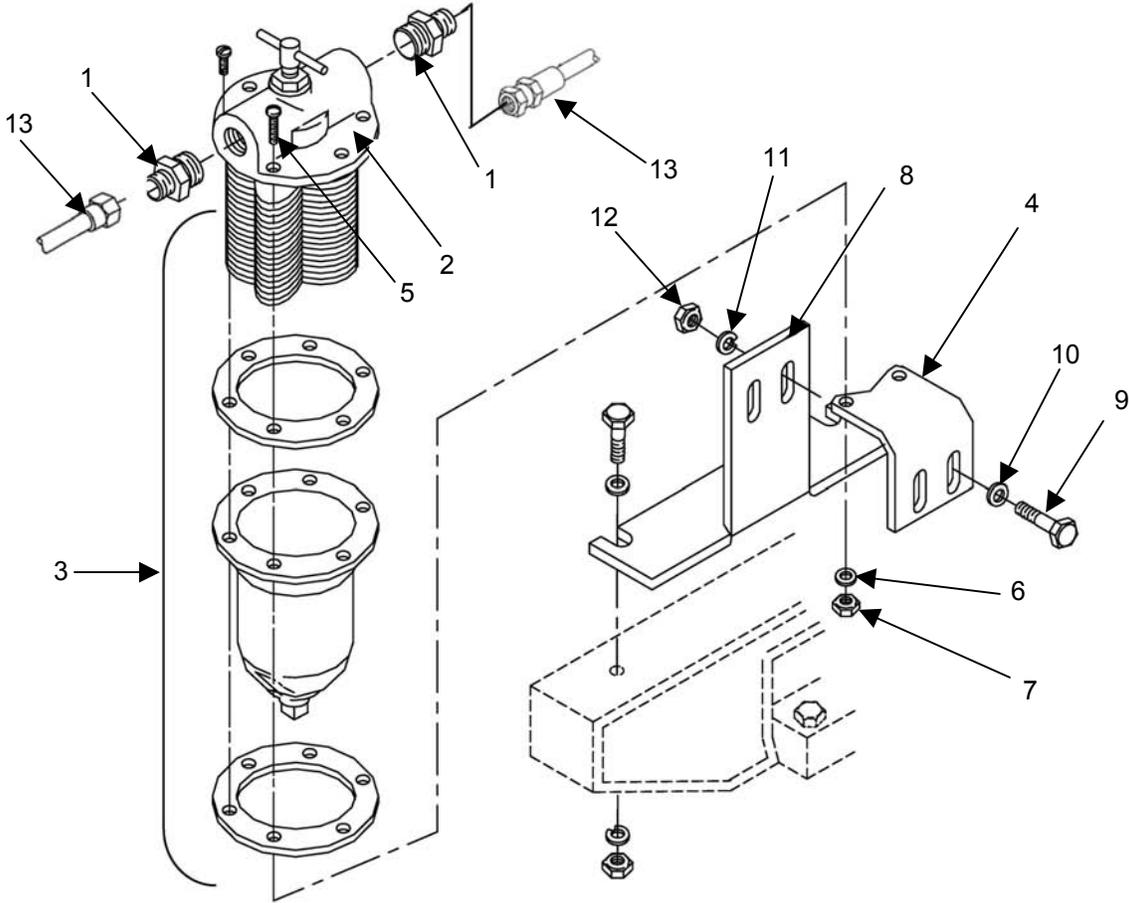

END OF WORK PACKAGE

UNIT MAINTENANCE
HEATER, WATER, LIQUID FUEL M-80 AND M-85
NSN 4520-01-162-0385 (M-80) 4520-01-237-3719 (M-85)
FUEL PUMP ASSEMBLY
SERVICE, INSPECT, ADJUST

INITIAL SETUP:**Tools**

Tool Kit, General Mechanic's, Automotive (Item 1, WP 0038 00)

Personnel Required

One

Materials/Parts

Cloth, Cleaning (Item 1, WP 0057 00)

Equipment Condition

Water heater shut down, cooled down, power disconnected.

SERVICE**WARNING**

When removing fuel pump components, avoid fuel spills. Igniting fuel or explosion could result in serious injury or death to personnel.

Service the fuel pump by removing dirt and clogs from the fuel strainer as follows:

1. Remove eight screws **(1)** from fuel pump cover **(2)**.
2. Remove cover **(2)** and gasket **(3)** from fuel pump **(4)**.
3. Grasp strainer **(5)** by its handle and pull it out of the pump **(4)** housing.
4. Clean or unclog strainer **(5)** as necessary.
5. Push clean or new strainer **(5)** back into the pump **(4)** housing.
6. Position gasket **(3)** and cover **(2)** onto fuel pump **(4)**, and install eight screws **(1)**.

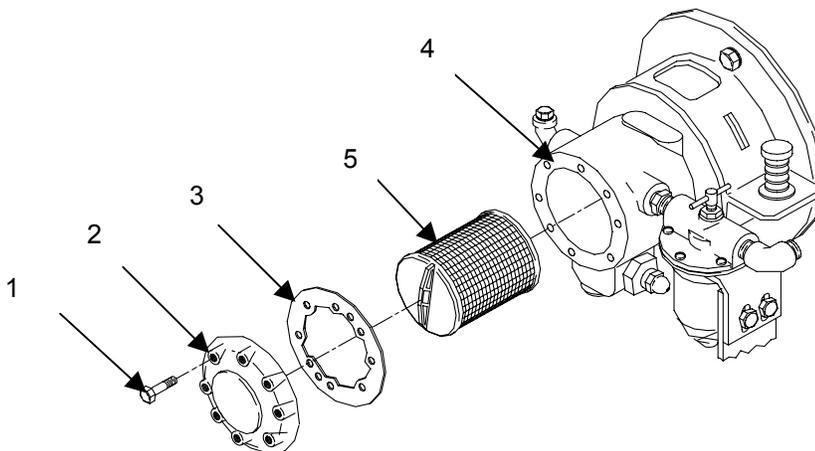

INSPECT

1. Inspect the fuel pump for damage to housing.
2. Check for damaged threads on fuel filter and elbow connections.

NOTE

To perform the following procedures, reconnect the water heater to a power source and start it as described in work package 0005 00.

ADJUST

1. With water heater in operation, open the air shutter **(1)** fully.
2. Remove the cap nut **(2)** from the fuel pressure adjustment screw.
3. Adjust the fuel pressure for the following elevations:

<u>Elevation (ft)</u>	<u>Pressure (psi)</u>
0-2500	125
2500-4000	115
Over 4000	100

4. Install the cap nut **(2)** on the fuel pressure adjustment screw.

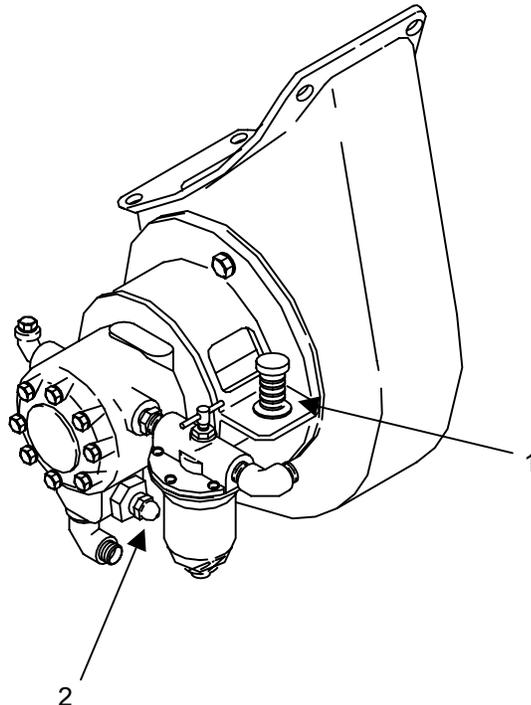
**END OF WORK PACKAGE**

UNIT MAINTENANCE
HEATER, WATER, LIQUID FUEL M-80 AND M-85
NSN 4520-01-162-0385 (M-80) 4520-01-237-3719 (M-85)
WATER VESSEL AND SKID ASSEMBLY
INSPECT, REPAIR

INITIAL SETUP:**Tools**

Tool Kit, General Mechanic's, Automotive (Item 3, WP 0038 00)

Personnel Required

One

Materials/Parts

Cloth, Cleaning (Item 1, WP 0057 00)
 Paint (Item 8, WP 0057 00)

Equipment Condition

Water heater shut off, cooled down.
 Power switch off, cable disconnected.

INSPECT

Inspect the water vessel and skid assemblies as described below. Notify direct support maintenance of any broken welds or other damage that cannot be corrected by cleaning, painting, or tightening of bolts.

1. Inspect smoke box cover gasket **(1)** for breaks, burns or other damage.
2. Inspect water vessel **(2)** for dents, breaks, cracks, leaks or areas of peeling paint. Check weld spots **(3)** for breaks.

REPAIR

WARNING

Do not paint in confined areas. Apply primer and paint in a well-ventilated area and wear respirator protection.

NOTE

Do not paint hose fittings on the upper and lower manifold, glass, or decals.

1. Repair the water vessel and skid assembly by cleaning and priming exposed surfaces. Then apply one coat of paint per FED-STD595.
2. Tighten mounting bolts **(4)** on skid assembly if necessary.

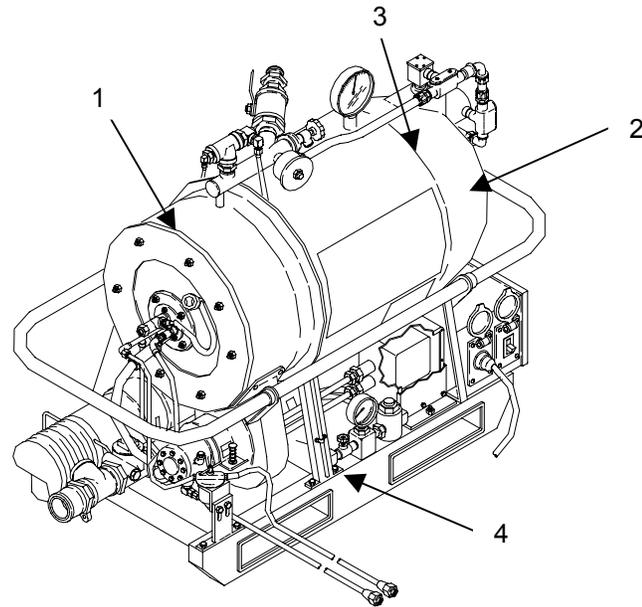
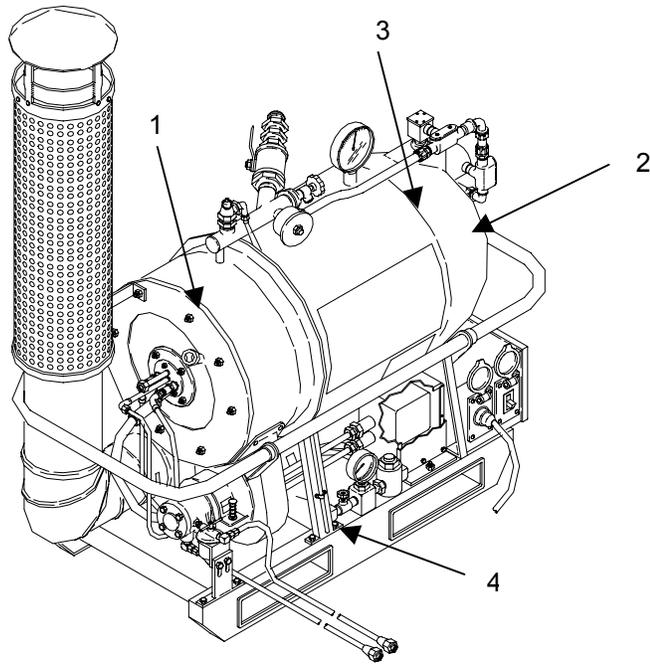

END OF WORK PACKAGE

UNIT MAINTENANCE
HEATER, WATER, LIQUID FUEL M-80 AND M-85
NSN 4520-01-162-0385 (M-80) 4520-01-237-3719
UPPER AND LOWER MANIFOLD ASSEMBLY
INSPECT, REMOVE, REPAIR, INSTALL

INITIAL SETUP:**Tools**

Tool Kit, General Mechanic's, Automotive (Item 3, WP 0038 00)
Tool Kit, Organizational, Common No. 1 (Item 4, WP 0038 00)

Personnel Required

One

Materials/Parts

Cloth, Cleaning (Item 1, WP 0057 00)
Sealer (Item 10, WP 0057 00)

Equipment Condition

Water heater shut off, cooled down.
Power switch off, power cable disconnected.

INSPECT

Inspect the upper and lower manifold assemblies for leaks, corrosion, damage, or loose components.

REMOVE

WARNING

Hot water under pressure may be present in the water heater. Do not attempt to work on the plumbing until the water heater is cooled down.

1. Unscrew coupling **(1)** from bushing **(2)** on the M-80, or the ball valve **(3)** on the M-85.
2. Unscrew ball valve **(3)** from the upper manifold **(4)**.
3. Unscrew vent valve **(5)** and coupling **(6)** from upper manifold **(4)**.
4. Unscrew overflow tube fitting **(7)** and clamp **(8)** from elbow **(9)**. Remove overflow tube **(10)**.
5. (M-80) Unscrew elbow **(9)** from upper bushing **(11)**.
6. (M-80) Unscrew upper bushing **(11)** from relief valve **(12)**.
7. (M-80) Unscrew relief valve **(12)** from lower bushing **(13)**.
8. (M-85) Unscrew connector **(14)** from elbow **(15)**.
9. (M-85) Unscrew elbow **(15)** from bushing **(16)**.
10. (M-85) Unscrew relief valve **(17)** from tee **(18)**.

11. (M-85) Unscrew tee **(18)** from bushing **(19)**.
12. Unscrew bushing **(19)** from upper manifold **(4)**.
13. Unscrew coupling **(20)** from lower manifold **(21)**.

REPAIR

Repair the manifold assemblies by removing rust or corrosion and tightening components to eliminate leaks. Replace any components that cannot be repaired.

INSTALL

NOTE

When installing threaded fittings, coat threads with sealer.

1. (M-80) Install lower bushing **(13)** into upper manifold **(4)**.
2. (M-80) Install relief valve **(12)** into lower bushing **(13)**.
3. (M-80) Install upper bushing **(11)** into relief valve **(12)**.
4. (M-80) Install elbow **(9)** into upper bushing **(11)**.
5. (M-80) Install overflow tube **(10)** by attaching fitting **(7)** to elbow **(9)** and install clamp **(8)**.
6. (M-85) Install bushing **(19)** into upper manifold **(4)**.
7. (M-85) Install tee **(18)** into bushing **(19)**.
8. (M-85) Install relief valve **(17)** into tee **(18)** and elbow **(9)** into relief valve **(17)**.
9. (M-85) Install bushing **(16)** and elbow **(15)** onto tee **(18)**.
10. (M-85) Install connector **(14)** onto elbow **(15)**.
11. (M-85) Install overflow tube **(10)** by attaching fitting **(7)** to elbow **(9)** and install clamp **(8)**.
12. Install vent valve **(5)** and coupling **(6)** onto upper manifold **(4)**.
13. Install ball valve **(3)** onto upper manifold **(4)**.
14. (M-80) Install bushing **(2)** onto ball valve **(3)** and coupling **(1)** onto bushing **(2)**.
15. (M-85) Install coupling **(1)** onto ball valve **(3)**.

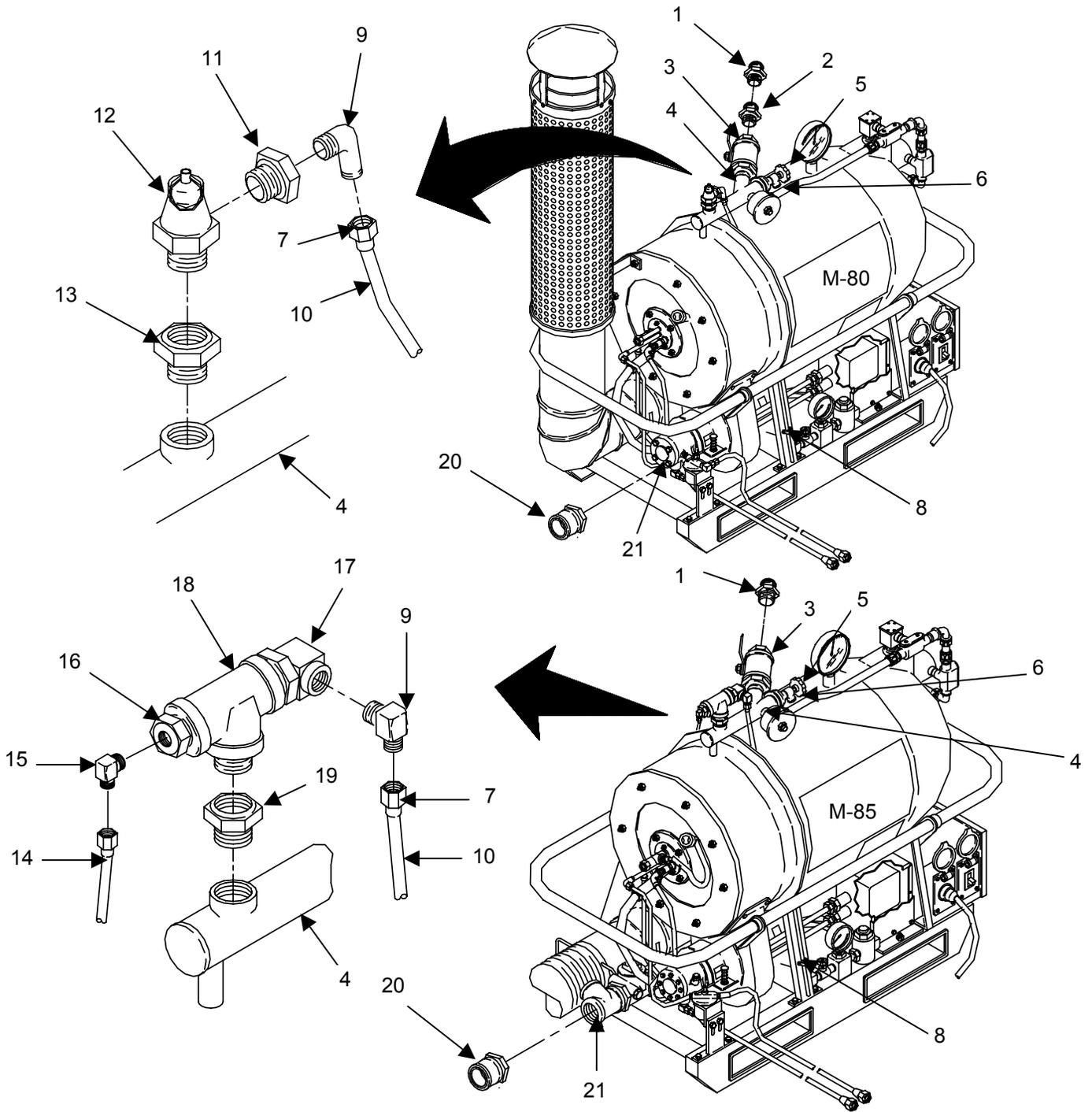

END OF WORK PACKAGE

UNIT MAINTENANCE
HEATER, WATER, LIQUID FUEL M-80 AND M-85
NSN 4520-01-162-0385 (M-80) 4520-01-237-3719 (M-85)
DRUM FILL ADAPTER ASSEMBLY, TYPE II
INSPECT, REPAIR

INITIAL SETUP:**Tools**

Tool Kit, General Mechanic's, Automotive
(Item 3, WP 0038 00)

Personnel Required

One

Materials/Parts

Cloth, Cleaning (Item 1, WP 0057 00)
Sealer (Item 10, WP 0057 00)

Equipment Condition

Water heater shut off, cooled down.
Power switch off, power cable disconnected

INSPECT

1. Inspect the drum fill adapter assembly for damage, leaks, and improperly assembled, loose or missing components.
2. If necessary, disassemble adapter and replace or reassemble components properly.

REPAIR

Repair the drum fill adapter assembly by replacing defective parts during reassembly.

Disassemble the drum fill adapter assembly**WARNING**

When disassembling the drum fill adapter components, avoid fuel spills. Serious injuries from igniting fuel or explosion could result.

1. Remove extension adapter **(1)** from pipe connector **(2)** by turning counterclockwise.
2. Remove pipe connector **(2)** by turning counterclockwise.
3. Remove two male connectors **(3)** by turning counterclockwise and remove caps **(4)** or fuel lines from connectors.
4. Remove two screws **(5)**, four washers **(6)**, block **(7)**, and adapter pipe **(8)**.
5. Remove adapter pipe **(8)** from block **(7)** by turning counterclockwise.
6. Remove cover **(9)** from nipple **(10)** by turning counterclockwise.

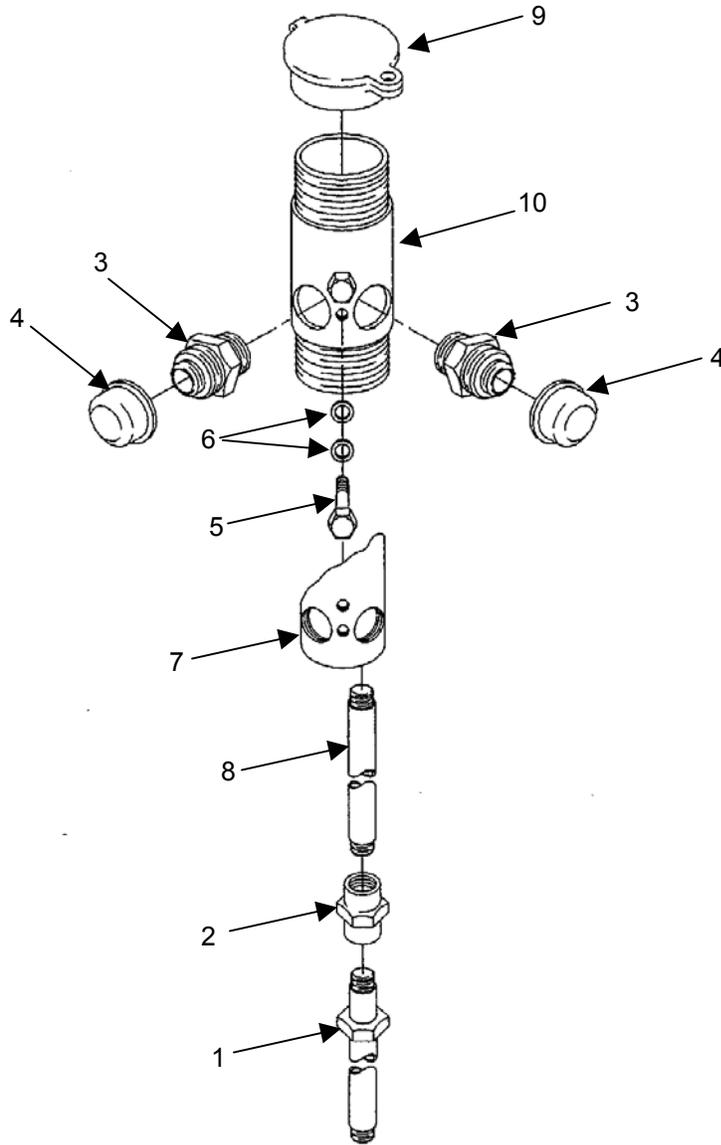

Assemble the drum fill adapter assembly**NOTE**

When installing threaded fittings, coat threads with sealer.

1. Attach cover (9) to nipple (10) by turning clockwise.
2. Attach double male pipe to supply side.
3. Install adapter pipe (8) in block (7) by turning clockwise.
4. Install block (7) and adapter pipe (8) in nipple (10) using two screws (5) and four washers (6).
5. Install pipe connector (2) on adapter pipe (8) and extension adapter (1) on pipe connector (2)
6. Install two male connectors (3) in nipple (10) by turning clockwise. Replace fuel lines.

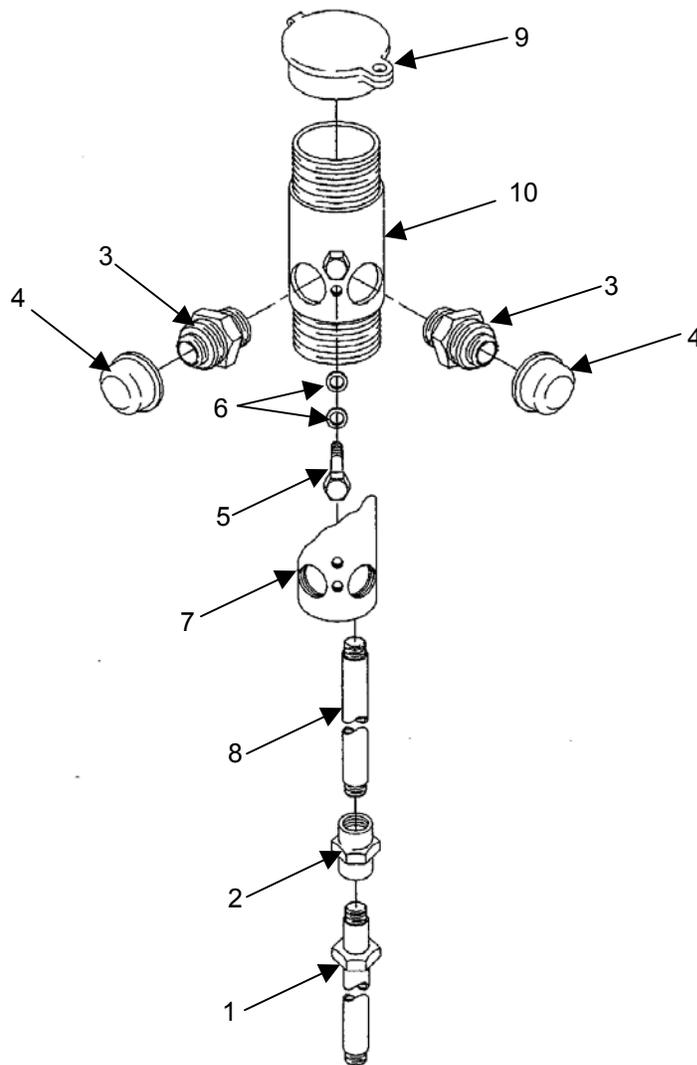

END OF WORK PACKAGE

UNIT MAINTENANCE
HEATER, WATER, LIQUID FUEL M-80 AND M-85
NSN 4520-01-162-0385 (M-80) 4520-01-237-3719 (M-85)
UV AND IR SCANNER AND FLAME CONTROL SAFEGUARD ASSEMBLY
TEST, REMOVE, REPAIR, INSTALL

INITIAL SETUP:**Tools**

Tool Kit, Electronic Equipment (Item 3, WP 0038 00)
 Multimeter (Item 1, WP 0038 00)

Personnel Required

One

Materials/Parts

Cloth, Cleaning (Item 1, WP 0057 00)
 Tag (Item 13, WP 0057 00)

Equipment Condition

Water heater set up for operation and cool.

TEST

1. Initiate start-up in accordance with WP 0005 00. Ensure that water supply (water pump or commercial source) is on. Make sure all air is completely bled from the water heater. Failure to bleed all air from the water heater will activate the low water switch, sound the buzzer and prevent the unit from starting. Turn switch **(5)** ON.
2. If ignition occurs momentarily or the audible alarm sounds, continue to step 6. Wait approximately 30 seconds for burner motor to start. If burner motor does not start, turn switch **(5)** OFF and continue to the next step. If burner motor starts and ignition continues, resume normal operation.

NOTE

If the alarm sounds, an ignition failure is indicated.

3. Open control box cover **(4)** and reset burner motor overload **(7)** by pushing button **(3)**. Check for normal operation by turning switch **(5)** ON. If overload continues to trip, test the motor contactor and overload operation as described in the next two steps. If overload is not tripped, continue to step 6.

**WARNING**

High voltage is present on this equipment.
 Death or serious injury to personnel may result.

CAUTION

Ensure that power is **OFF** before making continuity check. Damage to test equipment could result. Isolate any electrical components before starting continuity check.

4. Turn switch **(5)** OFF, turn electrical power OFF and disconnect power cable. Use a multimeter to test resistance from each input to output terminal of the motor starter **(6)**. Meter should indicate an open circuit (Ω) at each set of terminals. Manually actuate the motor contactor by pushing in contacts. Meter should indicate continuity (0 ohms) at each set of terminals. If contact reads a high resistance or is open, replace the motor starter as described in WP0035 00. Test resistance of contactor pull-in coil. Meter should indicate a low resistance value. If coil reads infinity (Ω) or zero (0) ohms, replace the motor starter.

5. Reset motor overload (7) by pushing button (3) and test for continuity on each input to output terminal of the overload. If no continuity is read, replace the heaters or motor starter as described in WP 0035 00. If motor starter test indicates a good contactor and overload and overload continues to trip, test the burner motor as described in WP 0031 00.

Determine Type of Flame Control and Scanner

NOTE

The water heater has either an **Ultraviolet (UV) flame safeguard control and UV flame scanner** or **Infrared (IR) flame safeguard control and IR flame scanner**.

The Micro M Series **IR flame safeguard control** has light indicators to indicate the operating status of the flame control. If the water heater is equipped with an (µM) IR flame safeguard control, continue to step 14.

6. The **UV flame safeguard control** only has a reset button on the cover. If the water heater is equipped with an UV flame safeguard control (M Series, UVM-2), test the flame control system as follows:
 7. Does burner ignition occur momentarily and then go out, continue to step 12. If burner will not ignite at all, open water heater control cover (4). If an ignition failure has occurred or a safety shutdown, manual reset of the flame control is required by pressing the reset button (2) on the flame control (1). If burner motor does not start after reset of lockout, continue to next step.

NOTE

In the event of ignition failure or safety shutdown, the flame control will lockout and must be reset by pushing the button on front of the flame control. Electrical power must be on for reset of flame control lockout.

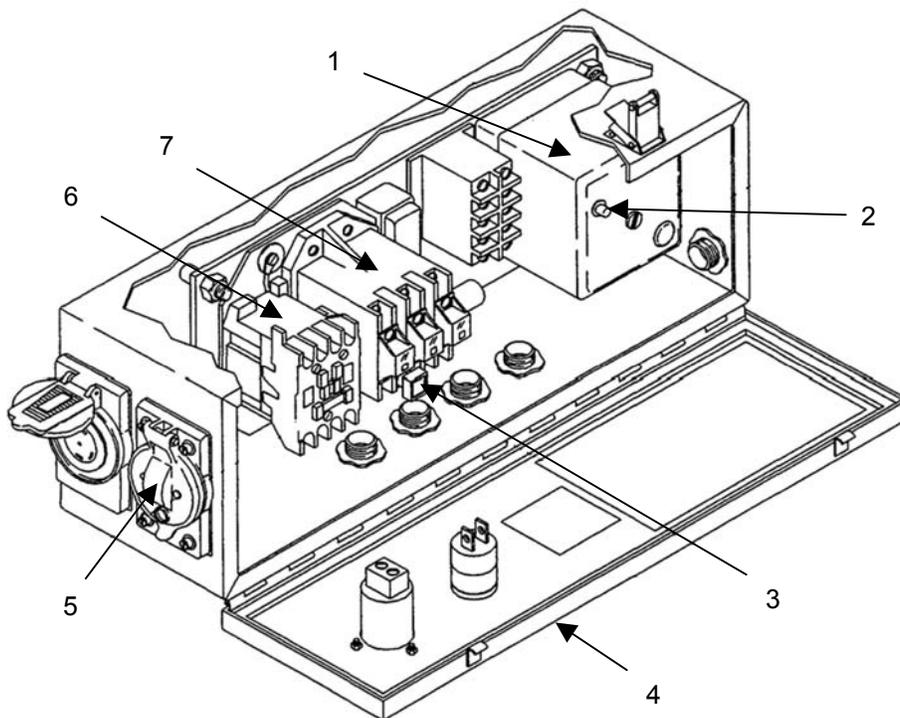

Water Heater Control Box

WARNING

Remove all jewelry before working on the water heater. Jewelry can catch on equipment and cause injury or may short across an electrical circuit and cause severe burns or electrical shock and death. Use extreme caution when performing any test with power on. Electrical current can cause severe injury or death.

8. Loosen screw (5) on flame control cover (6) and remove cover from chassis (4). Use voltage meter and test for 120 VAC at test points, TP 1 and TP 2 on the flame control chassis. See second illustration following for test point location on control chassis. If voltage is as indicated, continue to step 13. If voltage is not present, continue to the next step.

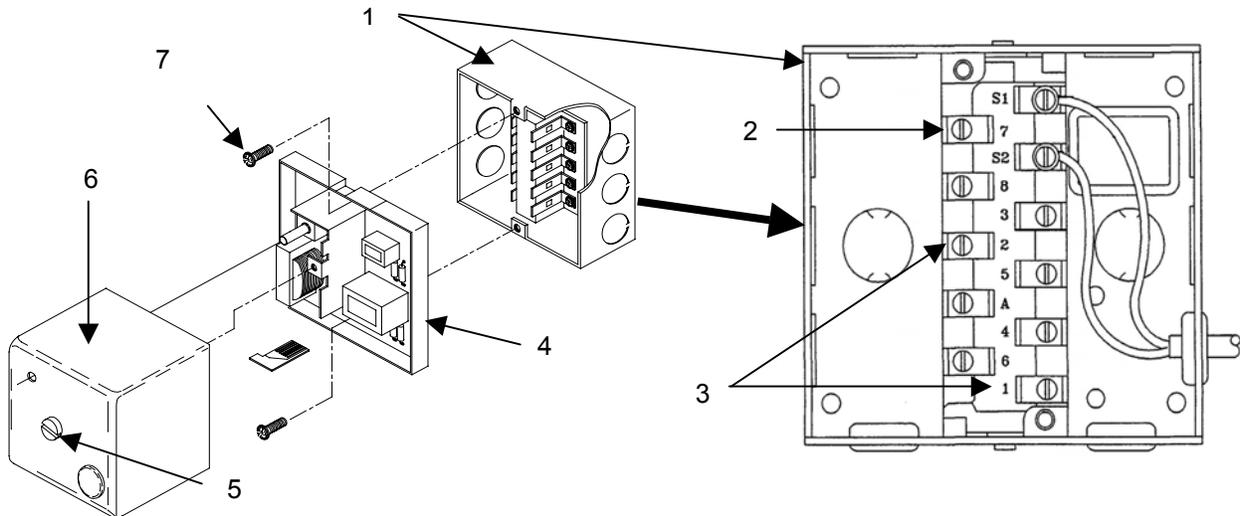
**UV Flame Safeguard Control and Terminal Box**

9. Turn OFF power switch. Remove two screws (7) and control chassis (4) from terminal box (1).
10. Turn ON power switch and test for 120 VAC across terminals # 1 and # 2 (neutral) of base terminal board (3) in terminal box. If voltage is not present, turn off water heater, disconnect power source and test the control box and power switch as described in WP 0035 00. If voltage is present continue to next step.

NOTE

Confirm that there is no measurable voltage present between chassis ground and terminal # 2 (neutral). Correct by tightening all electrical power connections if voltage is read.

11. Test for 120 VAC on terminal # 7 on base terminal board (2) in terminal box (1). If voltage is not present on # 7, turn OFF power switch and power source. Check the operating and high limit control in Work Package 0029 00 and low water relay in WP 0035 00. If voltage at terminal # 7 is as indicated, continue to step 13.

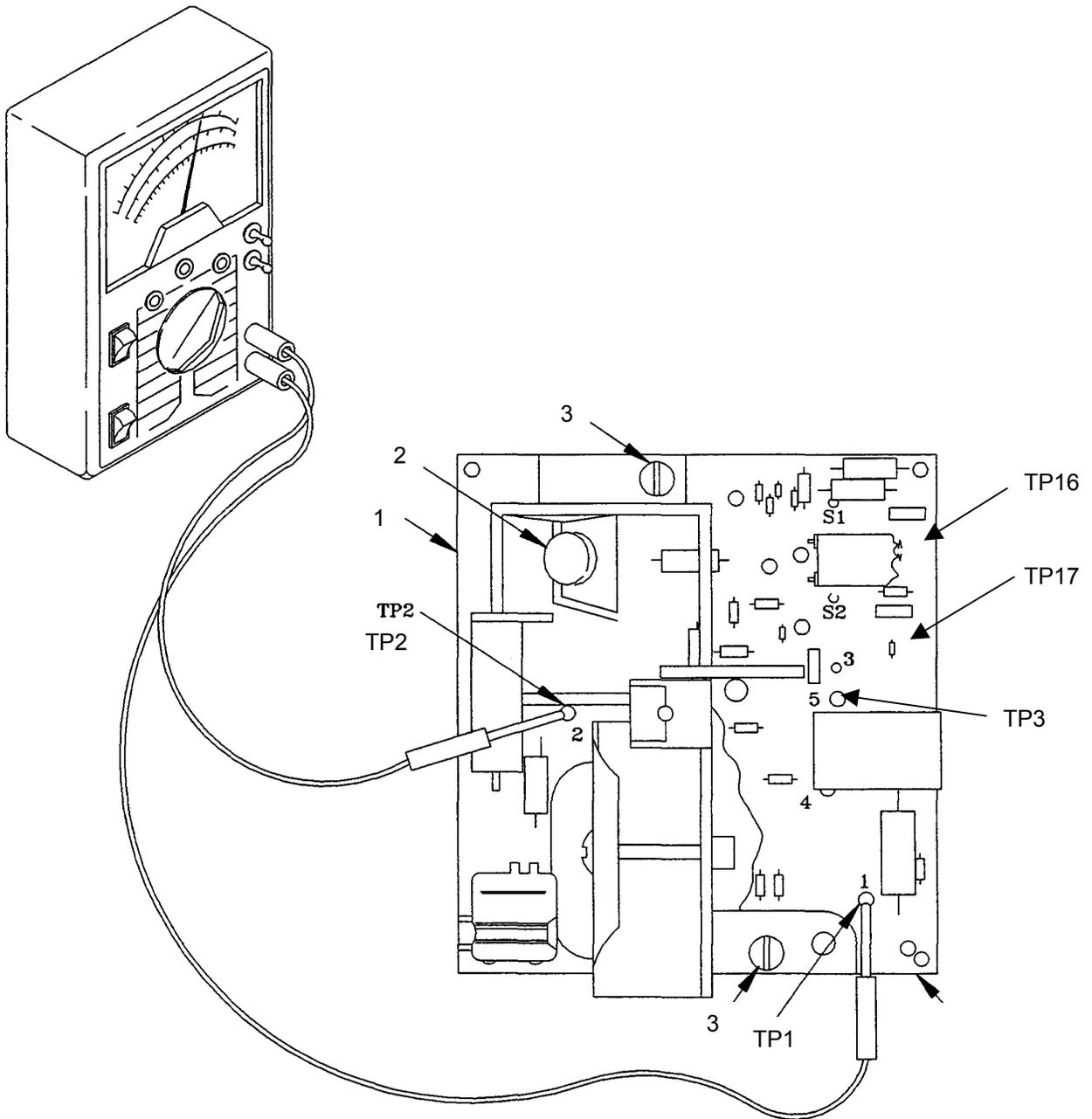

UV Flame Safeguard Control Chassis

Test Point Locations

12. If it has been determined that burner ignition takes place momentarily but system shuts down immediately after ignition, test as follows:
 - a. Turn power switch OFF. Loosen center screw of flame control cover and remove from chassis (1). Set voltage meter to read DC volts, insert BLACK (-) meter test lead at test point TP 16 and RED (+) meter test lead in TP 17. See illustration following for test point location on control chassis. If reading are as indicated and control still does not function continue to next step.

NOTE

Ensure the flame scanner is clean and the sight tube is free of obstructions. Remove flame scanner from the burner assembly sight tube. Clean the flame sensor window with a soft cloth, removing all oil and soot. Flame must be even and steady, adjust air shutter, if necessary.

- b. Turn power switch ON. Push flame control reset (2), if ignition does not occur. Meter should read 4.0 to 6.0 VDC when UV flame control detects flame in burner. Let the burner shutdown. Voltage should be zero (0) VDC when no flame is present in burner. If readings are not as indicated, install a new IR flame safeguard control and IR flame scanner as described under REMOVE and INSTALL of this work package. If reading are as indicated and control still does not function continue to the next step.

NOTE

If a defective UV flame safeguard control or UV flame scanner is installed on the water heater, it must be replaced with an Infrared (IR) flame safeguard controller and IR scanner.

NOTE

UV and IR components (control and scanner) are not interchangeable. Do not mix these flame control system components.

NOTE

If any component of the UV flame safeguard control system is found to be defective, order MODIFICATION KIT, ELECTRIC POWER to convert the system to IR flame control. Kit contains all parts needed to convert system to IR flame control. After conversion, individual IR flame control repair parts may be separately ordered.

13. If it has been determined that burner ignition does not occur after pressing flame control reset button **(2)**, set voltage meter for AC operation. Test for 120 VAC at test points, TP 2 and TP 3 on control chassis **(1)** after pressing reset button **(2)**. If no voltage is indicated, turn power OFF, install a new IR flame safeguard control and IR flame scanner as described under REMOVE and INSTALL of this work package.

NOTE

If a defective UV flame safeguard control or UV flame scanner is installed on the water heater, it must be replaced with an Infrared (IR) flame safeguard controller and IR scanner.

NOTE

UV and IR components (control and scanner) are not interchangeable. Do not mix these control systems.

NOTE

If any component of the UV flame safeguard control system is found to be defective, order MODIFICATION KIT, ELECTRIC POWER to convert the system to IR control. Kit contains all parts needed to convert system to IR flame control. After conversion, individual IR flame control repair parts may be separately ordered.

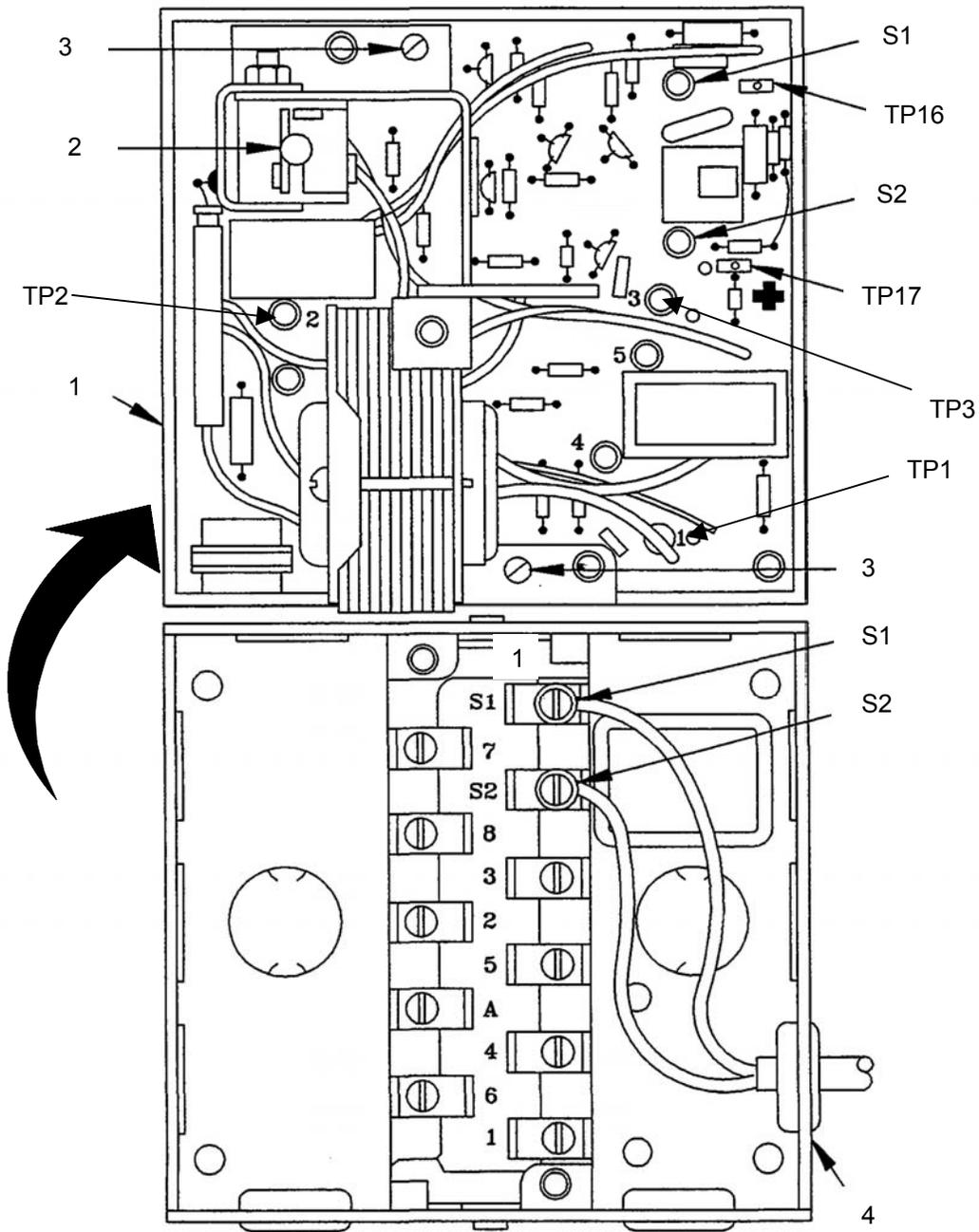

UV Flame Safeguard Control and Terminal Box

(Flame Control Chassis (1) is removed from terminal box (4) for illustration only)

14. If the water heater is equipped with an **IR flame safeguard control** (μ M), test the flame control system as follows:
15. The flame safeguard control has five (5) indicators that indicate the status of the control. They are also used as an aid to troubleshoot the control.
 - a. **OPERATING CONTROL** – illuminated whenever there is a call for heat.
 - b. **INTERLOCK** – illuminated when power is output to burner motor contactor.
 - c. **PTFI** – illuminated only during initial start up when control is allowing flame to stabilize.
 - d. **FLAME** – illuminated only when a flame is detected.
 - e. **ALARM** – flashes when an alarm condition is indicated, buzzer sounds.
16. Does burner ignition occur momentarily and then go out, continue to step 20. If burner motor will not start, open the control panel. If an ignition failure has occurred or a safety shutdown, manual reset of the flame control is required by pressing the reset button **(10)** on the flame control. If burner does not start after reset of lockout, continue to next step. If burner motor starts and ignition continues, resume normal operation.

NOTE

In the event of ignition failure or safety shutdown, the flame control will lockout and must be reset by pushing the button on front of the flame control. Electrical power must be on for flame control reset.

17. Observe the **OPERATING CONTROL**, **INTRLCK** and **PTFI** indicators **(4)** on the programmer module **(3)**. If all three are on, there is a blown fuse **(8)** on the chassis **(2)** by the transformer. Turn OFF power switch, power source and disconnect power cable. Refer to the **REPAIR** section of this Work Package to replace fuse. A blown fuse may be an indication of a problem with the fuel solenoid valve. After fuse replacement, check for normal system operation. If normal operation is not obtained, continue to the next step.
18. If all indicators are blinking and the **ALARM** indicator is on steady, replace the programmer module **(3)** as described under **REMOVE** and **INSTALL** of this work package. Replace module and check for normal operation.

NOTE

The IR flame control programmer module dipswitch settings will be stored after approximately 8 hours of operation. Changing the switch setting after 8 hours of operation will cause the programmer to malfunction and the control become inoperable. Once stored, the settings cannot be altered.

19. Observe the status indicators **(4)**. A lit **OPERATING CONTROL** indicates that there is a call for heat. If the **OPERATING CONTROL** is on, continue to the next step. If the **OPERATING CONTROL** is not on, go to step 23.
20. Observe the **FLAME** indicator, it should not be on if flame is not present. Initiate start-up by pushing reset button **(10)** on front of the flame control. **PTFI** should illuminate for a few seconds until the flame stabilizes and the **FLAME** indicator will illuminate if a flame is detected by the control. Continue to the next step if not observed.

NOTE

Ensure the flame scanner is clean and the sight tube is free of obstructions. Remove flame scanner from the burner assembly sight tube. Clean the flame sensor window with a soft cloth, removing all oil and soot. Flame must be even and steady, adjust air shutter, if necessary.

21. Loosen center screw (6) on flame control cover (7) and remove cover from chassis (2). Set voltage meter to read DC volts, insert meter test leads into test jacks (9) on the amplifier module (11). RED (+) meter test lead into the top test jack and BLACK (-) test lead into the bottom test jack. A reading of 0 (zero) VDC should be obtained when no flame is present. Press reset button (10) on flame control to initiate a restart. Meter should read 4.0 VDC to 10 VDC when the control detects flame. Wildly fluctuating readings are an indication of an unstable flame or a bad flame sensor. Adjust burner flame, if necessary. Replace flame sensor as described under REMOVE and INSTALL of this work package if there is no reading or erratic. If there is no reading or it continues to be erratic, continue to the next step.

NOTE

As a quick test, substitute a known good amplifier module (11) before replacing the flame sensor. Check for indicated readings, if normal, removed amplifier is bad.

22. If the readings are not obtained after replacement of the flame sensor, replace the amplifier module (11) as described under REMOVE and INSTALL of this work package. Check for normal system operation in accordance with WP 0005 00.

NOTE

UV and IR components are not interchangeable. Do not mix these control system sensors.

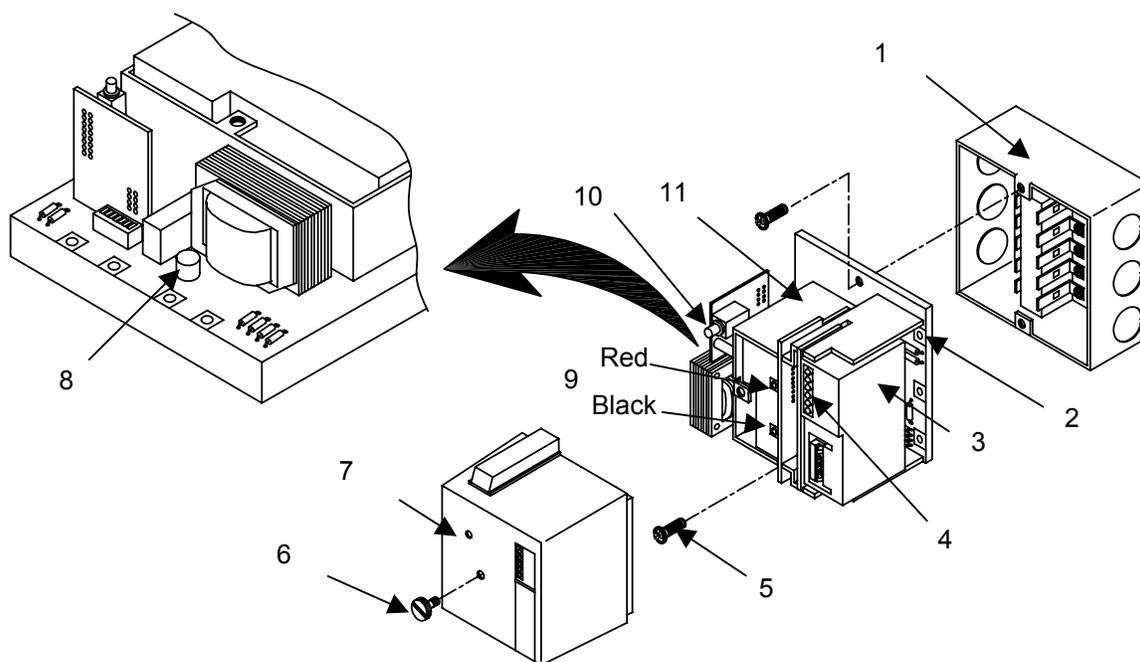

IR Flame Control and Terminal Box

23. Turn off power switch. Loosen screw **(6)** on cover **(7)** and remove from flame control chassis **(2)**. Amplifier **(11)** and programmer **(3)** module may be removed or left in place. Remove two screws **(5)** and control chassis **(2)** from terminal box **(1)**.
24. Turn on power switch and test for 120 VAC across terminals # 1 and # 2 (neutral) of base terminal board **(3)** in terminal box **(1)**. See illustration following for terminal location. If voltage is not present, turn off water heater, disconnect power source and test control box and power switch as described in work package 0035 00. If voltage is present continue to next step.

NOTE

Confirm that there is no measurable voltage present between ground and terminal # 2 (neutral). Correct by tightening all electrical connections if voltage is read.

25. Test for 120 VAC on terminal # 7 of base terminal board **(5)** in terminal box **(1)**. If voltage is not present on # 7, remove electrical power and test operating and high limit control in work package 0029 00 and low water relay in work package 0035 00. If voltage at terminals # 7 is as indicated, continue to next step.

NOTE

Some base terminal board inputs or outputs may be accessed on the IR flame controller chassis to the left of the transformer without removing chassis from the terminal box. Top to bottom terminals on the chassis are:

- 7 - Operating control input
- 8 - Contactor output
- 2 - Neutral
- A - Alarm output to buzzer
- 6 - Interlock, tied to terminal # 8

26. Additional tests that may determine if controller is bad. Turn OFF power and install flame control on terminal box as described in the INSTALL section of this Work Package. Turn ON power switch. Press flame control reset button. Test for 120 VAC on terminal # 3 of base terminal board **(2)** in terminal box **(1)**. Terminal # 3 is the flame control output to the fuel solenoid valve. Test for 120 VAC on terminal # 8 of base terminal board **(4)** in terminal box **(1)**. Terminal # 8 is the output for the burner contactor. If voltages are not as indicated, refer to the REPAIR section of this work package. Refer to the electrical schematic in WP 0004 00 or on the control panel door.

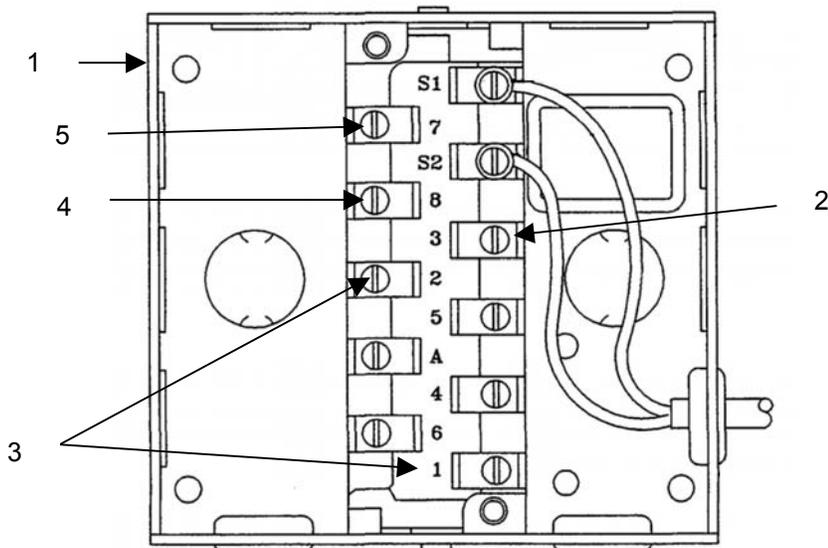

Terminal Box

REMOVE

Removal of an UV flame safeguard control:

Turn OFF water heater power switch, electrical power source and remove power cable. Loosen screw (1) and remove cover (2) from chassis (3). Remove two screws (4) and UV flame chassis (3) from terminal box (5).

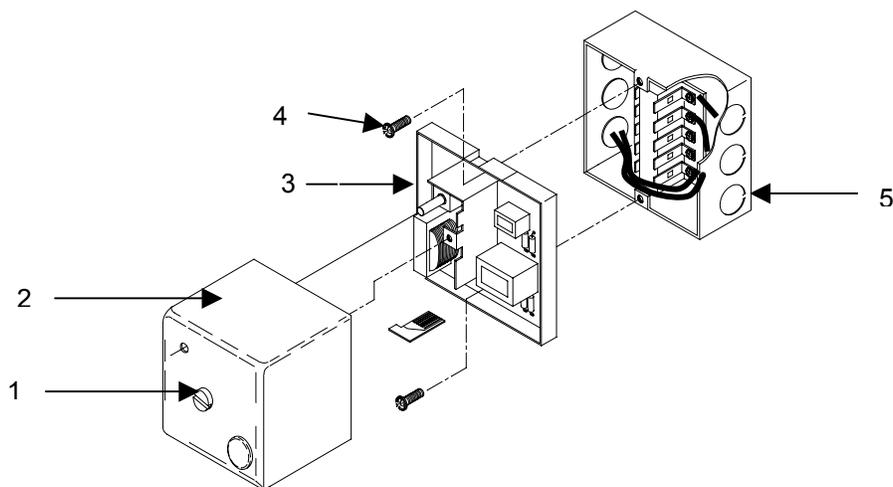

UV Flame Safeguard Control

To remove an **IR flame safeguard control**:

1. Turn OFF water heater power switch, power source and remove power cable.
2. Loosen screw **(1)** and remove cover **(2)** from chassis **(4)**. Amplifier **(3)** and programmer **(7)** module may be removed, if desired, or left in place. Handle modules only by the edges of the printed circuit board.
3. Remove two screws **(4)** and IR flame chassis **(6)** from terminal box **(5)**.

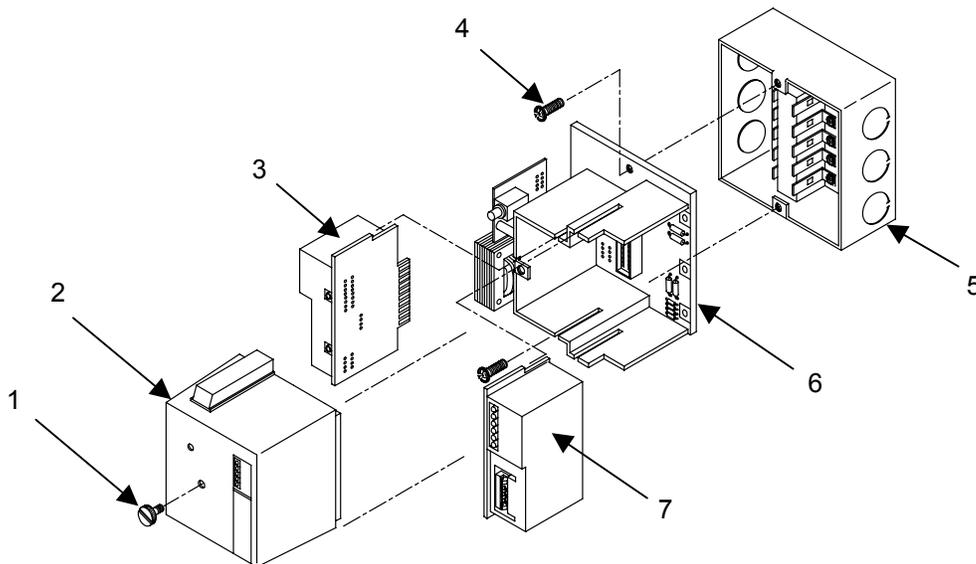

IR Flame Safeguard Control

To remove an **UV or IR flame scanner cable assembly**:

1. Turn OFF water heater power switch, power source and remove power cable. Open the water heater control box. Remove flame safeguard control **(2)** as described in REMOVE UV or IR flame control.
2. Remove flame scanner wires from S1 and S2 on terminal board **(6)** in terminal box **(1)**. Pull scanner cable from terminal box.
3. Unscrew and remove lock nut **(3)** and pull elbow **(4)** and wires out of water heater control box. Unscrew conduit nut **(5)** securing elbow to flexible conduit. Remove elbow from conduit and pull cable out of elbow. Retain elbow for later use.

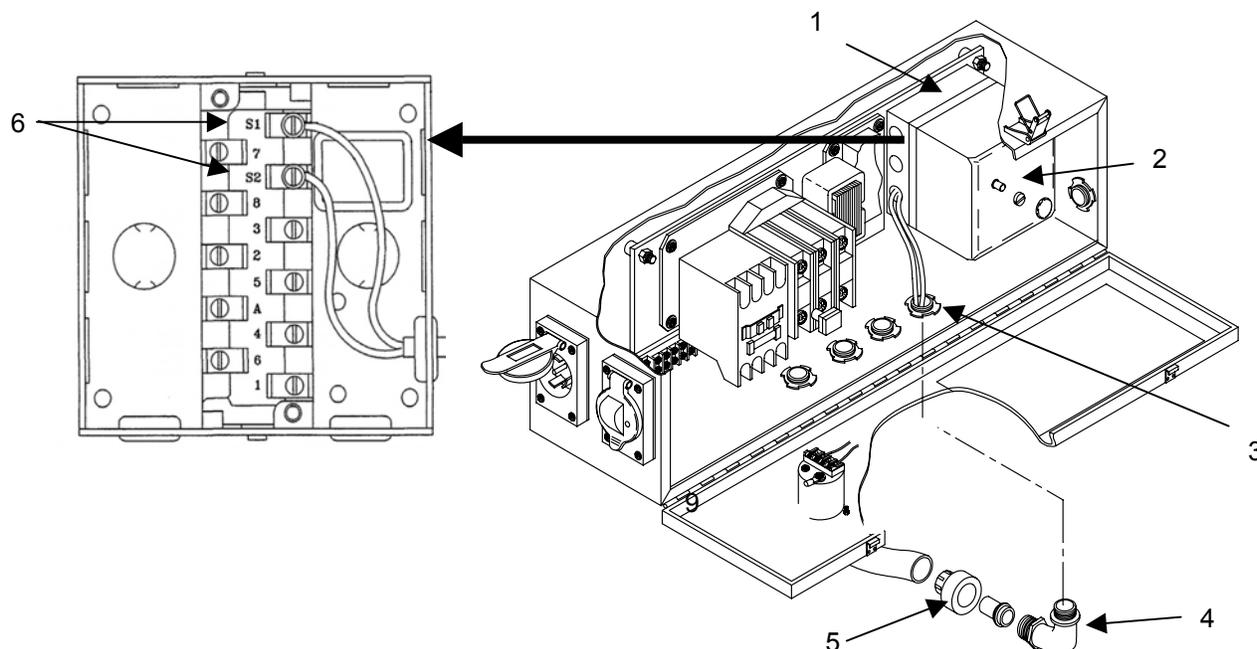

Water Heater Control Box

- Remove the flame scanner (4) from the burner head assembly (1) by unscrewing nut (5) from the burner sight tube or heat insulator (6) on sight tube. Remove heat insulator from sight tube, if installed.

NOTE

Ensure the burner sight tube is free of obstructions or build-up of soot. Clean if necessary.

- Electrical conduit (2) should be left in place under the water heater. Flame scanner (4) will be secured to the flexible conduit (2) by a connector or strain relief assembly. Twist the connector (3) from the end of the conduit and pull scanner cable out of the conduit.

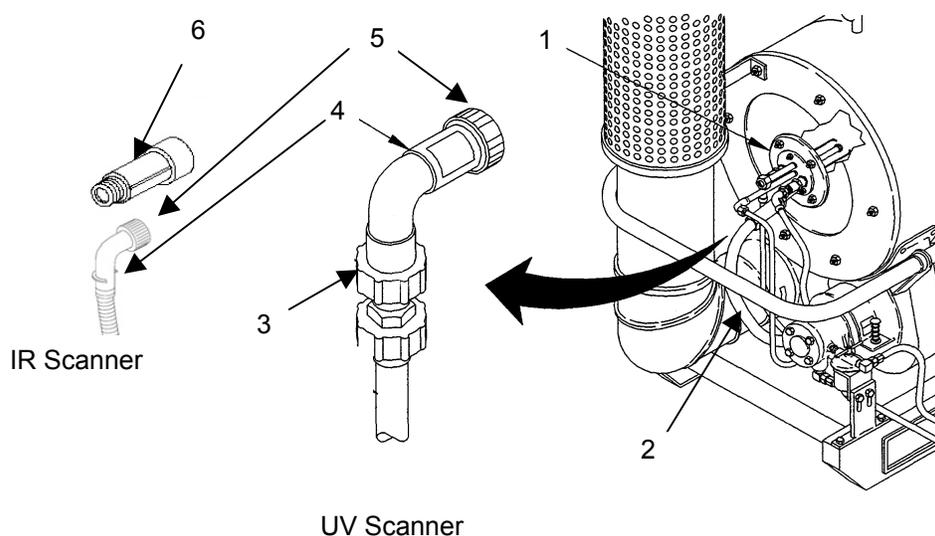

Burner Head Assembly

REPAIR

- A defective **UV flame safeguard control** is not repairable. Replace a defective UV flame control with an IR flame safeguard control and scanner as described under REMOVE and INSTALL of this work package.

NOTE

If any component of the UV flame safeguard control is found to be defective, order MODIFICATION KIT, ELECTRIC POWER to convert the system to IR control. Kit contains all parts needed to convert system to IR flame control. After conversion individual IR flame control repair parts may be separately ordered.

Repair a defective **IR flame safeguard control** as follows:

2. Observe the OPERATING CONTROL, INTRLCK and PTFI indicator of the IR flame safeguard control. If all three indicators are on, there is a blown fuse (7) on the circuit board below the transformer.
3. Turn OFF the power switch and loosen screw (5). Remove cover (6) from control chassis (3). Remove two screws (1) and the IR flame safeguard control from the terminal box (2). Use a small flat screwdriver to remove the fuse. Check the fuse (7), with a multimeter and replace if open. Replace with Fireye, part number 23-197 or Wickmann, part number 3732100041. A blown fuse may be an indication of a problem with the fuel solenoid or contactor circuit. Review the electrical schematic in WP 0004 00 or schematic on control panel door.

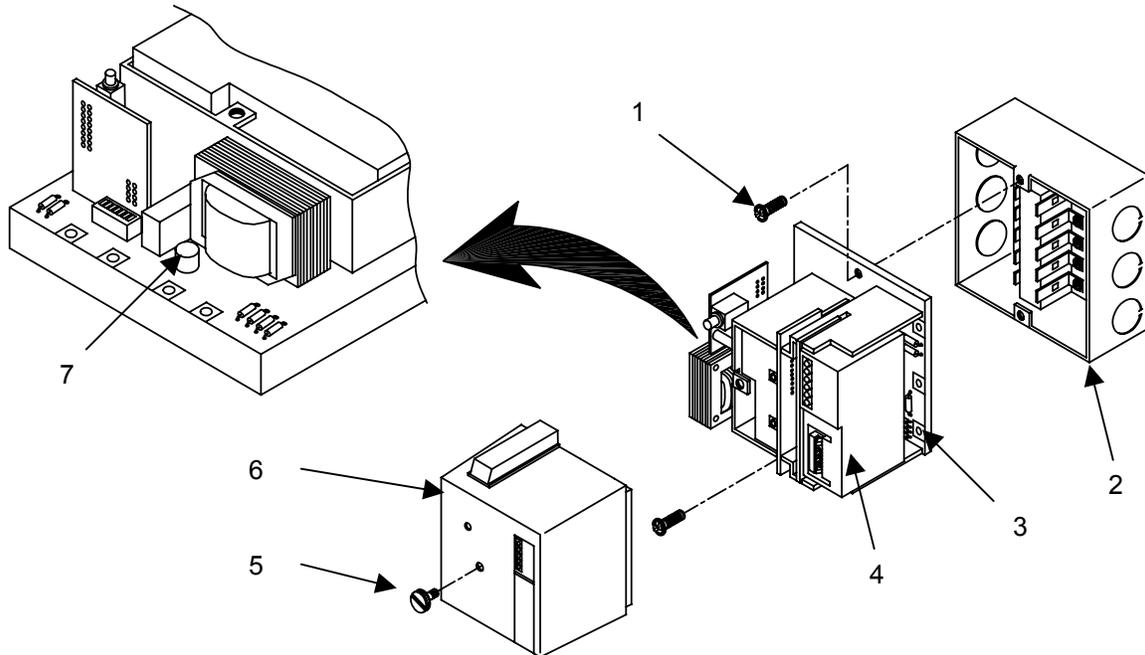

IR Flame Safeguard Control

4. After fuse replacement, install IR flame safeguard control (3) on terminal box (2) with two screws (1). Initiate start-up in accordance with WP 0005 00 and check for normal operation.
5. If all LED indicators are blinking and ALARM indicator is on steady then replace the programmer module (4) as described under REMOVE and INSTALL of this work package. Replace module and check for normal operation.
6. Replace chassis (3) if amplifier and programmer replacement does not repair flame control.

INSTALL

Install an **IR flame scanner and cable assembly** as follows.

NOTE

If any component of the UV flame safeguard control is found to be defective, order MODIFICATION KIT, ELECTRIC POWER to convert the system to IR flame safeguard control. Kit contains all parts needed to convert system to IR flame control. After conversion individual IR flame control repair parts may be separately ordered.

NOTE

UV and IR components (control and scanner) are not interchangeable.
Do not mix these control system sensors.

1. Install strain relief adapter on IR flame scanner as follows. Strain relief may have already been installed on flexible conduit if IR flame control scanner is installed on water heater.
2. Disassemble the strain relief adapter by removing outer shell **(1)** from strain relief body **(5)**. Remove black plastic disk **(2)** and compression bushing **(4)** from strain relief body **(5)**.
3. Remove snap ring **(3)** from IR flame scanner neck groove **(8)**.
4. Remove bushing **(6)** from end of scanner cable where wires extend from cable and secure for later use. Push the scanner cable **(6)** through the outer shell **(1)** and black plastic disk **(2)** until they are past the snap ring groove **(8)** on the scanner neck **(9)**.
5. Fasten snap ring **(3)** in place in scanner neck groove **(8)**.
6. Feed flexible conduit through compression bushing **(4)** and strain relief body **(5)**. Tighten outer shell **(1)** to strain relief body **(5)**.

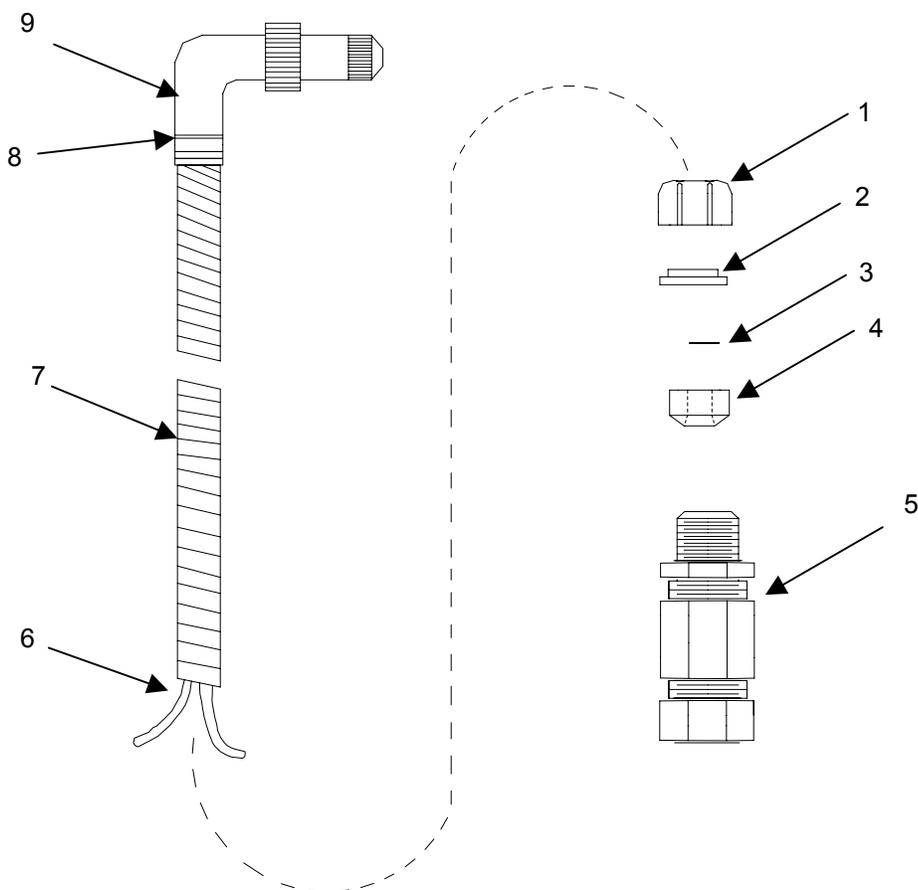

IR Flame Scanner with Strain Relief

7. Screw heat insulator (1) onto sight tube (2) at burner head assembly. Secure heat insulator only hand tight to sight tube. Over tightening will crack insulator.

NOTE

Ensure the burner sight tube is free of obstructions or build-up of soot.
Clean if necessary.

8. Push flame scanner cable thru flexible electrical conduit under water heater. If the strain relief is not already installed on conduit, twist assembled strain relief and flame scanner onto end of electrical conduit until secure.

9. Screw flame scanner (3) onto heat insulator (1) at burner head assembly (2). Secure scanner only hand tight to insulator. Over tightening will damage flame scanner.

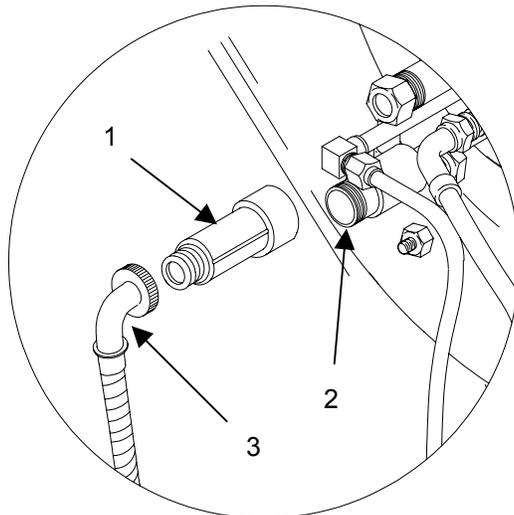

Burner Head Assembly

10. Attach nut (4), bushing (3), and elbow fitting (2) to electrical conduit end (5). Push cable into control box and secure elbow with lock nut (1).
11. Tightly coil any excess flame sensor cable and wire, leaving about 6 inches free and secure with electrical wire ties. Install conduit bushing, removed earlier from scanner cable end, so wires are protected from the sharp edges of the conduit. Place coiled cable under flame control terminal box so it does not interfere with other components.

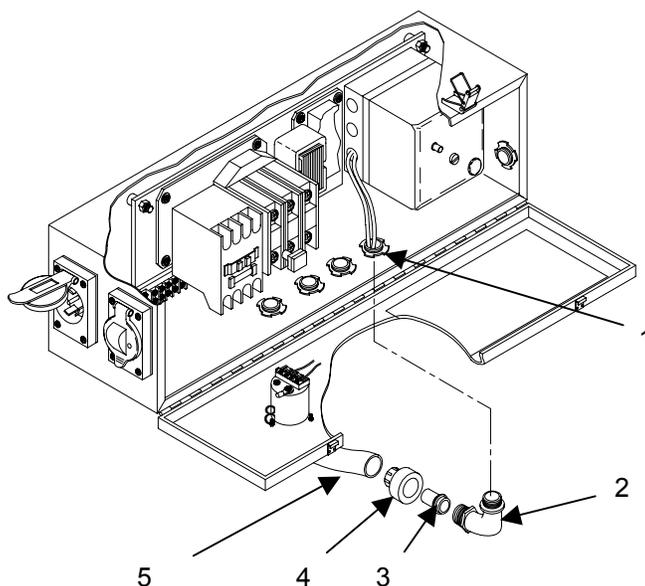

12. Push cable into terminal box. Install wire ends onto S1 and S2 terminals (1). Replace flame control onto terminal box as described under INSTALL UV or IR flame control. Check for normal operation in accordance with WP 0005 00. Close and latch control panel.

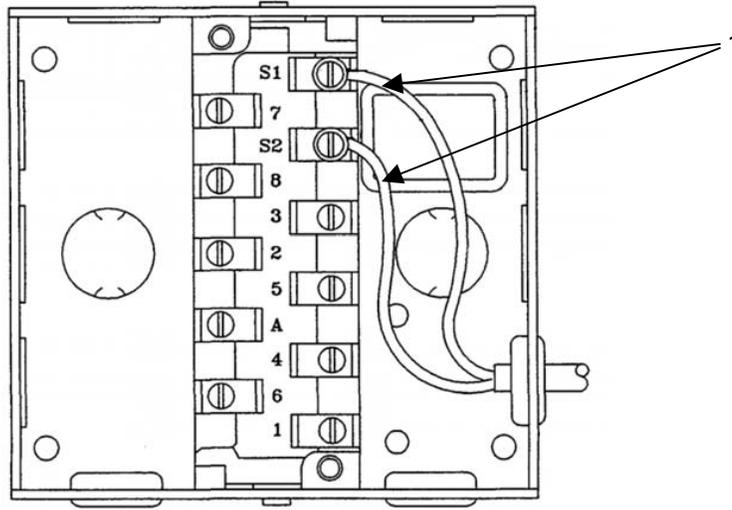

Flame Control Terminal Box

Install an **IR Flame Safeguard Control** as follows:

1. Turn OFF power switch and remove power source and power cable from water heater.
2. Install IR flame safeguard control chassis (3) onto terminal box (2) using two screws (1).

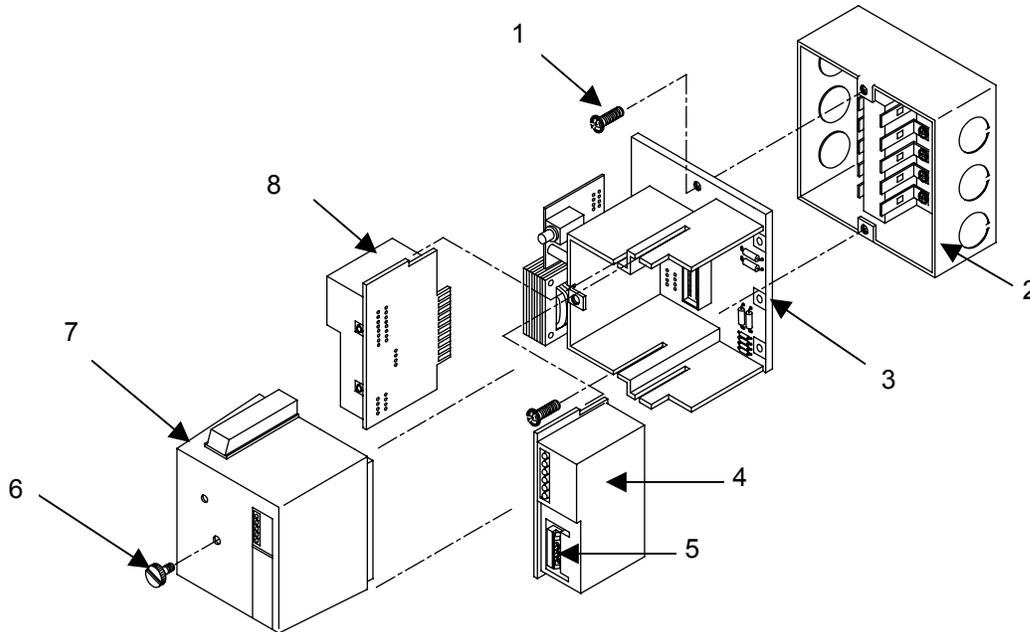

IR Flame Safeguard Control

- The programmer module (4) has a series of switches (5) that must be set to the correct position before the programmer can be installed in the control chassis. Using a pen or small instrument move the switches into the positions shown in the illustration. Note that switches 3, 4, and 5 are in the **OPEN** position while switches 1, 2, and 6 are in the **CLOSED** position. Refer to the label on the module for guidance on the open and closed position.

NOTE

The IR flame control programmer module dipswitch settings will be stored after approximately 8 hours of operation. Changing the switch setting after 8 hours of operation will cause the programmer to malfunction and the control become inoperable. Once stored, the settings cannot be altered.

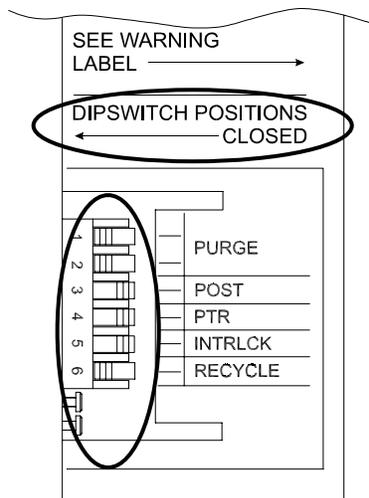

Programmer Label

- After the switches have been set, install the programmer module (4) onto the control chassis (3). The programmer module is inserted into the guide slot farthest from the transformer.

NOTE

Install modules by carefully holding the edges of the printed circuit board and aligning the modules with the guide slots. Do not force modules into slots.

- Install the amplifier module (8) into the control chassis (3). The amplifier module is installed into the slot in the middle of the chassis next to the transformer.
- Place the cover (7) over the control chassis (3) and secure with screw (6). Restore electrical power and check for normal operation in accordance with WP 0005 00. Close and latch control panel cover.

Install an **UV Flame Safeguard Control** as follows:

1. Turn OFF power switch and remove power source and power cable from water heater.
2. Install UV flame safeguard control chassis (5) onto terminal box (4) using two screws (3).

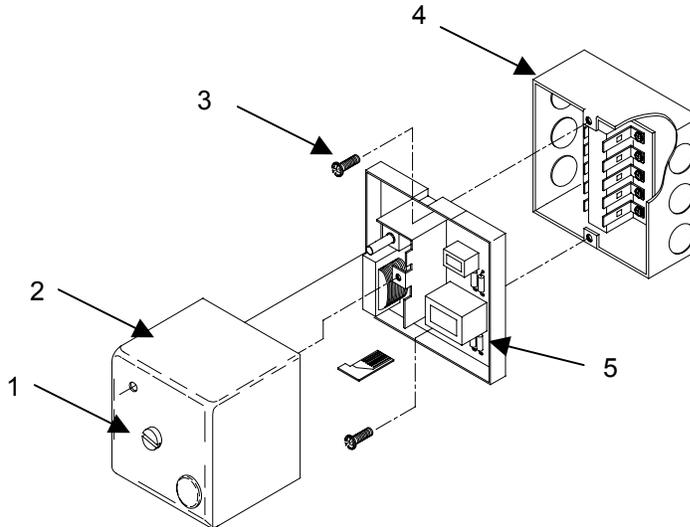

UV Flame Safeguard Control and Terminal Box

3. Place the cover (2) over the control chassis (5) and secure with screw (6). Restore power and check for normal operation in accordance with WP 0005 00. Close and latch control panel cover

END OF WORK PACKAGE

CHAPTER 7

DIRECT SUPPORT TROUBLESHOOTING PROCEDURES
FOR
M-80 AND M-85 LIQUID FUEL WATER HEATER

**DIRECT SUPPORT MAINTENANCE
HEATER, WATER, LIQUID FUEL, M-80 AND M-85
TROUBLESHOOTING INDEX**

TROUBLESHOOTING PROCEDURES

The Malfunction Index lists common malfunctions that may occur during water heater inspection and operation.

Find the malfunction the water heater is having in the index and go to the troubleshooting procedure provided within this work package.

These charts cannot list all malfunctions that may occur, all tests or inspections needed to find the fault, nor all actions required to correct the fault. If your malfunction is not listed in, or is not correctable enough through, this troubleshooting index, notify your supervisor or unit maintenance.

DO NOT START THE TASK UNTIL:

- You understand the task.
- You understand what you are to do.
- You understand what is needed to do the work.
- You have the things you need.

MALFUNCTION SYMPTOM INDEX

Malfunction or Symptom	Refer to Troubleshooting Procedure
System Power Loss	1
Combustion Failure	2
Control Device Failure	3



WARNING

The water heater operates on 208 VAC power. Ensure that the power cable is undamaged, does not lie in water, and is properly connected. Failure to comply may cause serious injury or death to personnel from electrical shock.

Refer to the water heater Power Schematic/Wiring diagram located inside the water heater control box cover. Electrical schematics are provided in this work package.

PROCEDURE 1 COVERS:

System Power Loss

INITIAL SETUP:

Tools

Tool Kit, General Mechanic's, Automotive (Item 3, WP 0038 00)
Multimeter (Item 1, WP 0038 00)

Personnel Required

One

Materials/Parts

Cloth, Cleaning (Item 1, WP 0057 00)

Equipment Condition

Water Heater set-up for operation.

Table 1. Water Heater Troubleshooting Procedures.

MALFUNCTION	TEST OR INSPECTION	CORRECTIVE ACTION
1. System power loss.	Step 1. Check that 208 V 3-ph electrical power is available and correctly connected to the water heater. Check power connections to the water heater.	If not correctly connected, check power source and cables.
	Step 2. Is power switch placed in the ON position?	Place power switch in the ON position.
	Step 3. Has control box sustained damage to interior components?	Replace damaged components as described in WP 0035 00.
	Step 4. Is power available at the interior components?	Using a multimeter set to measure AC power, test for availability of power at the component terminals. Test the UV or IR flame Safeguard control as described in WP 0027 00.
		Replace faulty components as described in WP 0035 00.

PROCEDURE 2 COVERS:

Combustion Failure

INITIAL SETUP:

Tools

Personnel Required

One

Materials/Parts

Cloth, Cleaning (Item 1, WP 0057 00)

Equipment Condition

Water Heater set-up for operation.

Table 1. Water Heater Troubleshooting Procedures - continued.

MALFUNCTION	TEST OR INSPECTION	CORRECTIVE ACTION
2. Combustion failure	Step 1. Are electrical components of water heater under power?	Perform Procedure 1: System Power Loss
	Step 2. Is a fuel source available and properly connected to the water heater?	Connect a fuel source supplying one of the approved fuels to the water heater as described in WP 0005 00.
	Step 3. Are electrodes sparking during startup?	Using a multimeter, test the ignition system components and replace faulty parts as necessary.
	Step 4. Is fuel available at the nozzle during startup?	Disconnect fuel supply and return hoses and check operation of fuel pump and fuel filter. Check for proper fuel pressure setting as described in WP 0005 00.
		Replace any faulty component as necessary.

PROCEDURE 3 COVERS:

Control Device Failure

INITIAL SETUP:

Tools

Tool Kit General Mechanic's, Automotive (Item 3, WP 0038 00)
Multimeter (Item 1, WP 0038 00)

Personnel Required

One

Materials/Parts

Cloth, Cleaning (Item 1, WP 0057 00)

Equipment Condition

Water Heater set-up for operator.

Table 1. Water Heater Troubleshooting Procedures continued.

MALFUNCTION	TEST OR INSPECTION	CORRECTIVE ACTION
3. Control Device Failure.	Step 1. Is temperature control malfunctioning?	Test and if necessary, replace temperature control device as described in WP 0029 00.
	Step 2. Is high temperature control device malfunctioning?	Test and if necessary, replace high temperature control device as described in WP 0029 00.
	Step 3. Is low water sensor malfunctioning?	Test and if necessary, replace low water sensor as described in WP 0029 00
	Step 4. Is flame safeguard control malfunctioning?	Test and if necessary, replace the UV flame Safeguard Control with an IR Control as described in WP 0027 00. If the malfunctioning device is an infrared Control, check and replace the fuse on control chassis.
		Review the water heater start-up procedures in WP 0005 00 and restart the water heater.

END OF WORK PACKAGE

CHAPTER 8

DIRECT SUPPORT MAINTENANCE INSTRUCTIONS FOR M-80 AND M-85 LIQUID FUEL WATER HEATER

**DIRECT SUPPORT MAINTENANCE
HEATER, WATER, LIQUID FUEL M-80 AND M-85
NSN 4520-01-162-0385 (M-80) 4520-01-237-3719 (M-85)
ELECTRICAL COMPONENTS
INSPECT, TEST, REMOVE, INSTALL**

INITIAL SETUP:**Tools**

Tool Kit, General Mechanic's, Automotive (Item 3, WP 0038 00)
Multimeter (Item 1, WP 0038 00)

Personnel Required

One

Materials/Parts

Cloth, Cleaning (Item 1, WP 0057 00)
Tag (Item 13, WP 0057 00)
Tape, Insulation, Electrical (Item 14, WP 0057 00)

Equipment Condition

Water heater shut down, cooled down, power disconnected.

INSPECT

Inspect the operating control, high limit control, electrode holder, UV or IR flame control, conduits, electrical fittings and wiring for physical damage, rust, corrosion, frayed or exposed electrical wires. Replace damaged and faulty components as described in the following procedures.

**WARNING**

Lethal voltage is present when the water heater is connected to a power source. Disconnect the water heater from its power source before performing the following procedures. Be careful not to touch electrical connections. Serious injuries or death from electrocution may result.

NOTE

Two different flame control systems may be found on the M-80 and M-85 Water Heater: The original ultraviolet (UV) scanner, or the newer infrared (IR) type scanner. Though the two scanners appear slightly different, replacement procedures for both types are essentially the same.

TEST

To perform a continuity test on the operating and high limit control, proceed as follows:

1. Remove inspection plate **(1)** and gasket **(2)** from Tee Box **(3)**.
2. Remove the wire nuts **(4)** from both orange **(5)** and red **(6)** wires.
3. Set knob **(7)** on operating control **(8)** to zero.
4. Turn Knob **(7)** operating control **(8)** clockwise until a click is heard.
5. With a multimeter set to read Ohms, perform a continuity check between the red wire **(6)** to the operating control **(8)**, and the orange wire **(5)** to the high limit switch. If continuity exists the controls are serviceable. If no continuity exists, continue with step 6.

6. Disconnect red **(6)** and orange **(5)** wires.
7. Perform continuity check on red wire **(6)** from operating control **(8)** thermostat. Perform continuity check on orange wire to high limit switch **(5)**.
8. If correct readings do not register, leave one lead on the red wire **(6)**, and place other lead on the common terminal of the high limit switch.
9. Rotate knob **(7)** on operating control **(8)** clockwise until click is heard. Multimeter reading should be zero ohms. Rotating the knob **(7)** counterclockwise should read infinity. If these readings do not register, replace the operating control. If readings do register, replace the high limit control.

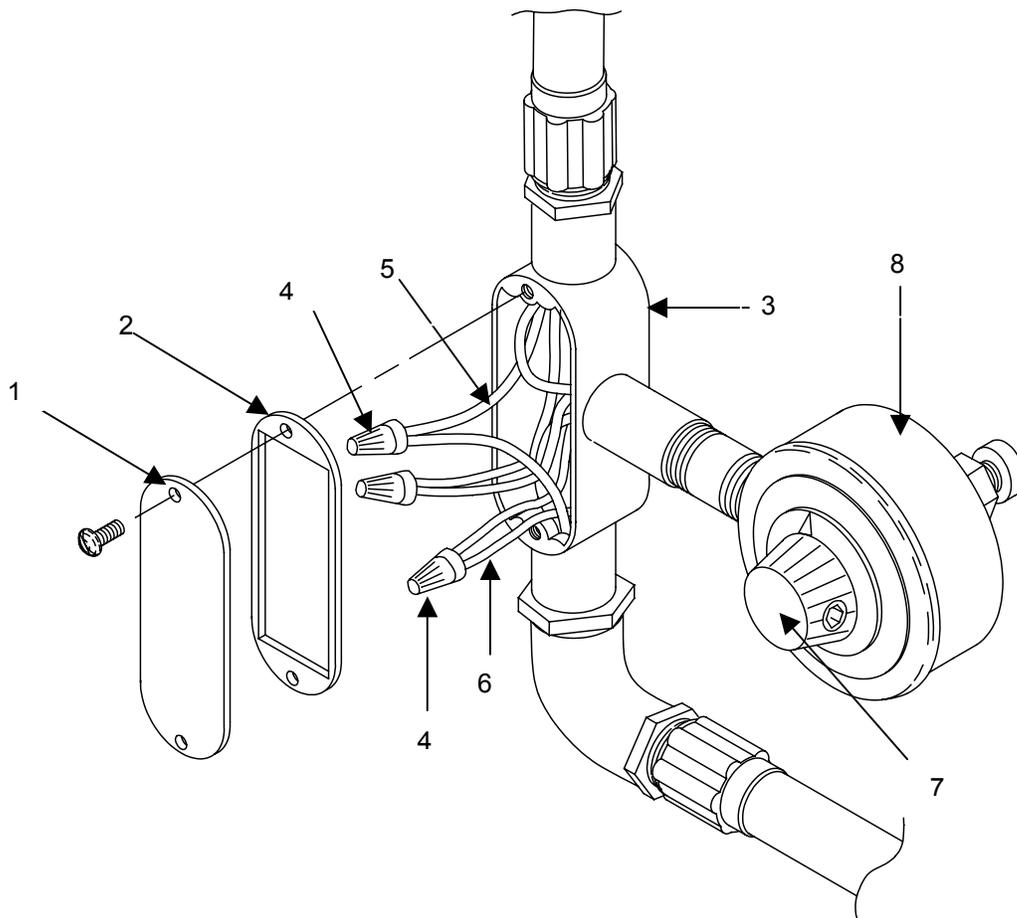

REMOVE

To remove the electrical components, proceed as follows:

1. To remove the operating control, remove the control knob (1) by loosening the setscrew (2) and pulling the knob off the stem.
2. Remove the nut (3) on the faceplate (4).
3. Remove the faceplate (4) from the operating control housing (5).
4. Remove wires (6) from terminal plate.
5. Remove inspection plate (7) and gasket (8) from Tee box (9).
6. Pull operating control wires (10) out of operating control housing (5).
7. Remove conduit lock nut (11) inside the operating control housing (5).
8. Unscrew two nuts (12) on conduit.
9. Unscrew nipple (13) from operating control housing (5) and Tee Box (9).
10. Remove the operating control housing (5) from the water heater by unscrewing the nut (14) located behind the housing.

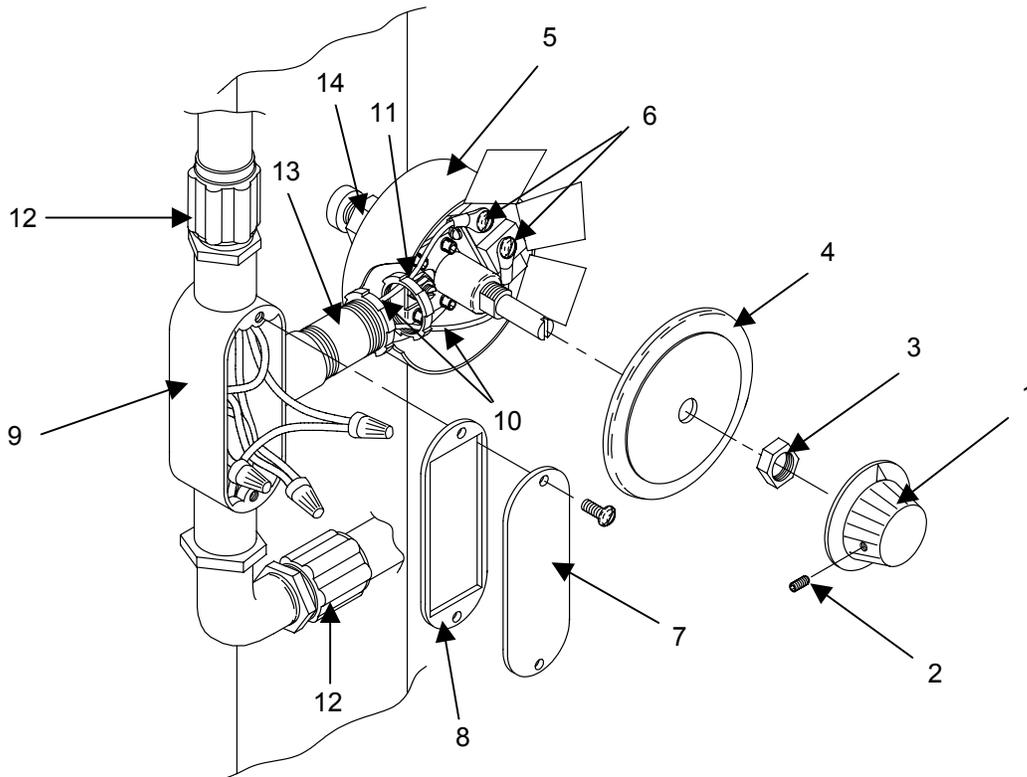

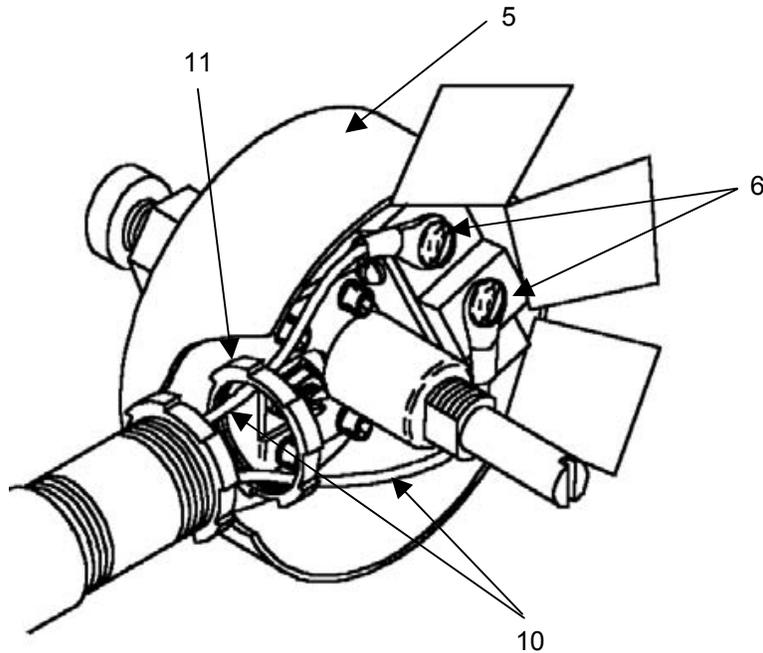

To remove the high limit control, proceed as follows:

1. Loosen cover screw **(1)** and remove cover **(2)** from high limit control housing **(3)**.
2. Remove wires **(4)** from high limit switch terminal block.
3. Loosen conduit lock nut **(5)** inside high limit control housing **(3)**.
4. Remove inspection plate **(6)** and gasket **(7)** from Tee Box **(8)**.
5. Pull wires **(4)** out of high limit control housing **(3)**.
6. Loosen two nuts **(9)** on conduit and pull conduit out of high limit control housing **(3)**.
7. Remove high limit control housing **(3)** by unscrewing the nut **(10)** behind the housing.

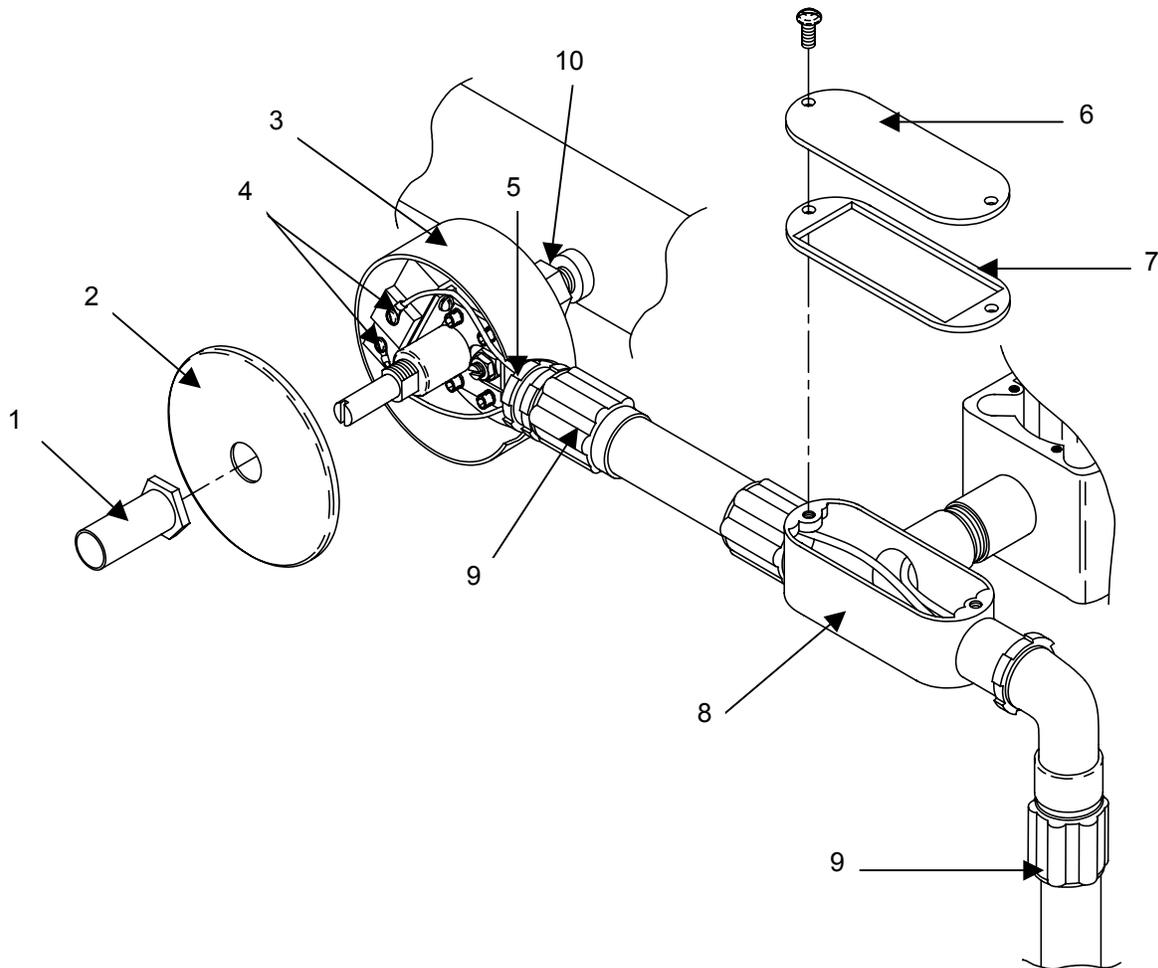

To remove the electrode (low water sensor), proceed as follows:

1. To remove the electrode (1) from holder (2) loosen four screws (3) and remove cover (4) from the electrode holder (2).
2. Disconnect blue wire from the terminal (5) inside the electrode holder (2).
3. Remove inspection plate (6) and gasket (7) from Tee box (8).
4. Pull blue wire out of electrode holder (2).
5. Unscrew and remove electrode (1) from the holder (2).
6. Remove nut (9) and cover (10) from high limit switch. Remove wires (11) from switch terminals.
7. Disconnect two nuts (12) on conduit and pull wires out of conduit.
8. Unscrew electrode holder (2) from tank (with Tee box (8) attached).
9. Unscrew electrode holder (2) from Tee box (8).

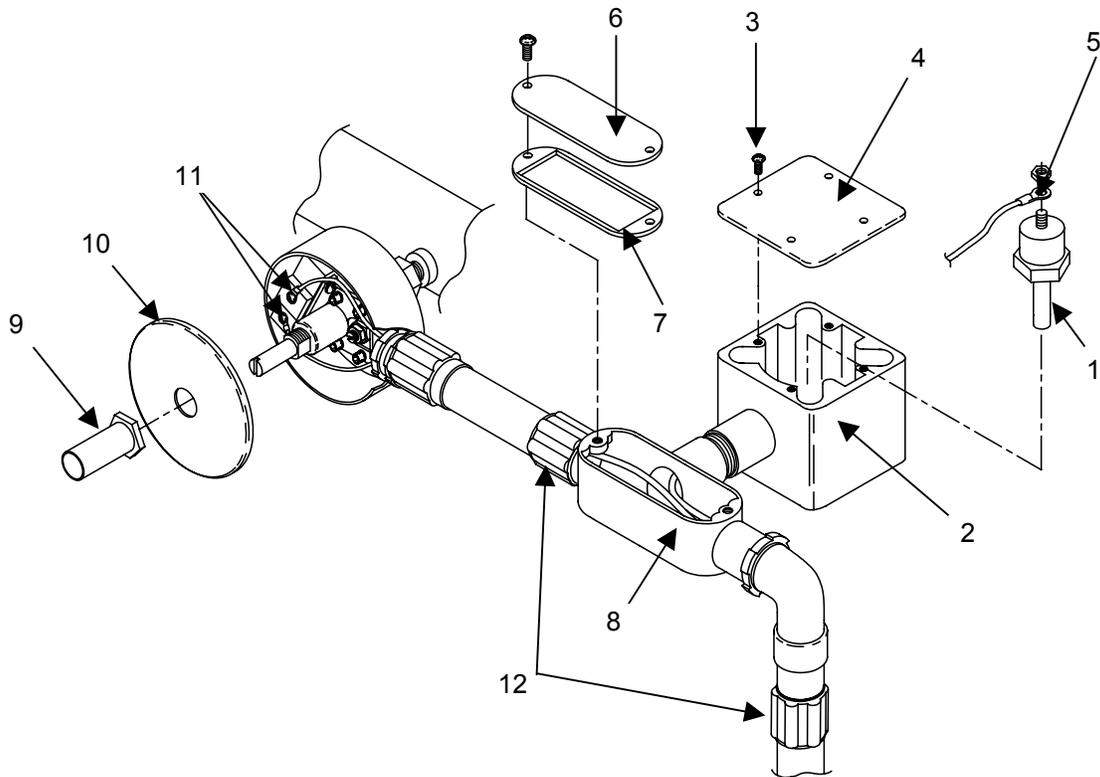

To remove flexible and rigid conduit components from the water heater proceed as follows:

1. Remove conduit components by disconnecting wires at the upper **(1)** or lower **(2)** tee box, or the control box **(3)**, whichever is nearer the component to be replaced.
2. To remove flexible conduit **(4)** from control box, tag and disconnect wires **(5)** inside control box.
3. Remove rigid conduit lock nut **(6)** and push elbow connector **(7)** out of box.
4. Disassemble conduit components by unscrewing connector **(8)**, removing elbow **(7)**, ground cone **(9)**, nipple **(10)**, and lock nuts **(6)**, as appropriate.
5. To remove connectors **(8)** from conduit **(4)**, unscrew nut **(11)** from connector **(8)** and disengage conduit.
6. Remove ground cone **(9)** from conduit **(4)**. Then slip nylon ring **(12)** and nut **(11)** from conduit.

INSTALL

To install new flexible and rigid conduit components onto the water heater, disassemble the conduit as described under REMOVE, above, and reassemble with new components as necessary.

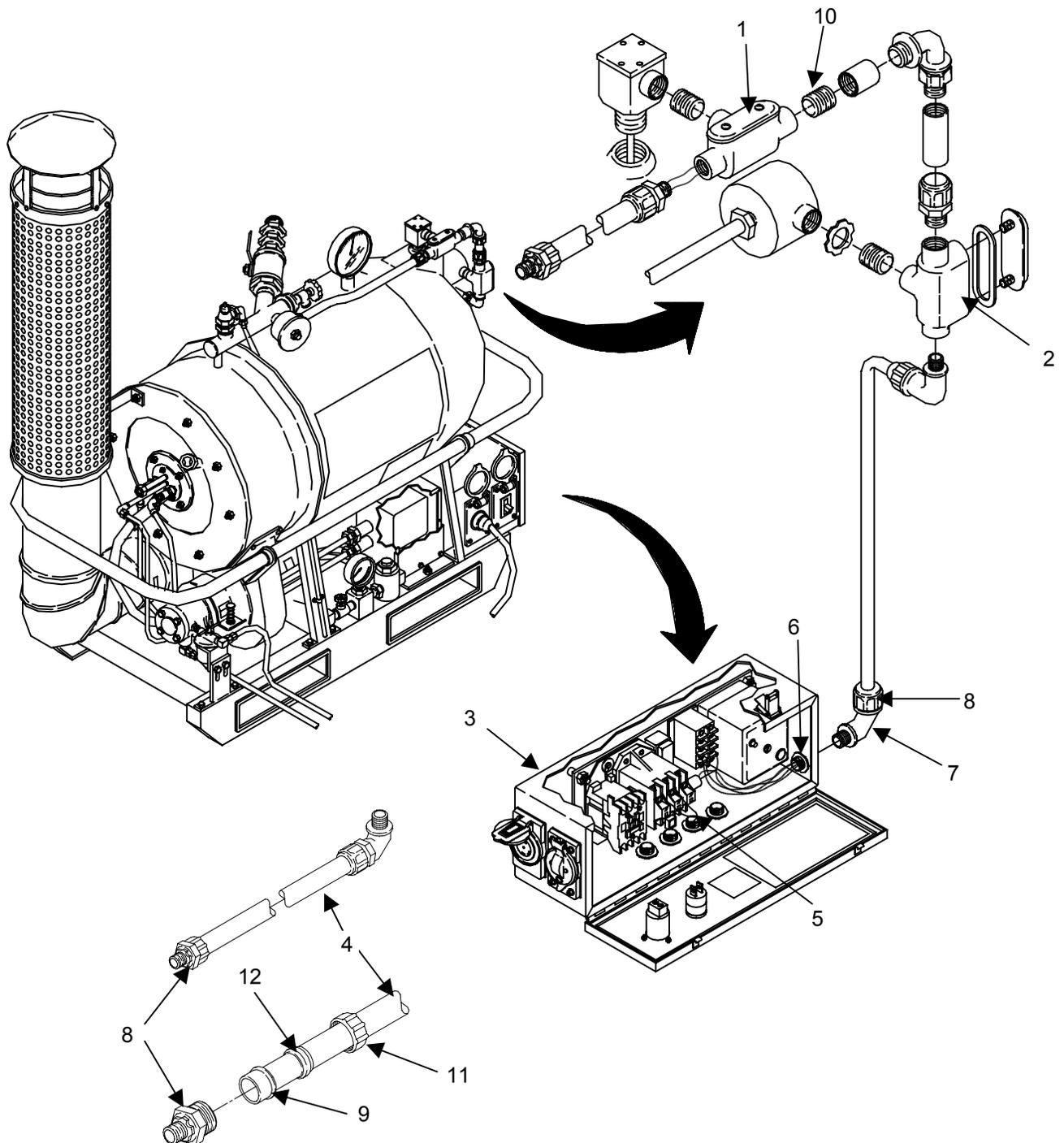

To install the operating control, proceed as follows:

1. Position the operating control housing (1) onto the water heater and secure it by tightening the nut (2) located behind the housing.
2. Install nipple (3) into operating control housing (1) and Tee box (4).
3. Tighten two nuts (5) on conduit.
4. Install and tighten conduit lock nut (6) inside the operating control housing (1).
5. Pass operating control wires (7) through conduit into operating control housing (1).
6. Install inspection plate (8) and gasket (9) onto Tee box (4).
7. Install wires (10) onto terminal plate.
8. Position the faceplate (11) onto the operating control housing (1).
9. Install nut (12) on the faceplate (11).
10. Position the control knob (13) onto the shaft and secure with setscrew (14).

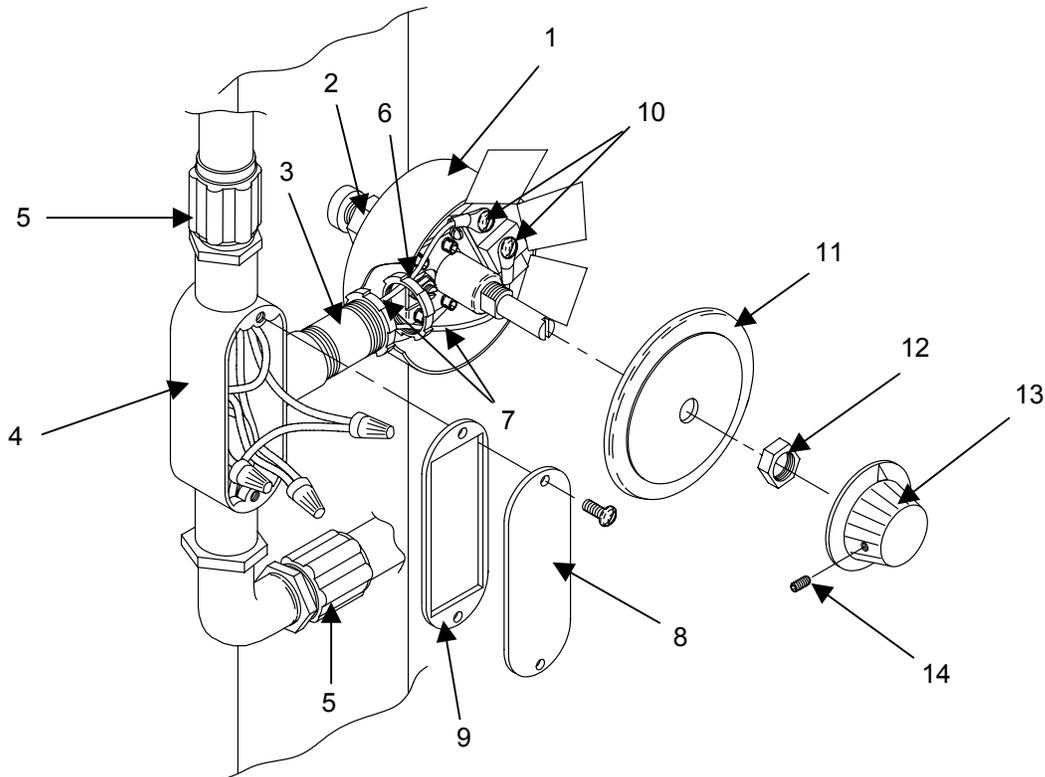

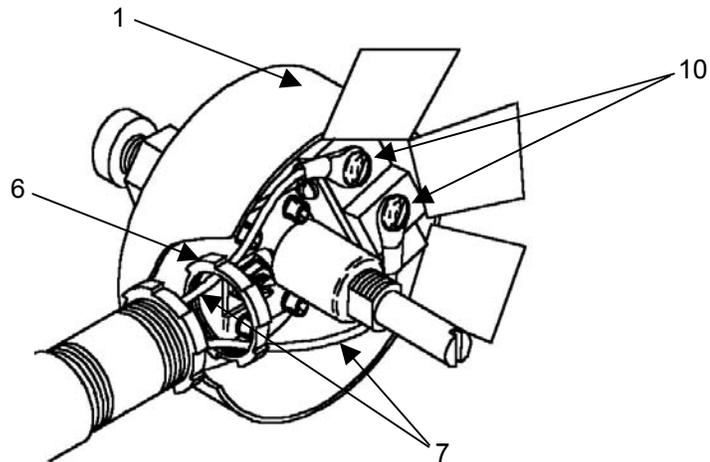

To install the high limit control, proceed as follows:

1. Place high limit control housing **(1)** into position and secure by tightening the nut **(2)** behind the housing.
2. Insert conduit end into high limit control housing **(1)** and tighten two nuts **(3)** on conduit.
3. Push wires **(4)** through conduit and into high limit control housing **(1)**.
4. Install inspection plate **(5)** and gasket **(6)** onto Tee box **(7)**.
5. Tighten conduit lock nut **(8)** inside high limit control housing **(1)**.
6. Install wires **(4)** from high limit switch terminal block.
7. Place cover **(9)** onto high limit control housing **(1)** and secure with screw **(10)**.

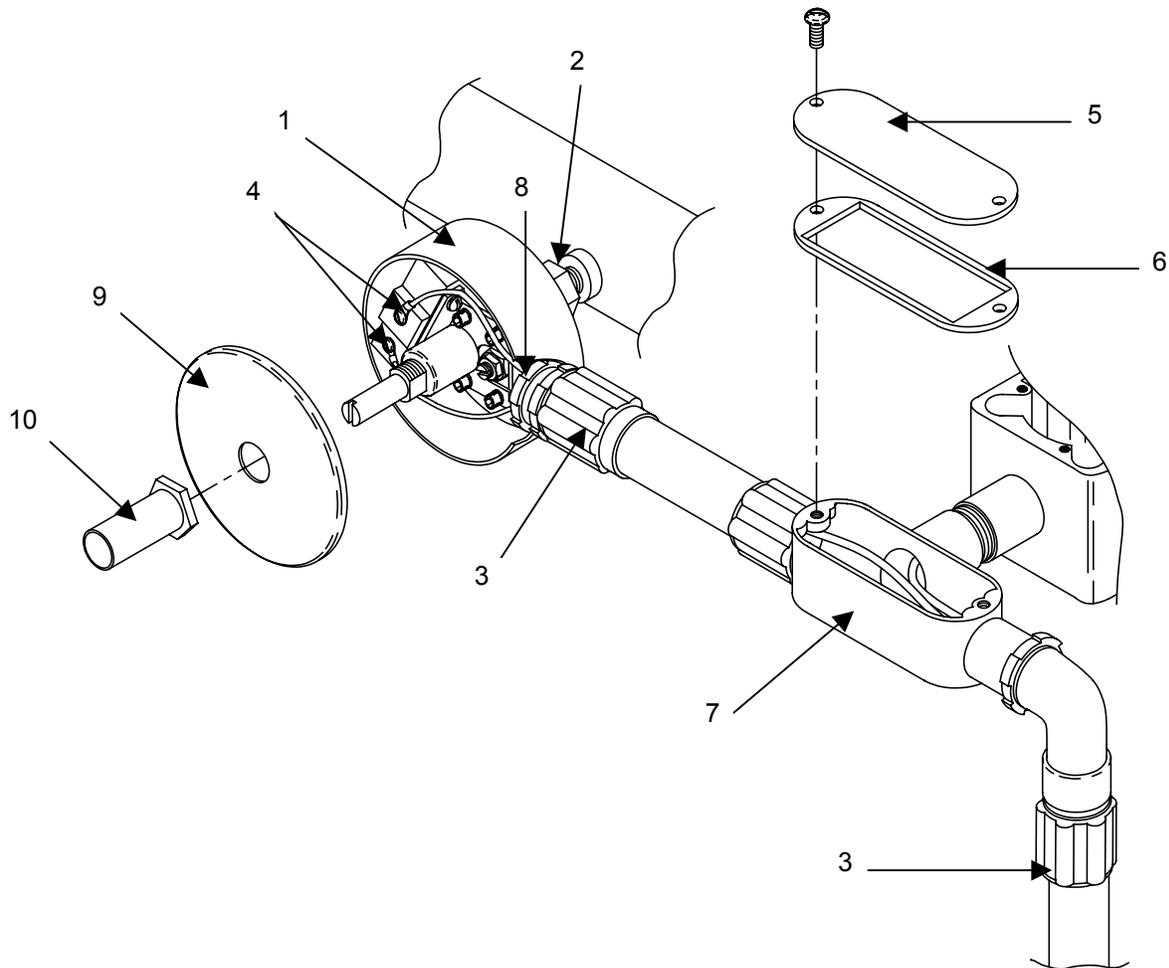

To install the electrode and holder, proceed as follows:

1. Screw electrode holder **(1)** onto nipple on Tee box **(2)**.
2. Screw electrode holder **(1)** into tank (with Tee box **(2)** attached).
3. Push wires through conduit and tighten two nuts **(3)** on conduit.
4. Install wires **(4)** onto high limit switch terminals. Place cover **(5)** into position and secure with nut **(6)**.
5. Place electrode **(7)** into electrode holder **(1)** and tighten.
6. Push blue wire through conduit into electrode holder **(1)**.
7. Install gasket **(8)** and inspection plate **(9)** onto Tee box **(2)**.
8. Connect blue wire to the terminal **(10)** inside the electrode holder **(1)**.

9. Place cover (11) and gasket (12) on electrode holder (1) and install four screws (13) to secure it.

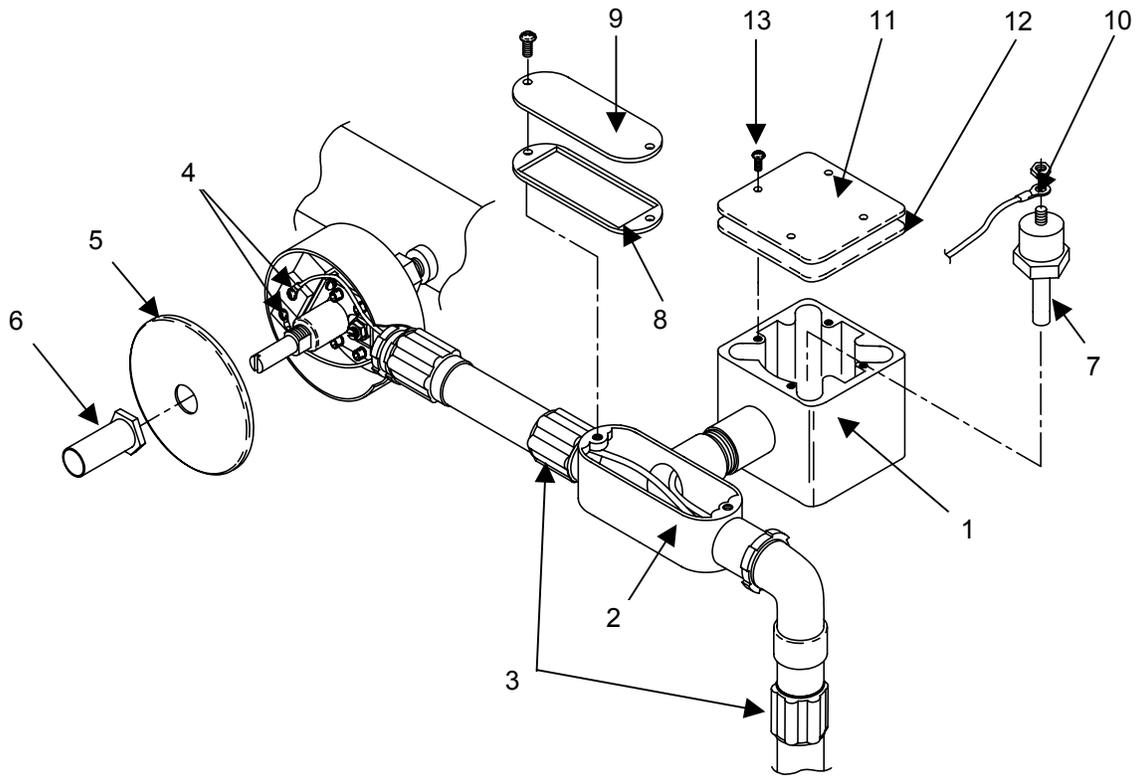

END OF WORK PACKAGE

**DIRECT SUPPORT MAINTENANCE
HEATER, WATER, LIQUID FUEL M-80 AND M-85
NSN 4520-01-162-0385 (M-80) 4520-01-237-3719 (M-85)
BLOWER ASSEMBLY
INSPECT, REMOVE, REPAIR, INSTALL**

INITIAL SETUP:**Tools**

Tool Kit, General Mechanic's, Automotive (Item 3, WP 0038 00)

Personnel Required

One

Materials/Parts

Cloth, Cleaning (Item 1, WP 0057 00)

Equipment Condition

Water heater shut off, cooled down.
Power switch off, power cable disconnected.

INSPECT

1. Inspect the blower assembly for leaks, corrosion, damage, or loose components.
2. Check for indication of burns around the blower motor.
3. Check for free movement of the blower. Replace any faulty components.

REMOVE**WARNING**

When disassembling the blower assembly components, avoid fuel spills. Serious injuries from igniting fuel or explosion could result.

Remove the blower assembly as follows:

1. Disconnect fuel supply hose (1) from elbow (2), elevate hose to allow fuel to drain back into container (3), and then rest hose on container.
2. Disconnect fuel return hose (4) from elbow (5), elevate hose to allow fuel to drain back into container (3), and then rest hose on container.

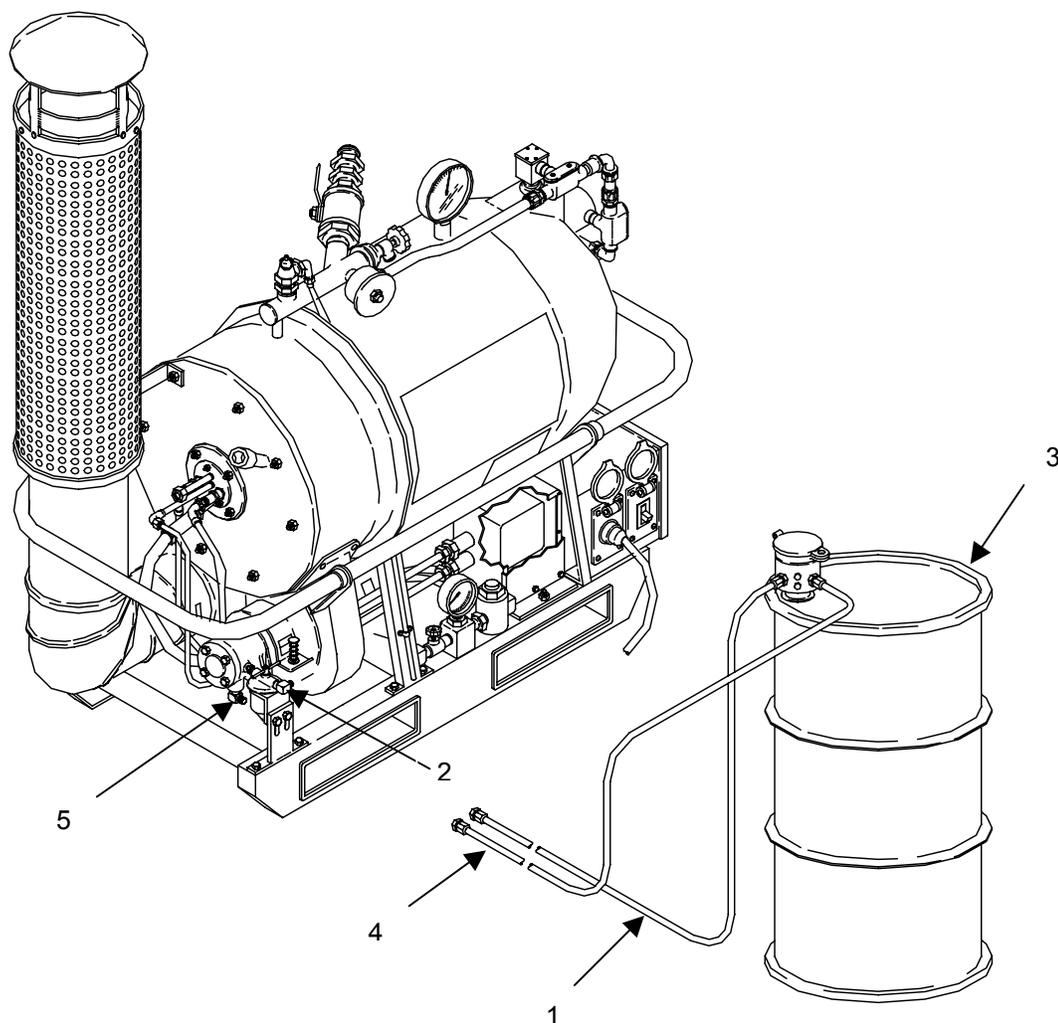

3. Remove two nuts **(6)**, two lock washers **(7)**, two flat washers **(8)**, and two screws **(9)** from fuel filter pump bracket **(10)**.
4. Disconnect fuel line **(11)** from fuel pump to solenoid valve **(12)**.
5. Disconnect elbow **(13)** from fuel pump.
6. On backside of blower assembly, unscrew one screw **(14)** and remove cover plate with gasket **(15)**.
7. Tag and disconnect wires **(16)** and remove nut **(17)** Push connector **(18)** down, disconnecting it from junction box **(19)**.

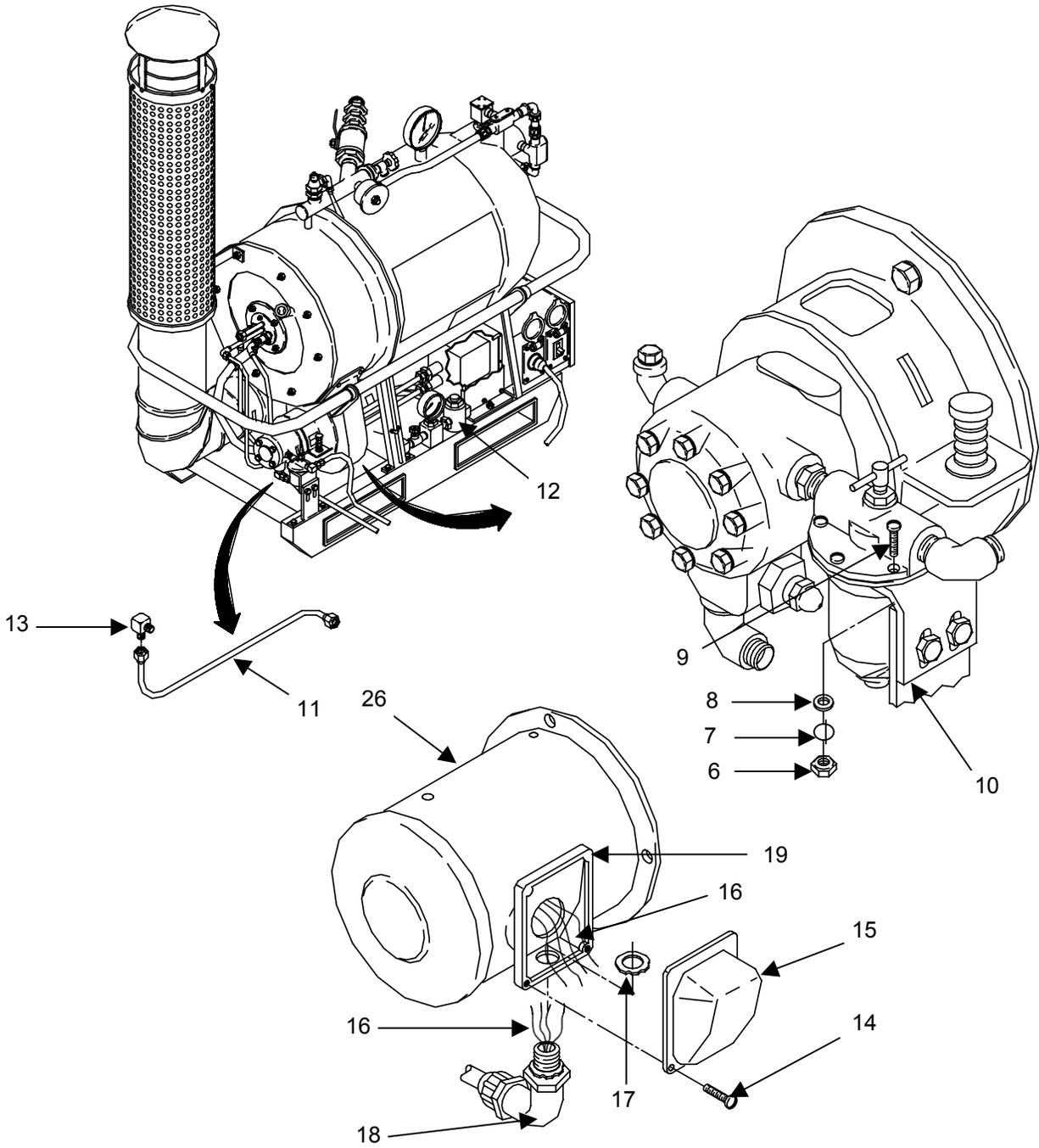

8. Remove two cap screws (20) and lock washers (21) securing handle assembly (22) to blower housing (23).
9. Remove six hex head screws (24) and lock washers (25) holding blower housing (23) to water vessel (26).
10. Remove blower housing (23) with motor (27) attached from water vessel (26).
11. Separate gasket (28) from blower housing (23).

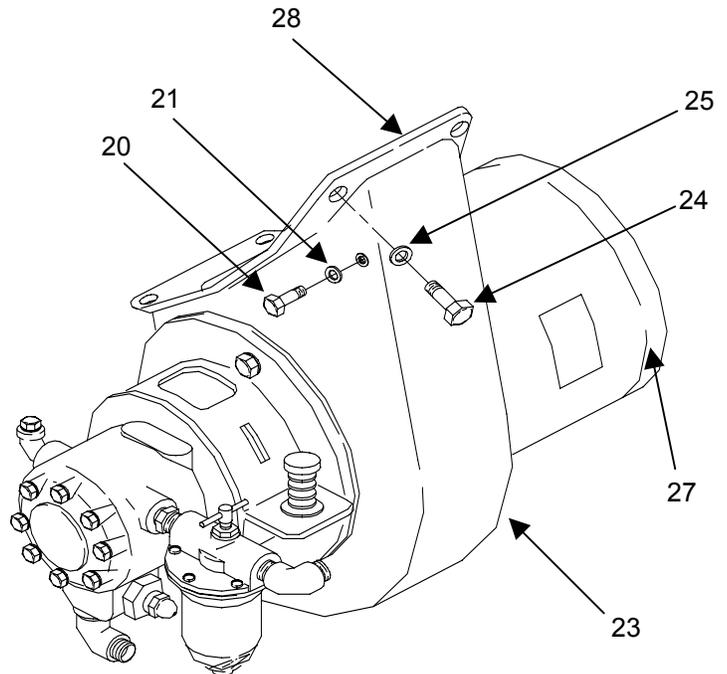
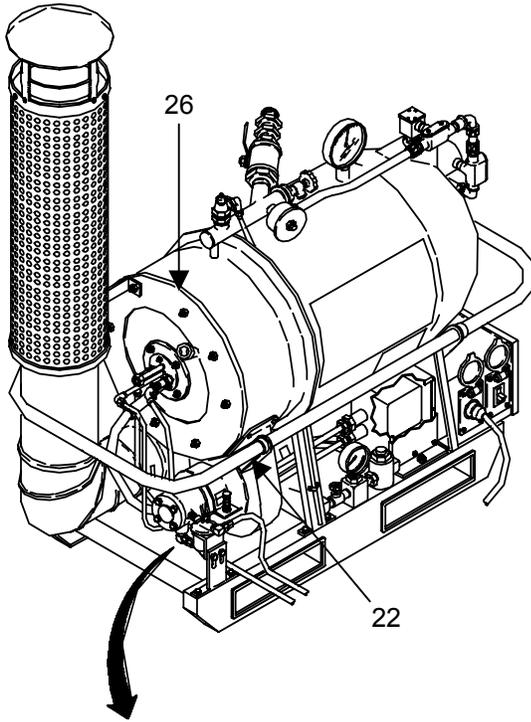

REPAIR

Repair the blower assembly by removing rust or corrosion and tightening components to ensure free movement of blower. Replace any components that cannot be repaired.

INSTALL

1. Place gasket (1) on blower assembly (2). Set blower assembly on water vessel (3). Secure handle assembly (4) to blower housing using two cap screws (5) and lock washers (6).
2. On the backside of the blower assembly, insert conduit connector (7) into junction box (8) and secure with nut (9).
3. Connect tagged wires (10), install cover plate (11) using one screw (12).
4. Replace gasket (1) on blower housing (2). Mount blower housing (2) in position and secure with six hex head screws (13) and lock washers (14).
5. Connect elbow (15) to fuel pump.
6. Secure handle assembly (4) to blower housing (2) using two cap screws (5) and lock washers (6).
7. Connect fuel line (16) from solenoid valve (17) to elbow (15).
8. Install two screws (18), two flat washers (19), two lock washers (20) and two nuts (21).
9. Connect fuel return hose (22) to elbow (15) and connect fuel line (16) to elbow (15).

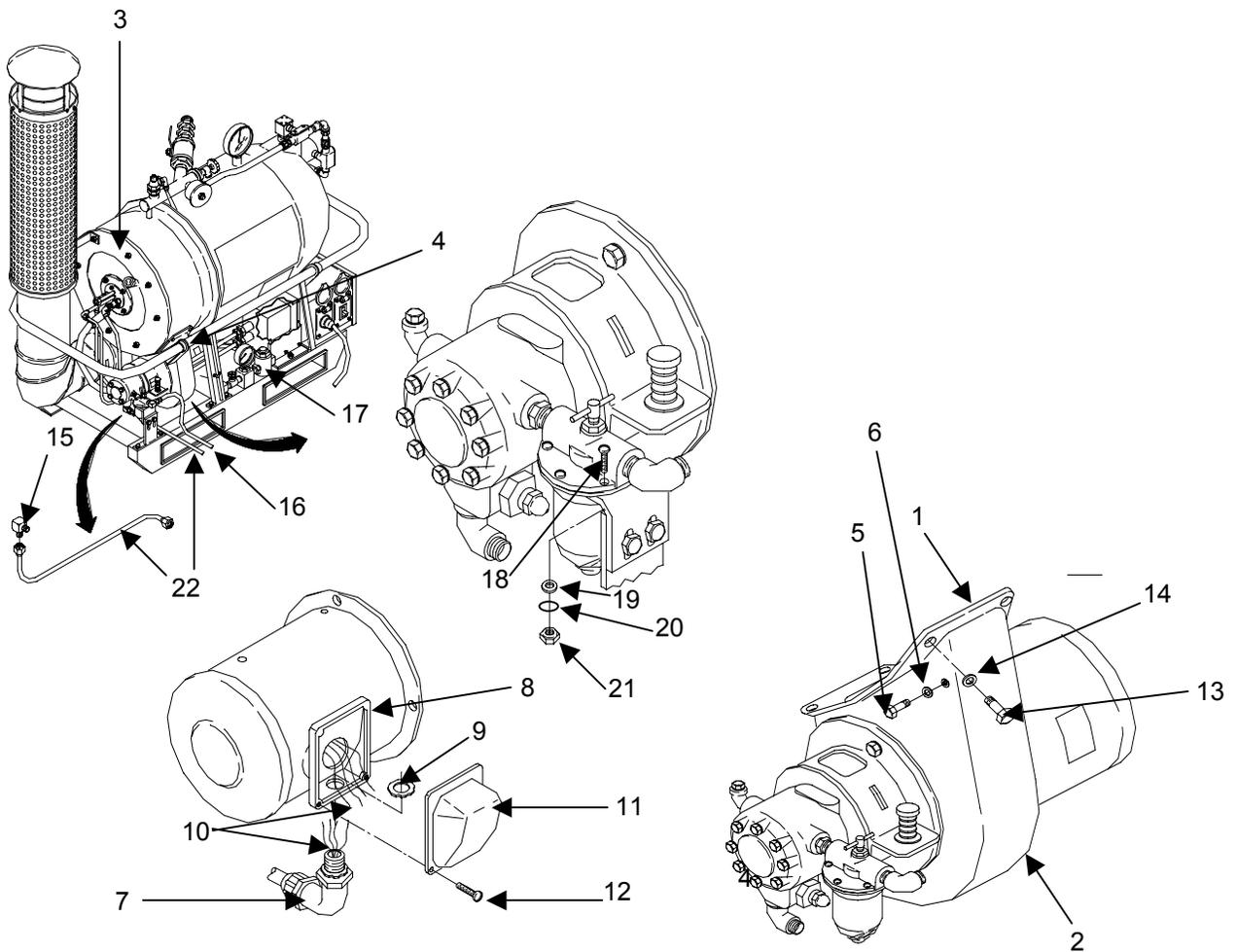

END OF WORK PACKAGE

**DIRECT SUPPORT MAINTENANCE
HEATER, WATER, LIQUID FUEL M-80 AND M-85
NSN 4520-01-162-0385 (M-80) 4520-01-237-3719 (M-85)
BLOWER AND FUEL PUMP MOTOR
REMOVE, INSPECT, TEST, REPAIR, INSTALL**

INITIAL SETUP:**Tools**

Tool Kit, General Mechanic's, Automotive (Item 3, WP 0038 00)

Personnel Required

One

Materials/Parts

Cloth, Cleaning (Item 1, WP 0057 00)
Solvent (Item 12, WP 0057 00)

Equipment Condition

Water heater shut off, cooled down.
Power switch off, power cable disconnected.

REMOVE**WARNING**

When disassembling the blower and fuel pump motor components, avoid fuel spills. Serious injuries from igniting fuel or explosion could result.

Remove the blower and fuel pump motor as follows:

1. Remove blower assembly from water heater as described in work package 0028 00 under REMOVE.
2. Remove four cap screws **(1)**, and four lock washers **(2)**.
3. Loosen setscrews **(3)** on coupling half **(4)** from shaft **(5)**.
4. Slide motor **(6)** out of blower housing **(7)**. The rubber spider insert **(8)** may come out with either coupling half **(4)** attached to shaft **(5)**. If it comes loose, attach it to the coupling half **(4)** attached to the motor.
5. Carefully pry blower wheel **(9)** from shaft **(5)**. Lift key **(10)** from blower shaft.
6. Remove four machine screws **(11)** securing mounting plate **(12)** to motor **(6)** and remove plate.

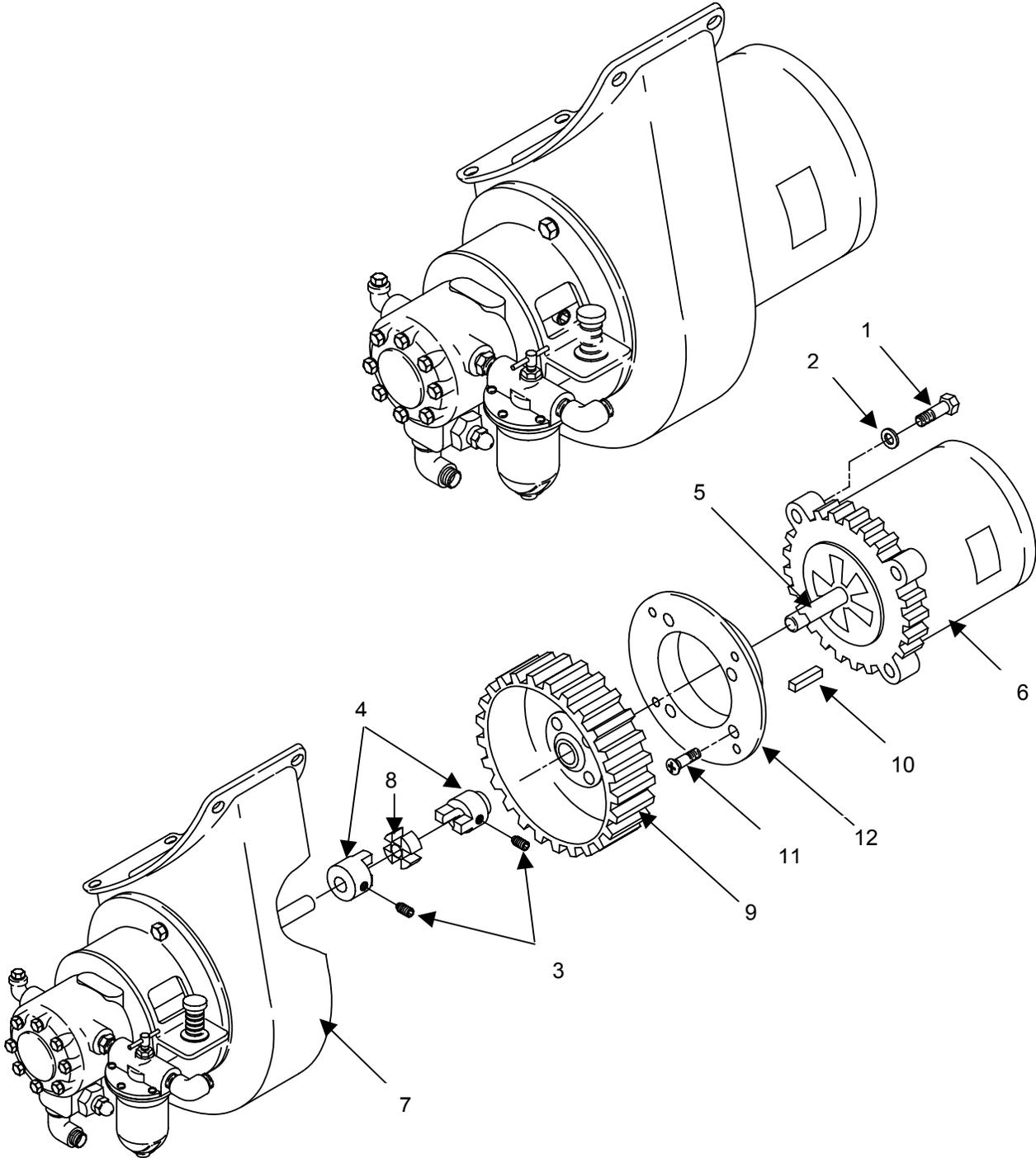

INSPECT

Inspect the blower and fuel pump motor for damage, burrs nicks, bent fan blades, loose components or burned and broken wires.

TEST

To test the blower motor for continuity, proceed as follows:

1. Using a multimeter **(1)** set to read resistance (ohms), test for continuity between each lead **(2)** coming from the motor. Do not check the ground wire. There should be some resistance, but there should not be a short (0 ohms) or an open winding (∞ ohms). Replace a motor with a shorted or open winding.
2. Using a multimeter **(1)** set to read resistance (ohms), test for continuity between each lead **(2)** coming from the motor and the ground wire or the motor case **(3)**. There should be infinite resistance (∞ ohms). Replace a motor with a short to ground.

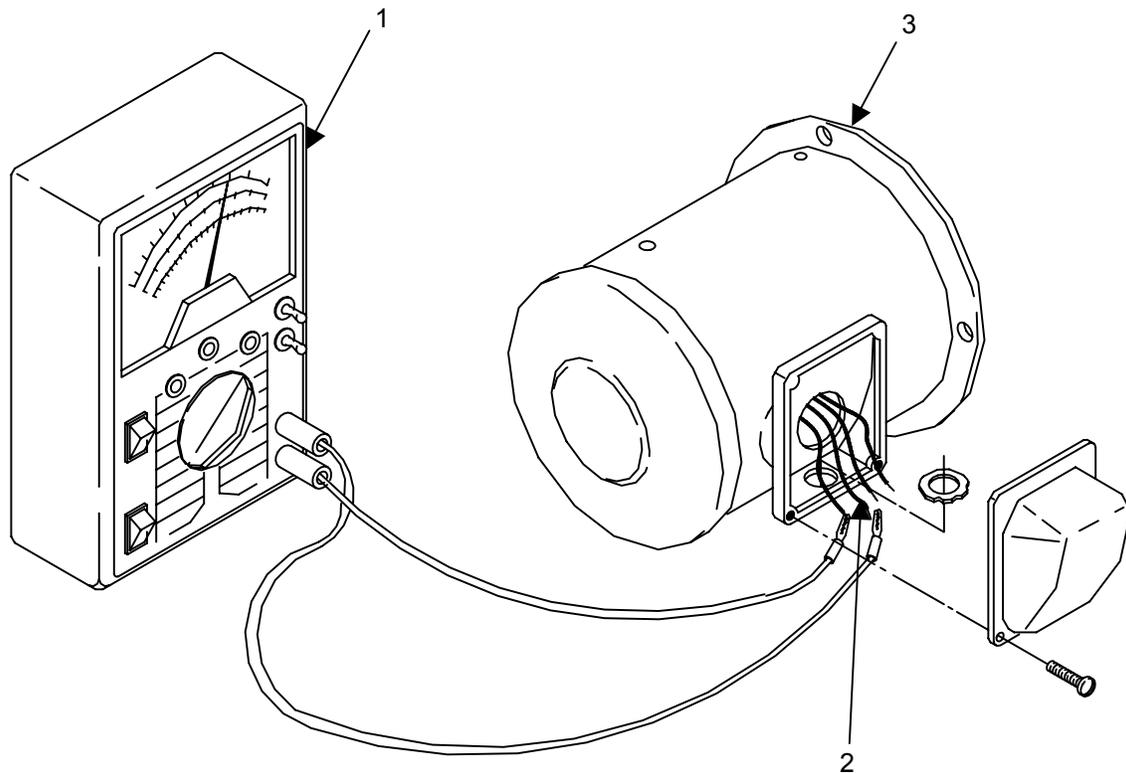

REPAIR

Repair the blower and fuel pump motor by replacing damaged or worn out parts detected during inspection as follows:

1. Mark **(1)** motor housing **(2)** and end plates **(3)** for ease in reassembly.
2. Remove four bolts **(4)** holding end plates **(3)** to housing **(2)**.
3. Remove bearings **(5)** from motor **(6)**. Clean all parts except bearings with a clean dry cloth. Clean bearings with a clean, lint free cloth moistened in light engine oil.
4. Inspect for broken, cracked or burned motor **(6)** and bent shaft **(7)**, bent fins **(8)**, end plate **(9)**, and damaged wiring. If any of these items are damaged, replace motor.
5. If bearings **(5)** are rough or excessively worn, replace bearings.
6. Install bearings **(5)** onto motor **(6)**. Install end plates **(9)** into motor housing **(2)** in alignment with mark **(1)** on motor housing.
7. Secure using four bolts **(4)**.

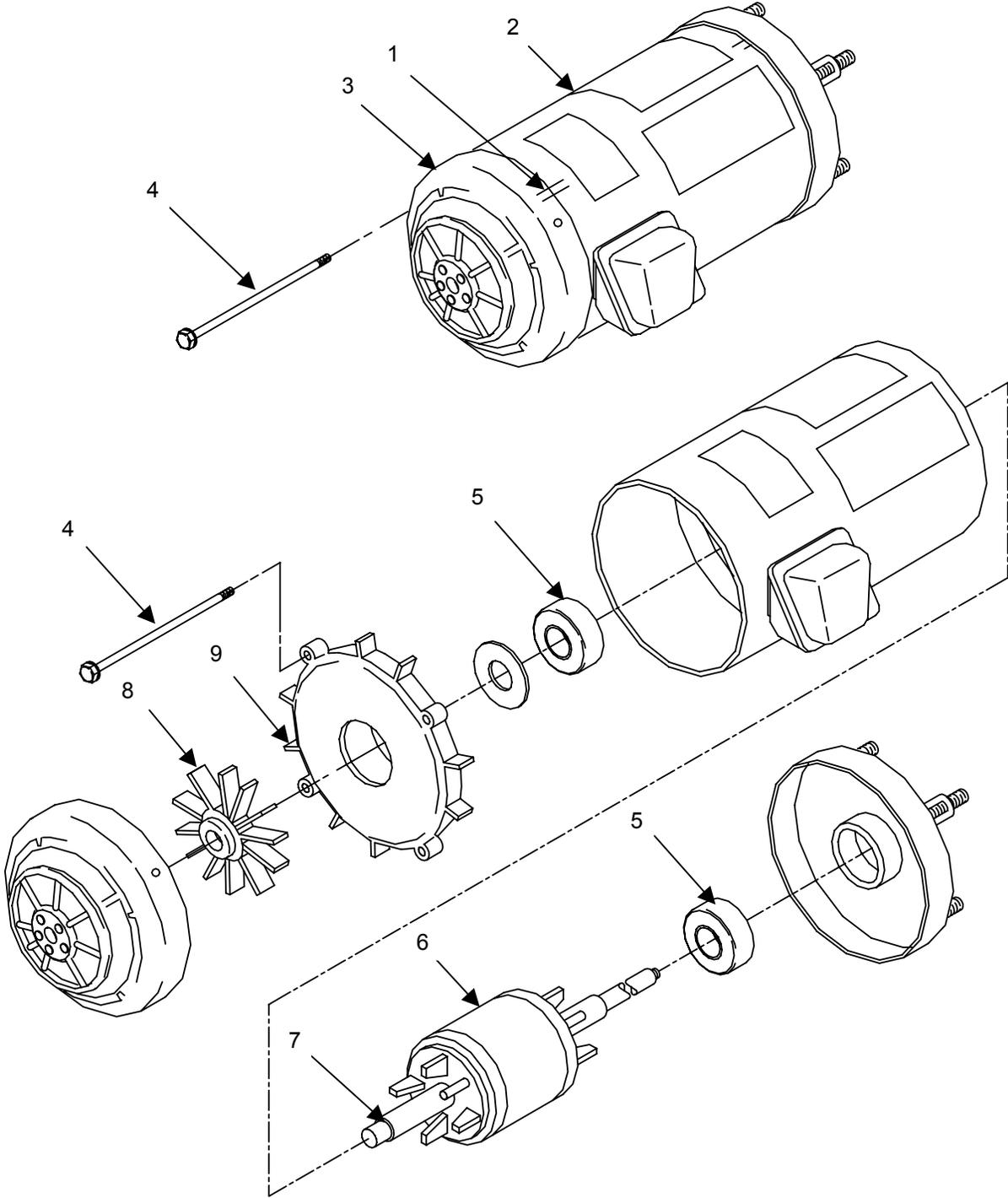

INSTALL

1. To install blower and fuel pump motor, set mounting plate (1) in place on motor (2) and secure with four machine screws (3).
2. Insert key (4) on shaft (5) and press blower wheel (6) on shaft.
3. Place coupling halves (7) and rubber insert (8) into position and tighten setscrews (9).
4. Set motor (2) in place on blower assembly (10) and secure with four cap screws (11) and four lockwashers (12).
5. Install blower assembly to water heater as described in work package 0028 00 under INSTALL.

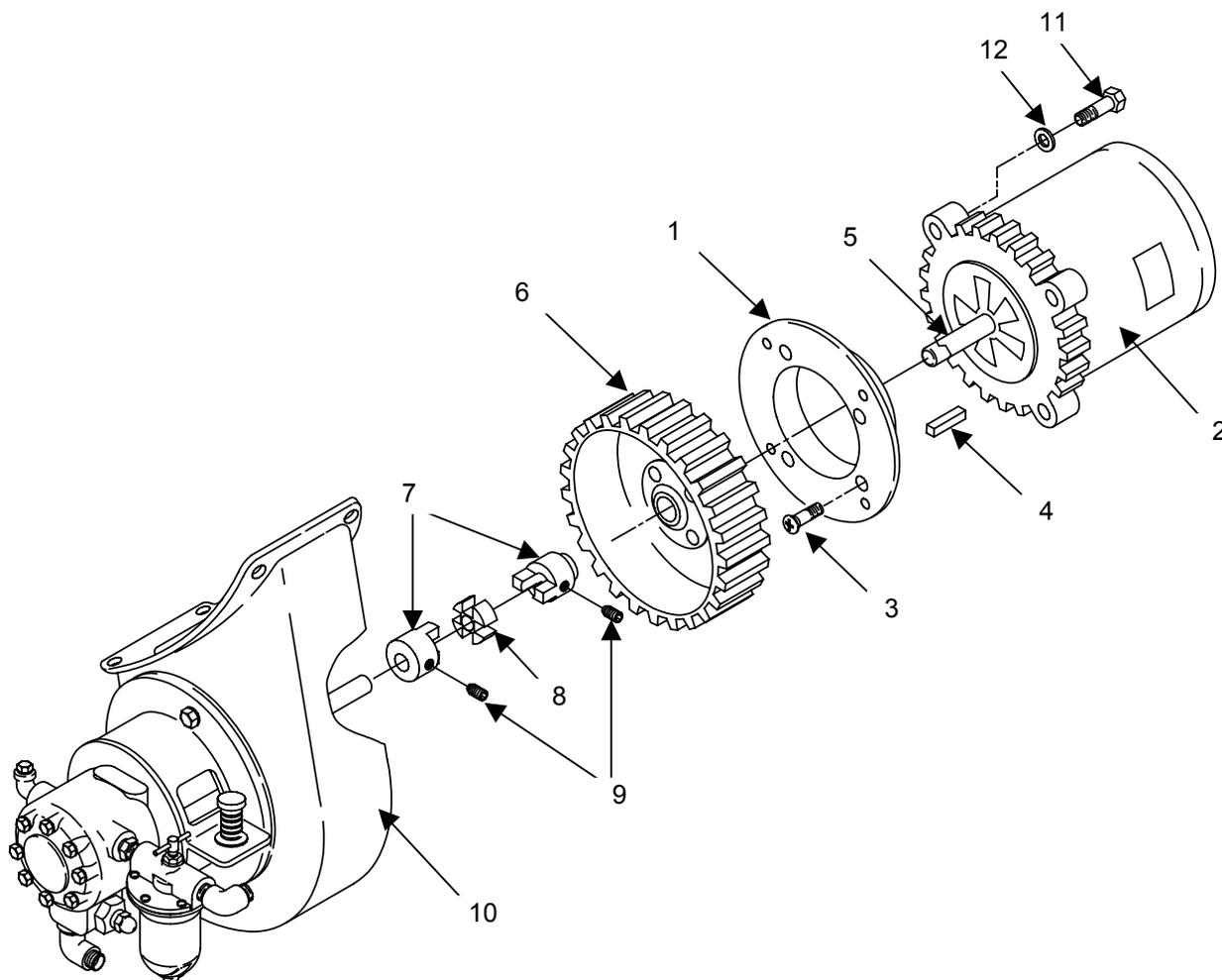
**END OF WORK PACKAGE**

DIRECT SUPPORT MAINTENANCE
HEATER, WATER, LIQUID FUEL M-80 AND M-85
NSN 4520-01-162-0385 (M-80) 4520-01-237-3719 (M-85)
FUEL PUMP ASSEMBLY
REMOVE, INSPECT, REPAIR, INSTALL

INITIAL SETUP:**Tools**

Tool Kit, General Mechanic's, Automotive (Item 3, WP 0038 00)

Personnel Required

One

Materials/Parts

Cloth, Cleaning (Item 11, WP 0057 00)
 Gasket (Item 7, WP 0057 00)
 Gasket, Cover (Item 1, WP 0057 00)
 Gasket, End Cap (Item 8, WP 0057 00)
 Gasket Port Housing (Item 5, WP 0057 00)
 Packing, Preformed (Item 12, WP 0057 00)
 Packing, Preformed (Item 13, WP 0057 00)
 Packing, Preformed (Item 14, WP 0057 00)
 Seal (Item 16, WP 0057 00)

Equipment Condition

Water heater shut off, cooled down.
 Power switch off, power cable disconnected.
 Fuel line disconnected.
 Fuel filter removed from water heater.

REMOVE**WARNING**

When disassembling the fuel pump components, avoid fuel spills. Serious injuries from igniting fuel or explosion could result.

Remove the fuel pump from the M-80 Water Heater as follows:

1. Remove two hex head screws **(1)** and two lock washers **(2)** securing fuel pump **(3)** to shutter assembly **(4)**.
2. Loosen setscrews **(5)** on coupling **(6)** and remove fuel pump **(3)**.
3. Remove elbow **(7)**, plug **(8)**, and elbow **(9)** from fuel pump **(3)**.
4. Remove pipe plugs from replacement pump and install on defective pump to protect it from dirt and foreign matter.
5. Install bypass plug for proper operation with two pipe system.

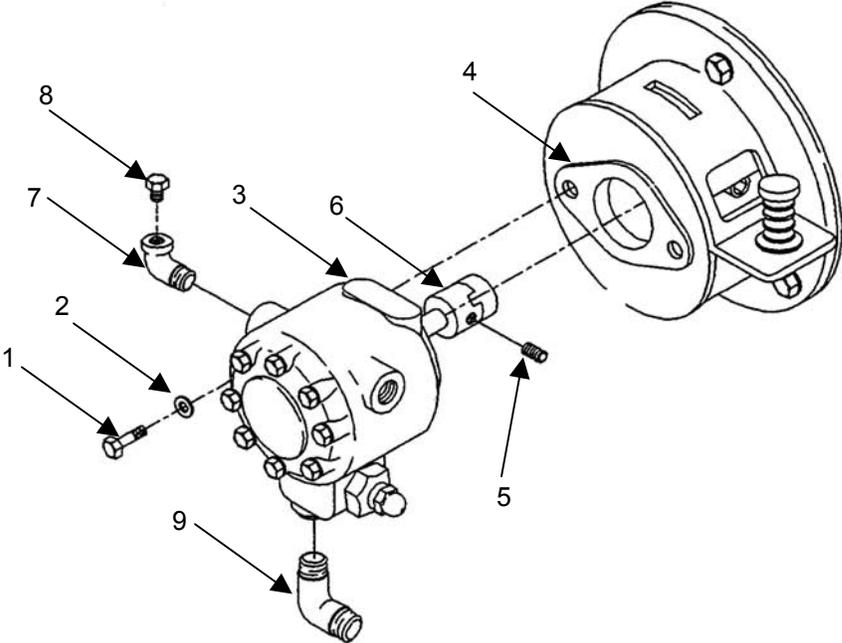
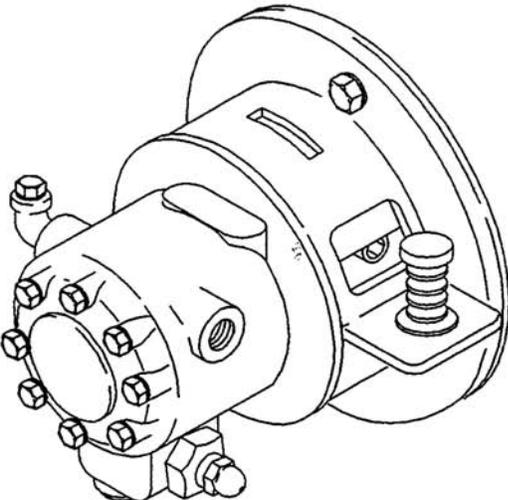

Remove the fuel pump from the M-85 Water Heater as follows:

1. Disconnect hose (1) from elbow (2)
2. Disconnect fuel line (3) from elbow (4).
3. Disconnect hose (5) from elbow (6)
4. Loosen setscrew (7) on coupling (8).
5. Remove two screws (9), lock washers (10), and fuel pump (11) from shutter assembly (12).
6. Remove elbows (2), (4), and (6) from fuel pump (11).

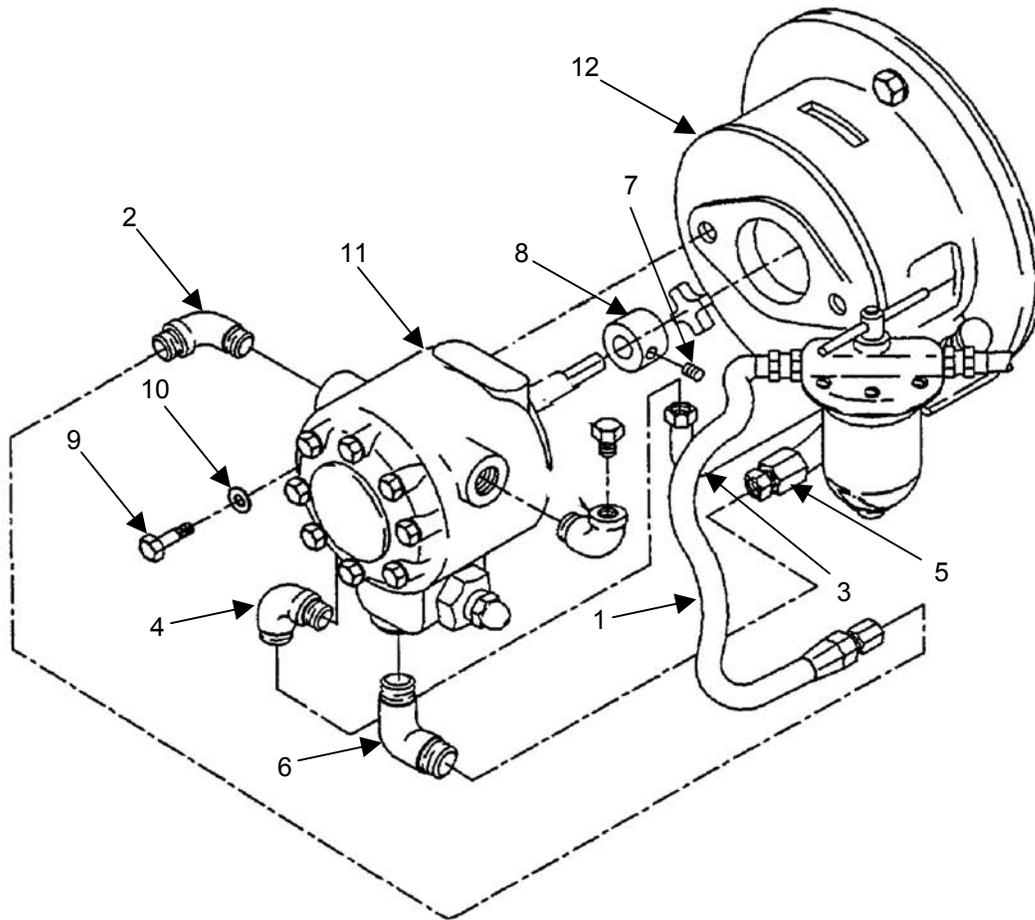

INSPECT

1. Disassemble the fuel pump as described under REPAIR.
2. Inspect for worn out, damaged, or otherwise defective parts.

REPAIR

1. To repair the fuel pump, disassemble it as described below and clean components.
2. Replace a defective component as necessary.

Fuel Pump Disassembly (M-80)

1. Remove eight screws **(1)**, cover **(2)** and cover gasket **(3)** from fuel pump.
2. Grasp strainer **(4)** by handle and pull strainer out of pump body.
3. Unscrew five gear set screws **(5)** and remove end plate assembly **(6)**.
4. With snap ring pliers remove retaining ring **(7)** and O-ring **(8)**. Press shaft assembly **(9)** from body.
5. Remove stationary face seal **(10)**, seal **(11)**, washer **(12)** and O-ring **(13)** from shaft assembly **(9)**.
6. Remove nozzle plug assembly **(14)**, gasket **(15)**, and sleeve retaining ring **(16)**.
7. Remove end plug assembly **(17, 18, 19)** and gasket **(15)**.
8. Remove spring seat **(20)**, piston spring **(21)**, and piston assembly **(22)**.
9. Press port housing **(23)** from pump body and remove port housing gasket **(24)**.
10. Remove three pipe plugs **(25)** and bypass plug **(26)**. Remove short plug **(27)**.
11. Remove washer **(28)** and piston sleeve **(29)**.

**WARNING**

Dry-cleaning solvent, P-D-680, Type III is potentially dangerous. Avoid repeated or prolonged breathing off vapors and skin contact with liquid. Do not use near open flame, arcing equipment, or other ignition sources. Use only in well ventilated area. Failure to do so may cause injury to personnel.

12. Clean all parts in solvent.

Fuel Pump Assembly (M-80)

1. Install piston sleeve (29).
2. Install three pipe plugs (25) and bypass plug (26). Install short plug (27).
3. Install port housing gasket (24) and port housing (23) by pressing in place.
4. Install piston assembly (22), piston spring (21), and spring seat (20).
5. Install end plug assembly (17, 18, 19) and gasket (15).
6. Place washer (28) into position and insert sleeve retaining ring (16), gasket (15) and nozzle plug assembly (14).
7. Install 0-ring (13), washer (12), seal (11), and stationary face seal (10) onto shaft (9).
8. Press shaft assembly (9) into body. Install 0-ring (8) and retaining ring (7) on shaft assembly (9).
9. Install end plate (6) and secure with five screws (5)
10. Push strainer (4) into pump.
11. Assemble gasket (3) and cover (2) and secure to pump body with eight screws (1).

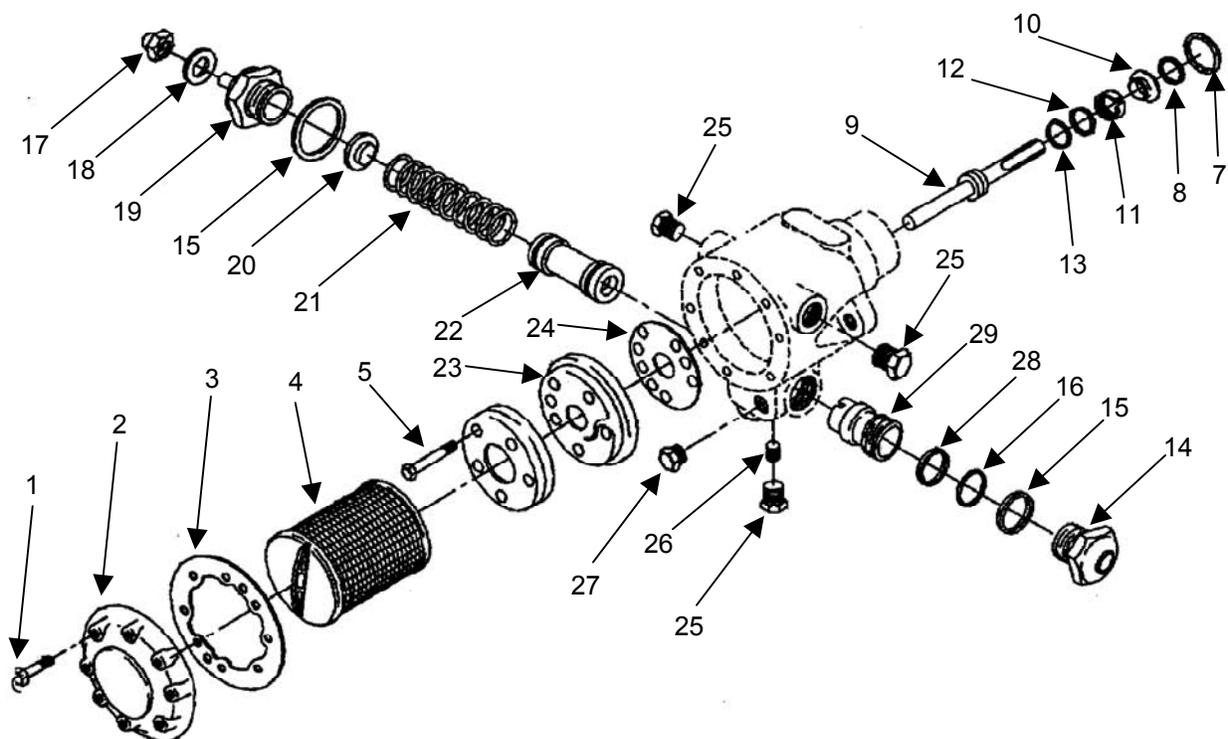

Fuel Pump Disassembly (M-85)

1. Remove eight screws **(1)**, cover **(2)** and cover gasket **(3)** from fuel pump.
2. Grasp strainer **(4)** by handle and pull strainer out. Remove diaphragm **(5)**.
3. Unscrew five gear set screws **(6)** and remove end plate assembly **(7)** with spacer.
4. Remove packing nut **(8)**, and shouldered washer **(9)**. Press shaft assembly **(10)** from body.
5. Remove spring **(11)**, O-Ring **(12)**, and shim **(13)** from shaft assembly **(10)**.
6. Remove nozzle plug **(14)**, gasket **(15)** and sleeve retainer **(16)**.
7. Remove nut **(17)**, gasket **(18)**, and screw **(19)** from end plug assembly **(20)**.
8. Remove end plug assembly **(20)**, gasket **(15)**, helical compression seat **(21)**, and spring **(22)**.
9. Push port housing **(23)** from fuel pump and remove port housing gasket **(24)**.
10. Remove the bleeder valve **(25)**, plug **(26)**, and three pipe plugs **(27)**.
11. Remove piston sleeve assembly **(28)**, consisting of two flat washers **(29)**, the piston **(30)**, and cylinder sleeve **(31)**.

**WARNING**

Dry-cleaning solvent, P-D-680, Type III is potentially dangerous. Avoid repeated or prolonged breathing off vapors and skin contact with liquid. Do not use near open flame, arcing equipment, or other ignition sources. Use only in well ventilated area.

12. Clean all parts in solvent.

Fuel Pump Assembly (M-85)

1. Install piston sleeve assembly **(28)**, consisting of two flat washers **(29)**, the piston **(30)**, and cylinder sleeve **(31)**.
2. Install the bleeder valve **(25)**, plug **(26)**, and three pipe plugs **(27)**.
3. Install port housing gasket **(24)**, and port housing **(23)** by pressing in place.
4. Install piston spring **(22)**, spring seat **(21)**, gasket **(15)**, and end plug assembly **(17, 18, 19, 20)**.
5. Install sleeve retainer **(13)**, gasket **(12)** and end plug **(11)** onto the shaft **(10)**.
6. Press shaft assembly **(10)** into body. Install O-ring **(9)** and packing nut **(8)**.
7. Install end plate **(7)** with spacer and secure with five screws **(6)**
8. Install diaphragm **(5)** and push strainer **(4)** into pump.
9. Assemble gasket **(3)** and cover **(2)** and secure to pump body with eight screws **(1)**.

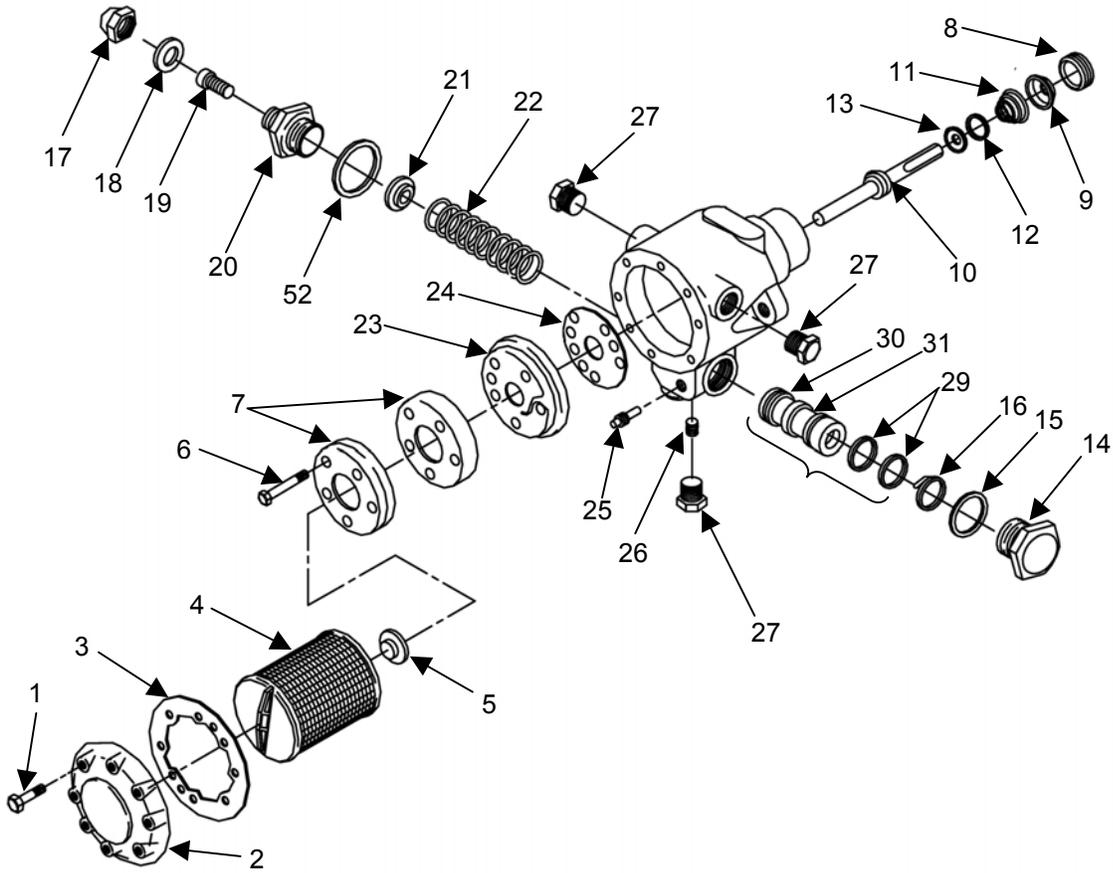

INSTALL

To install the fuel pump assembly into the M-80 Water Heater, proceed as follows:

1. Install elbows **(1)** and **(2)** on fuel pump **(3)**.
2. Install plug **(4)** on elbow **(1)**.
3. Install reducer nipple **(5)** and fuel filter **(6)** on fuel pump **(3)**.
4. Set fuel pump **(3)** in place on shutter assembly **(7)** and secure with two hex head screws **(8)** and two lock washers **(9)**.
5. Open the air band **(10)** on the shutter assembly **(7)**, and tighten setscrew **(11)** on coupling **(12)**.
6. Install fuel filter bracket as described in WP 0021 00.
7. Connect fuel lines as described in WP 0021 00.
8. Prime pump and check for leaks.

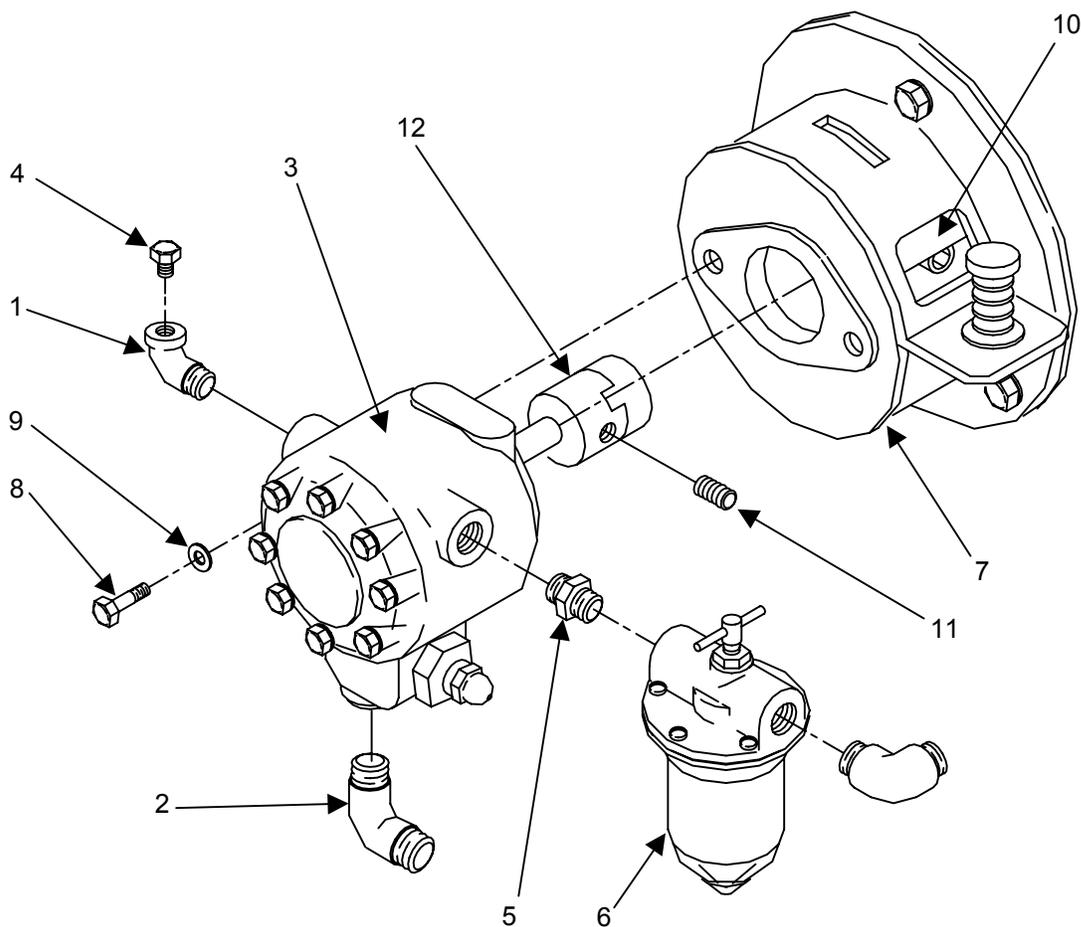

To install the fuel pump assembly into the M-85 Water Heater, proceed as follows:

1. Install elbows (1), (2), and (3) on fuel pump (4).
2. Install plug (5) in elbow (6) and install elbow in fuel pump (4).
3. Install fuel pump (4) on shutter assembly (7) and secure with two lock washers (8) and screws (9).
4. Tighten setscrew (10) on coupling (11).
5. Connect hose (12) to elbow (1).
6. Connect fuel line (13) to elbow (2).
7. Connect hose (14) to elbow (3).
8. Prime pump and check for leaks.

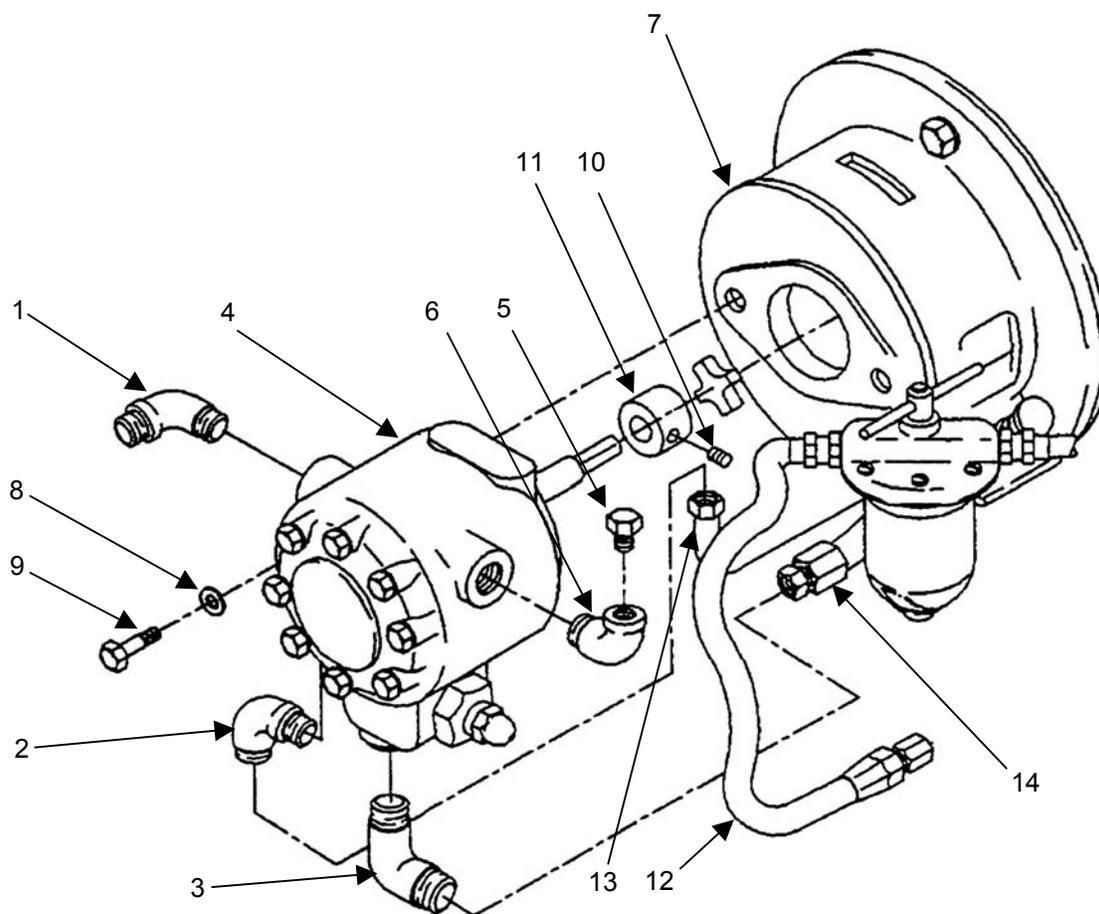

END OF WORK PACKAGE

**DIRECT SUPPORT MAINTENANCE
HEATER, WATER, LIQUID FUEL M-80 AND M-85
NSN 4520-01-162-0385 (M-80) 4520-01-237-3719 (M-85)
AIR SHUTTER ASSEMBLY
REMOVE, REPAIR, INSTALL**

INITIAL SETUP:**Tools**

Tool Kit, General Mechanic's, Automotive (Item 3, WP 0038 00)

Personnel Required

One

Materials/Parts

Cloth, Cleaning (Item 1, WP 0057 00)

Equipment Condition

Water heater shut off, cooled down.
Power switch off, power cable disconnected.

REMOVE

Remove the air shutter assembly as follows:

1. Remove fuel pump and filter assembly as described in Work Package 0032 00.
2. Remove three cap screws **(1)**, three washers **(2)**, and remove air shutter assembly **(3)** from blower **(4)**.

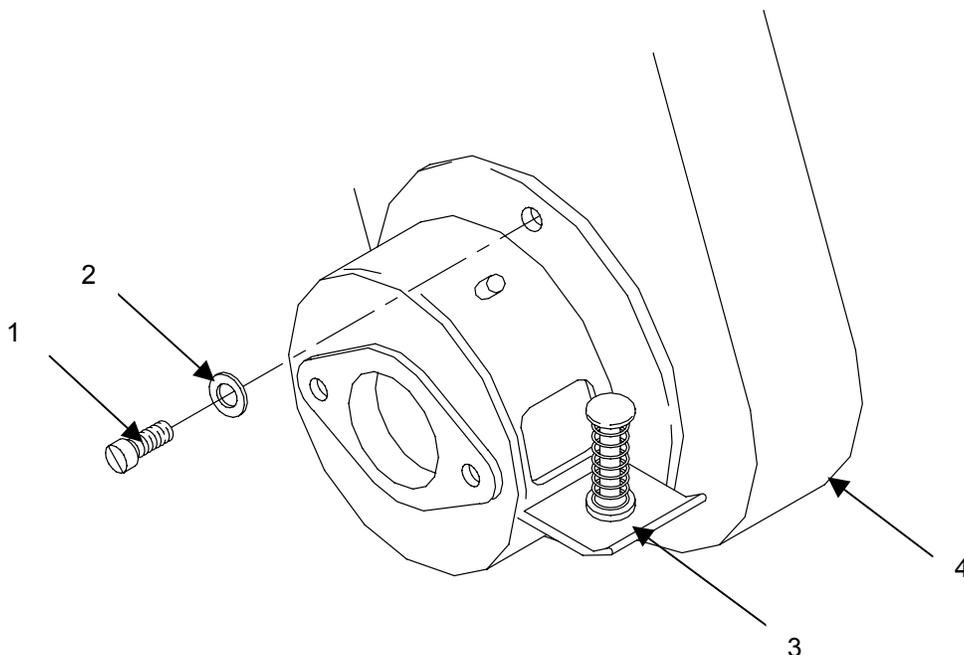

3. Remove cotter pin (5), two washers (6), spring (7), and rivet (8).
4. Remove air band (9), from the air shutter (10).

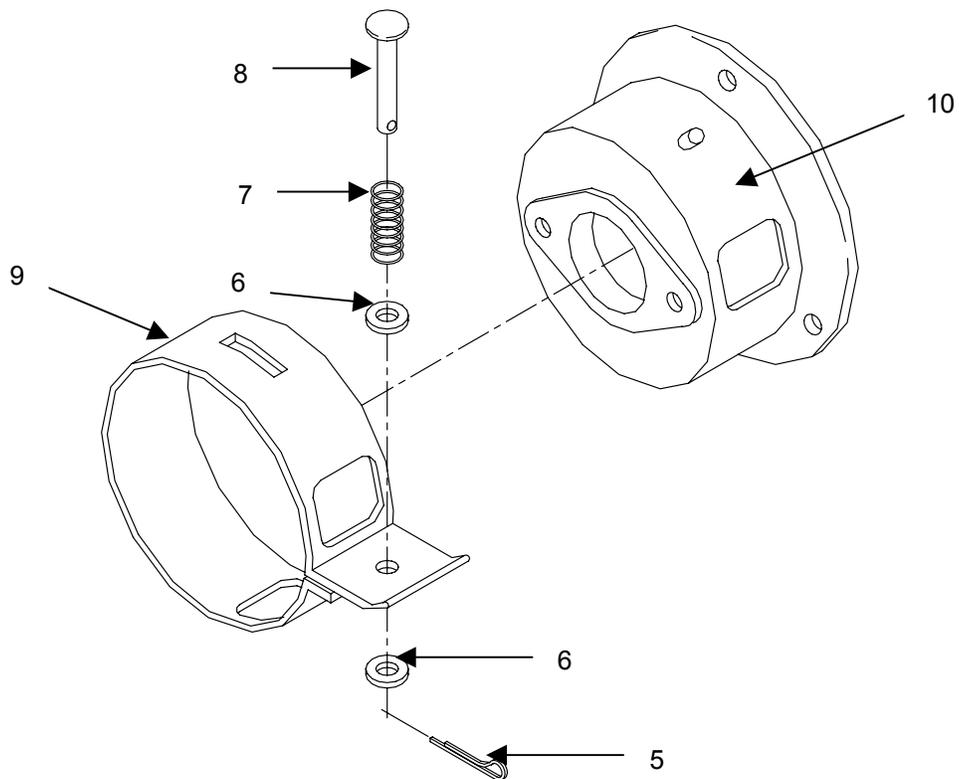

REPAIR

Repair an air shutter assembly by replacing faulty components as necessary.

INSTALL

1. Place air band (1) over shutter (2) and secure with rivet (3), spring (4), two washers (5) and cotter pin (6).
2. Position air shutter assembly (7) on blower housing (8) and secure with three cap screws (9) and three washers (10).
3. Install fuel pump and filter assembly as described in WP 0032 00.

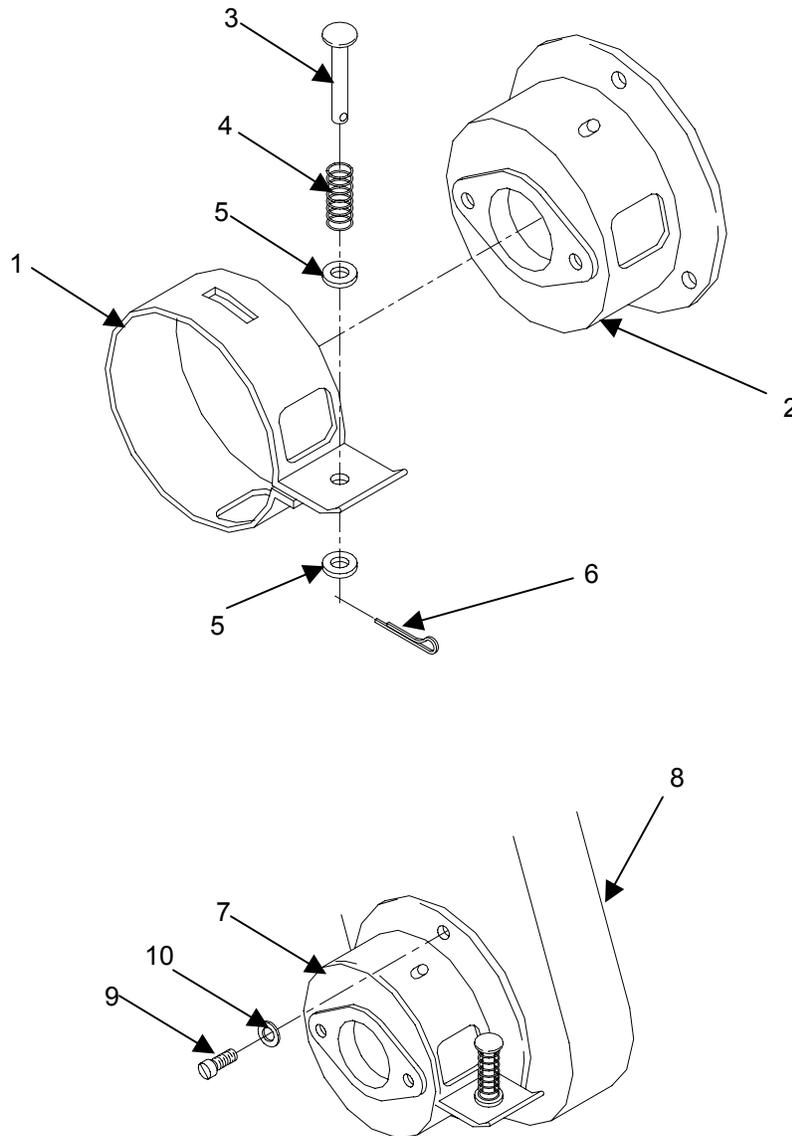
**END OF WORK PACKAGE**

**DIRECT SUPPORT MAINTENANCE
HEATER, WATER, LIQUID FUEL M-80 AND M-85
NSN 4520-01-162-0385 (M-80) 4520-01-237-3719 (M-85)
WATER VESSEL AND SKID ASSEMBLY
REMOVE, REPAIR, INSTALL**

INITIAL SETUP:**Tools**

Tool Kit, General Mechanic's, Automotive (Item 3, WP 0038 00)

Personnel Required

Two

Materials/Parts

Cloth, Cleaning (Item 1, WP 0057 00)

Compound, Cleaning (Item 3, WP 0057 00)

Primer (Item 9, WP 0057 00)

Paint (Item 8, WP 0057 00)

Solder (Item 11, WP 0057 00)

Gasket, Smoke Box Cover (Item 17, WP 0057 00)

Gasket, Blower (Item 10, WP 0057 00)

Gasket, Burner Head (Item 6, WP 0057 00)

Equipment Condition

Water heater shut off, cooled down.

Power switch off, power cable disconnected.

REMOVE

The welded water vessel and skid assembly may sustain damage during shipment and handling. Minor dents and scratches can be repaired by cleaning and coating the affected area with paint. A ruptured vessel, broken leg or bent skid can be repaired by welding. More severe damage may require replacement of the vessel. When making repairs, remove only those assemblies or parts necessary to gain access to the damaged components. Remove the following assemblies as applicable:

1. Smokestack assembly as described in WP 0020 00.
2. Fuel supply control assembly as described in WP 0018 00.
3. Burner head assembly as described in WP 0019 00.
4. Transformer box as described in WP 0021 00.
5. Conduit, electrical fittings and wiring as described in WP 0029 00.
6. Temperature high limit and operation limit controls as described in WP 0029 00.
7. Upper and lower manifold assemblies as described in WP 0025 00.
8. Instructional, identification and warning plates as necessary.
9. Ignition cables as described in WP 0021 00.
10. Blower assembly as described in WP 0030 00.
11. Low water probe assembly as described in WP 0029 00.
12. Control box assembly as described in WP 0035 00.
13. UV/IR scanner as described in WP 0027 00.
14. Remove sight assembly cap **(1)**.

15. Remove smoke box cover (2) and smoke box cover gasket (3) by removing eight nuts (4) and eight washers (5). Remove smokestack bracket. Slide smoke box cover off.
16. Remove water heater handle (6) by removing four nuts (7), eight screws (8), and four washers (9). Lift handle up.
17. Remove drain cock (10) from water vessel (11).



WARNING

The water vessel is heavy. To avoid injuries, two persons are required to lift the water vessel off the skid. Failure to comply may cause serious injury.

18. Remove water vessel (11) from skid (12) by removing seven nuts (13), seven washers (14) and seven screws (15).
19. Remove fuel line holder (16) by removing two screws (17).

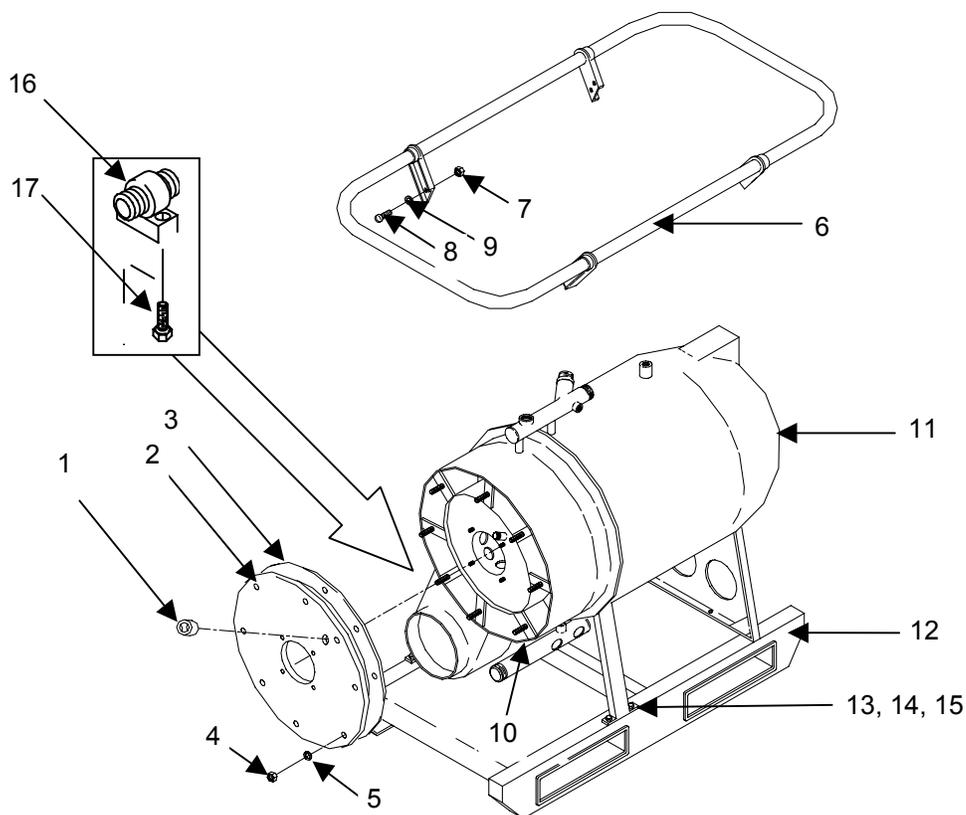

REPAIR

Make needed repairs or replace vessel or skid as necessary.

1. Weld the following components made of steel in accordance with MIL-W-52574 Type I:

Water vessel	Drum fill adapter extension
Blower duct	Handle
Burner tube	Flue support
Filter mounting bracket	Fuel line holder
Transformer mounting plate	Smoke pipe elbow assembly
Control box and cover	Smoke pipe cap and guard

2. Weld the skid assembly, made of aluminum, in accordance with MIL-W-45206 Class B.

**WARNING**

Do not apply primer or paint in an enclosed area. Avoid repeated or prolonged breathing of vapors. Apply only in well-ventilated area.

3. After welding, clean all exposed metal surfaces using cleaning compound. Then apply a coat of primer and a finish coat of enamel paint.

INSTALL

1. Install fuel line holder **(16)** and secure with two screws **(17)**.
2. Attach water vessel **(11)** to skid **(12)** using seven screws **(15)**, seven washers **(14)** and seven nuts **(13)**.
3. Install drain cock **(10)** by inserting in water vessel **(11)** and turning clockwise.
4. Install water heater handle **(6)** on water vessel **(11)** and secure with eight screws **(8)**, four washers **(9)** and four nuts **(7)**.
5. Install smoke box cover **(2)** and smoke box cover gasket **(3)** and secure with eight washers **(5)** and eight nuts **(4)**.
6. Install sight assembly cap **(1)** on sight tube.
7. Install the following assemblies as applicable:
 - a. Control box assembly as described in WP 0035 00.
 - b. Low water probe assembly as described in WP 0029 00.
 - c. UV/IR scanner as described in WP 0027 00.
 - d. Blower assembly as described in WP 0030 00.

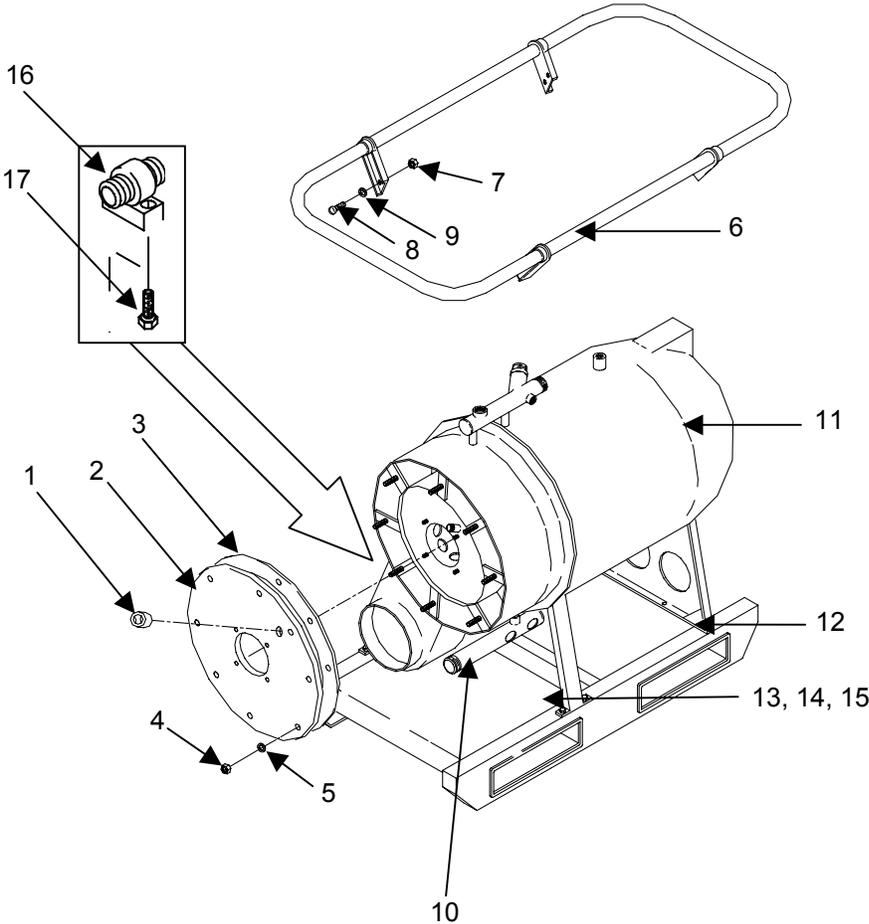

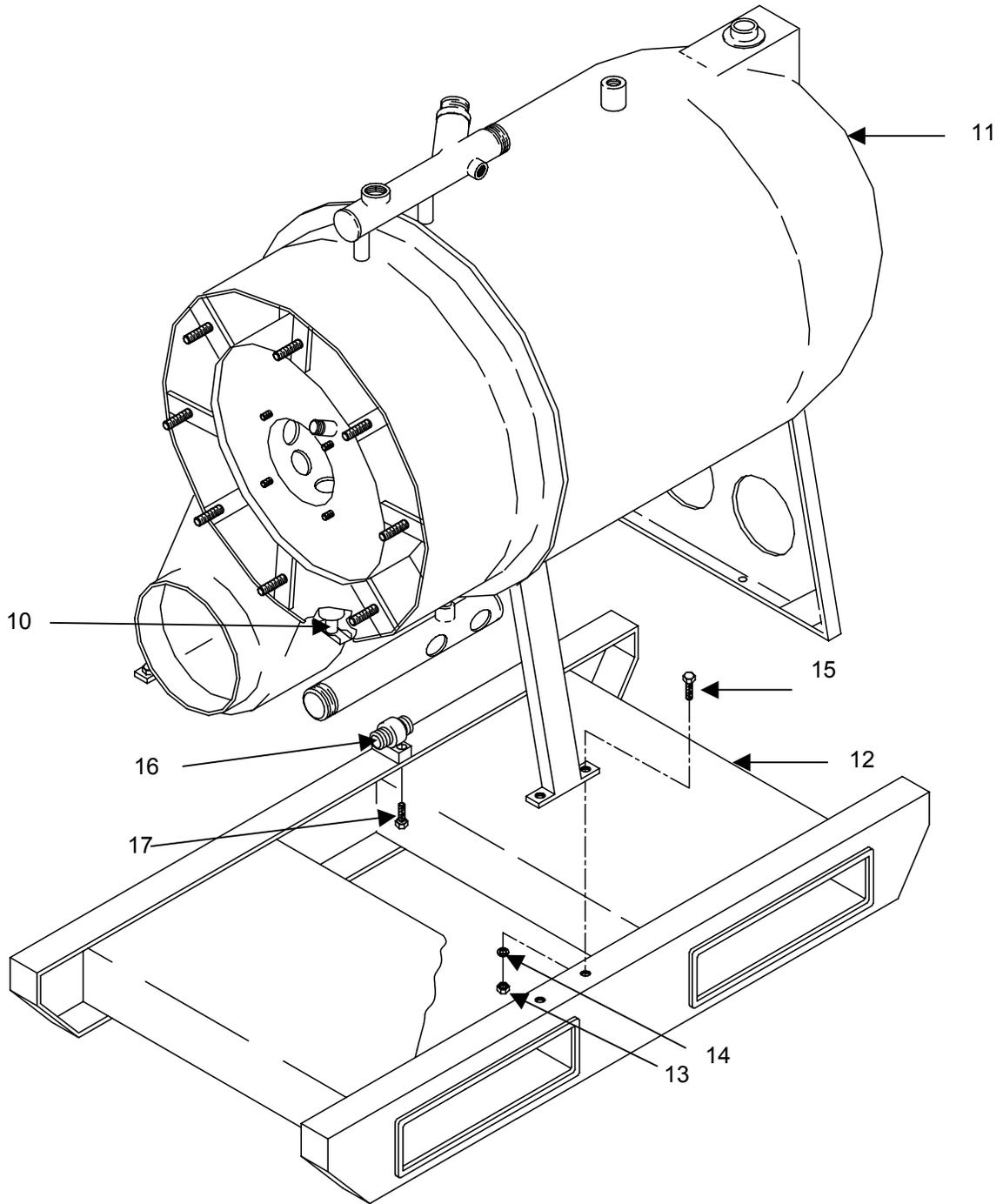

- e. Ignition cables as described in WP 0021 00.
- f. Instructional, identification and warning plates as necessary.
- g. Upper and lower manifold assemblies as described in WP 0025 00.

- h. Temperature high limit and operation limit controls as described in WP 0029 00.
- i. Conduit, electrical fittings and wiring as described in WP 0029 00.
- j. Ignition transformer as described in WP 0021 00.
- k. Burner head assembly as described in WP 0019 00.
- l. Fuel supply control assembly as described in WP 0018 00.
- m. Smokestack assembly as described in WP 0020 00.

END OF WORK PACKAGE

**DIRECT SUPPORT MAINTENANCE
HEATER, WATER, LIQUID FUEL M-80 AND M-85
NSN 4520-01-162-0385 (M-80) 4520-01-237-3719 (M-85)
CONTROL BOX ASSEMBLY
INSPECT, TEST, REMOVE, INSTALL**

INITIAL SETUP:**Tools**

Tool Kit, Electronic Equipment (Item 2, WP 0038 00)

Personnel Required

One

Materials/Parts

Cloth, Cleaning (Item 1, WP 0057 00)
Tag (Item 13, WP 0057 00)

Equipment Condition

Water heater shut off, cooled down.
Power switch off, power cable disconnected.

**WARNING**

High voltage is present on this equipment. Do not perform maintenance with power on. Death or serious injury may result.

INSPECT

1. Inspect the control box from the outside and determine any damage or corrosion.
2. Open the control box cover and inspect components. Note any damage to components, including signs of burns, frayed insulation on wires, loose wires or components.

TEST**NOTE**

It may be necessary to remove receptacle from control box to contact rear output pins.

1. Use multimeter on low ohms scale and check continuity from the front of receptacle **(1)** to rear output of each pin. Replace receptacle as described in this work package, if no continuity is indicated on any pin.

NOTE

Two different power switches may be found. One (old style) incorporates overload heaters; the other (new style) does not.

2. Check overload heaters for damage. If overload heaters are damaged, replace an old style switch with a new style switch.
3. Set power switch to off. With multimeter on high ohms scale, measure from receptacle **(1)** to input terminals of the motor contactor **(2)**. The meter should indicate an open circuit.

4. Set power switch **(3)** to **ON**. With multimeter on low ohms scale, repeat measurements in paragraph 3. The meter should indicate continuity for points connected by same color wire.
5. Replace power switch **(3)** as described under REMOVE (steps 4 through 6), and under INSTALL (steps 12 and 13), if defective.
6. With multimeter on high ohms scale, measure from the three input terminals to the three corresponding output terminals of motor contactor **(2)**. Meter should indicate an open circuit.
7. With multimeter on low ohms scale, push in motor contactor solenoid **(4)**, and repeat measurements in 6. Meter should indicate continuity.
8. Replace defective motor contactor **(2)** as described under REMOVE (steps 8 and 9); and under INSTALL (steps 8 and 9).
9. Tag and disconnect wires from terminals 1 and 2 of low water relay **(5)**.
10. With multimeter on high ohms scale, measure between terminals 1 and 2. Meter should indicate an open circuit.
11. With multimeter on high ohms scale measure between terminal 2 of low water relay **(5)** and chassis ground. Meter should indicate an open circuit.
12. If meter indicates continuity during step 10, or 11, above, replace low water relay **(5)** as described under REMOVE step 7 and INSTALL step 10.
13. Reconnect tagged wires to terminals 1 and 2 of low water relay **(5)**. Remove tags.
14. Tag and disconnect wires from terminals 9 and 10 of low water relay **(5)**.
15. Conduct measurements on terminals 9 and 10 as described in steps 10 and 11, above, for terminals 1 and 2. Meter should indicate continuity. If continuity is not indicated, replace low water relay as described under REMOVE step 7 and INSTALL step 10.
16. Turn temperature control to zero. With multimeter on high ohms scale, measure between terminals 7 and 8 of low water relay **(5)**. Meter should indicate an open circuit. If continuity is indicated, replace low water relay as described under REMOVE step 7 and INSTALL step 10.

NOTE

Turn electrical power on before performing the following tests:

17. Test function of flame safeguard control **(6)** by closing the fuel shut off valve (See Work Package 0005 00) on the water heater to simulate a low fuel and loss of flame condition. If alarm does not function, test the flame safeguard control as described in WP 0027 00.
18. If the flame control is indicating an alarm condition and buzzer is not sounding, replace buzzer as described in REMOVE and INSTALL of this work package.

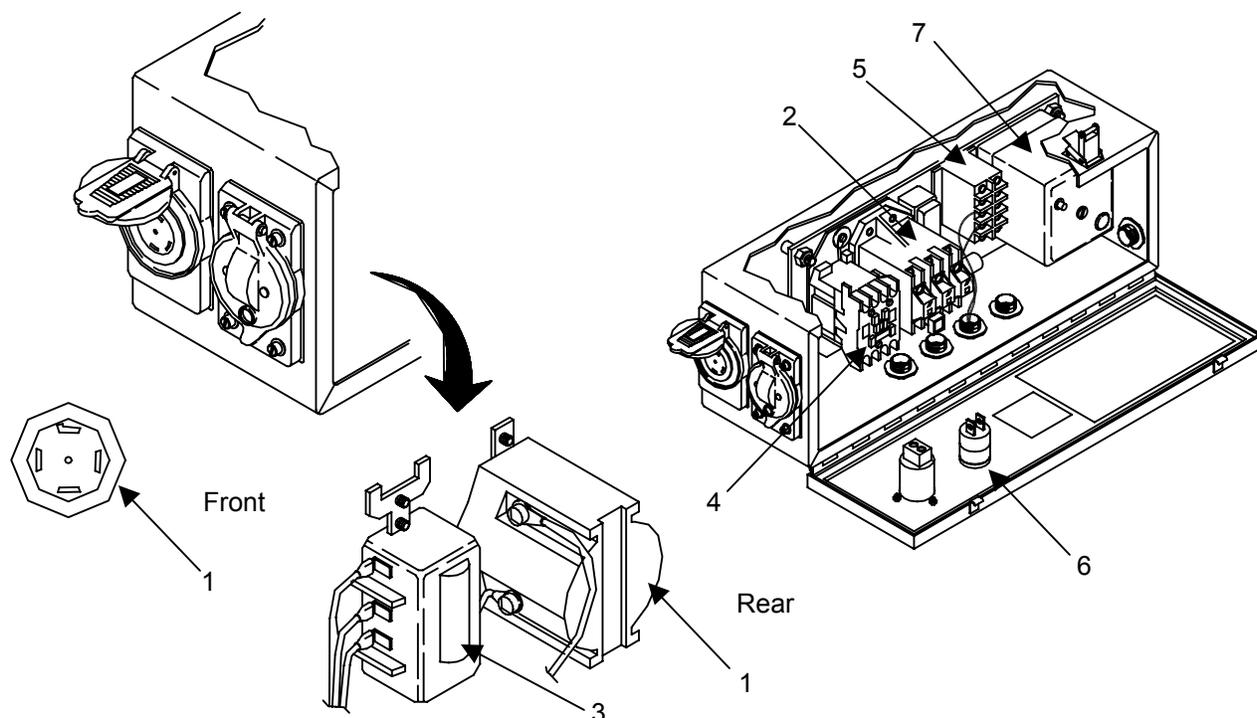

Continue testing on M-85 Water Heater Only:

19. Test the K-2 initiate relay (6-1-9976/6-1-8786) **(8)** by checking for continuity between pin 2 and 7. Multimeter should indicate low resistance.
20. Check for closed contacts between terminals 6 and 8, and 1 and 4. Multimeter should show 0 ohms.
21. Check for open contacts between terminals 5, 6 and 8, and 1 and 3. Multimeter should read infinity.
22. Replace the K-2 initiate relay if these readings are not obtained.
23. Test the K-1 post purge relay (6-1-9974/6-1-9973) **(9)** by checking for continuity between pins 2 and 5, and 6 and 10. Multimeter should indicate continuity.
24. Check for closed contacts between terminals 1 and 4, and 8 and 11. Multimeter should indicate 0 ohms.
25. Check for open contacts between terminals 1 and 3, and 9 and 11. Multimeter should indicate infinity.
26. Replace K-1 post purge relay if other readings are obtained.

NOTE

Test and replace the flame safeguard control as described in WP 0027 00.

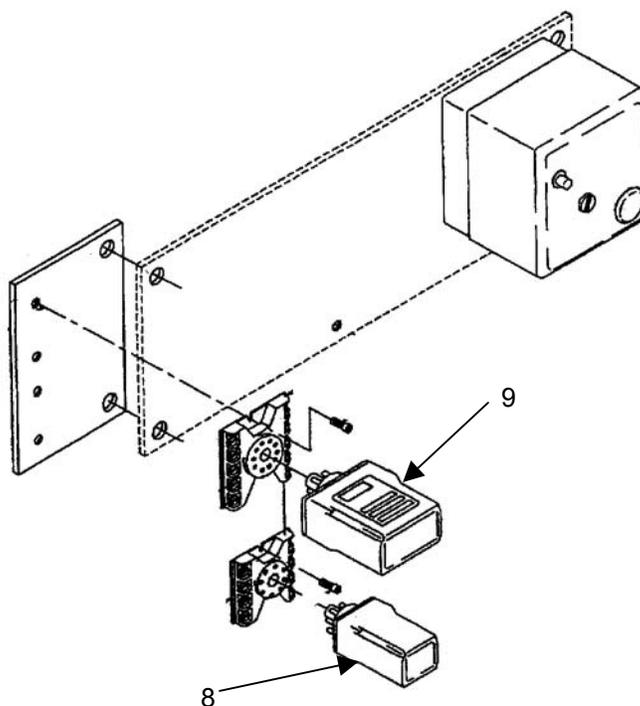

REMOVE

1. Remove receptacle (1) from control box (2), by removing four screws (3), cover plate (4) and gasket (5) and receptacle (1).
2. Tag and disconnect five wires (6) connected to the rear of the receptacle (1).
3. Remove two screws (7) and separate receptacle (1) from cover plate (4).

NOTE

Two different power switches may be found. One (old style) incorporates overload heaters (breaker), the other (new style) does not.

4. Remove the power switch cover plate (8) and gasket (9), by removing four screws (10) from the control box (2).
5. Remove the power switch (11) by removing screws (12) from the control box (2).
6. Tag all wires (13) and remove power switch (11) from control box (2).
7. Tag wires connected to low water relay (14). Remove eight screws (15) securing wire lugs to terminals. Loosen three screws (16) and raise up and remove low water relay from control box (17).

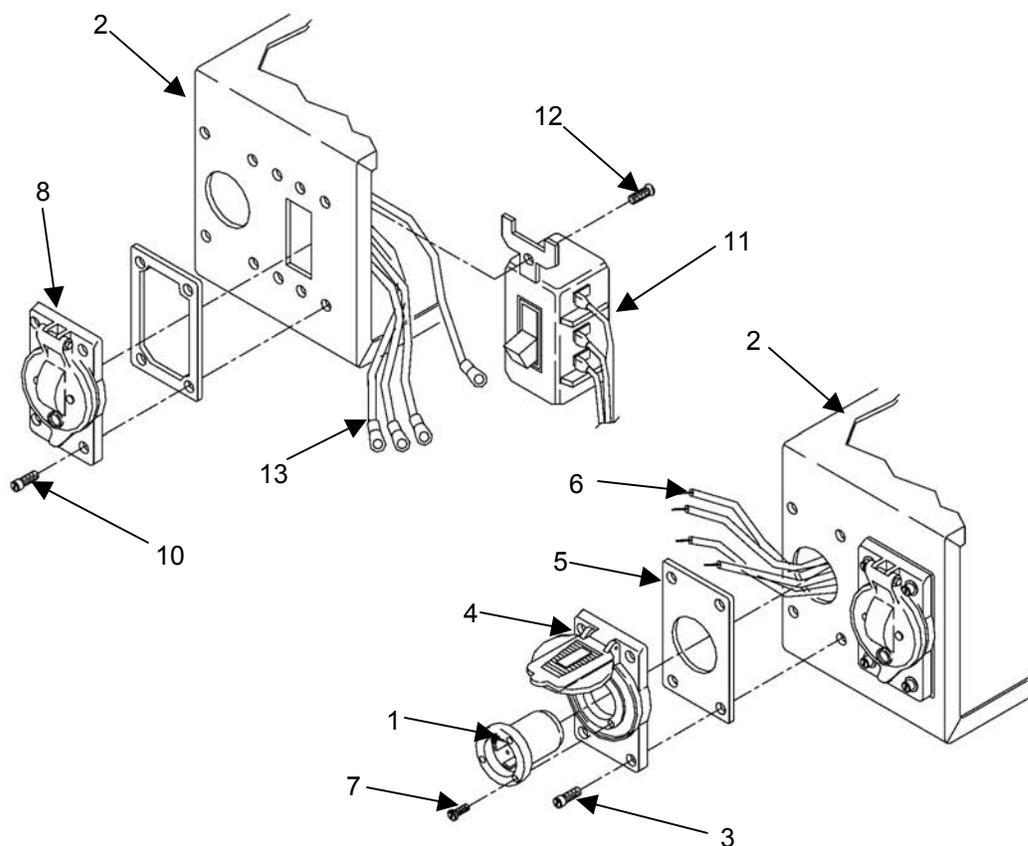

8. Tag and disconnect wires from motor contactor (18). Remove two bottom screws (19) and washers (20) and loosen top screw. Remove motor contactor from control box (17).
9. Remove six screws (21) and three contactor heaters (22).
10. Tag and disconnect two terminal lugs (23). Remove three screws (24) washers (25), nuts (26) and hour meter (27) from front of control box (17).
11. For M-85 only, tag two wires (28) on buzzer (29). Loosen two screws (30) and disconnect wires. Remove cap (31) and buzzer (29) from front of control box (17).
12. For M-80 only, tag and disconnect two wires (32) from buzzer (33). Remove two screws (34), and buzzer (33) from control box (17).
13. Tag and disconnect all wires from panel-mounted component(s).
14. Remove locknuts (35) (six on M-85 and five on M80) and conduit fitting (36) from control box (17).
15. Remove four nuts (37), lockwasher (38), screws (39), and control box (17) from skid assembly.
16. Remove four nuts (40), spacers (41), and mounting panel (42), from control box (17).

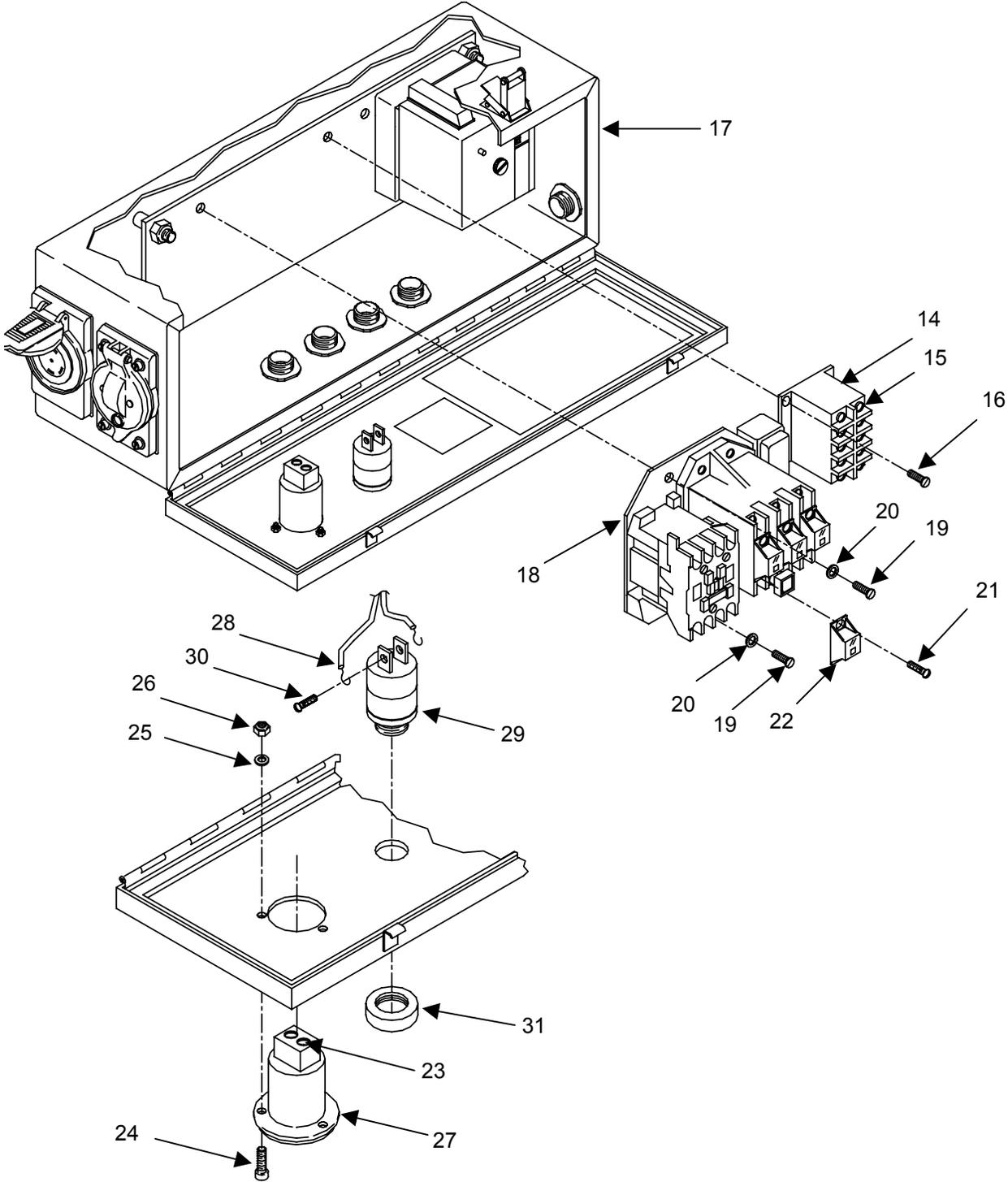

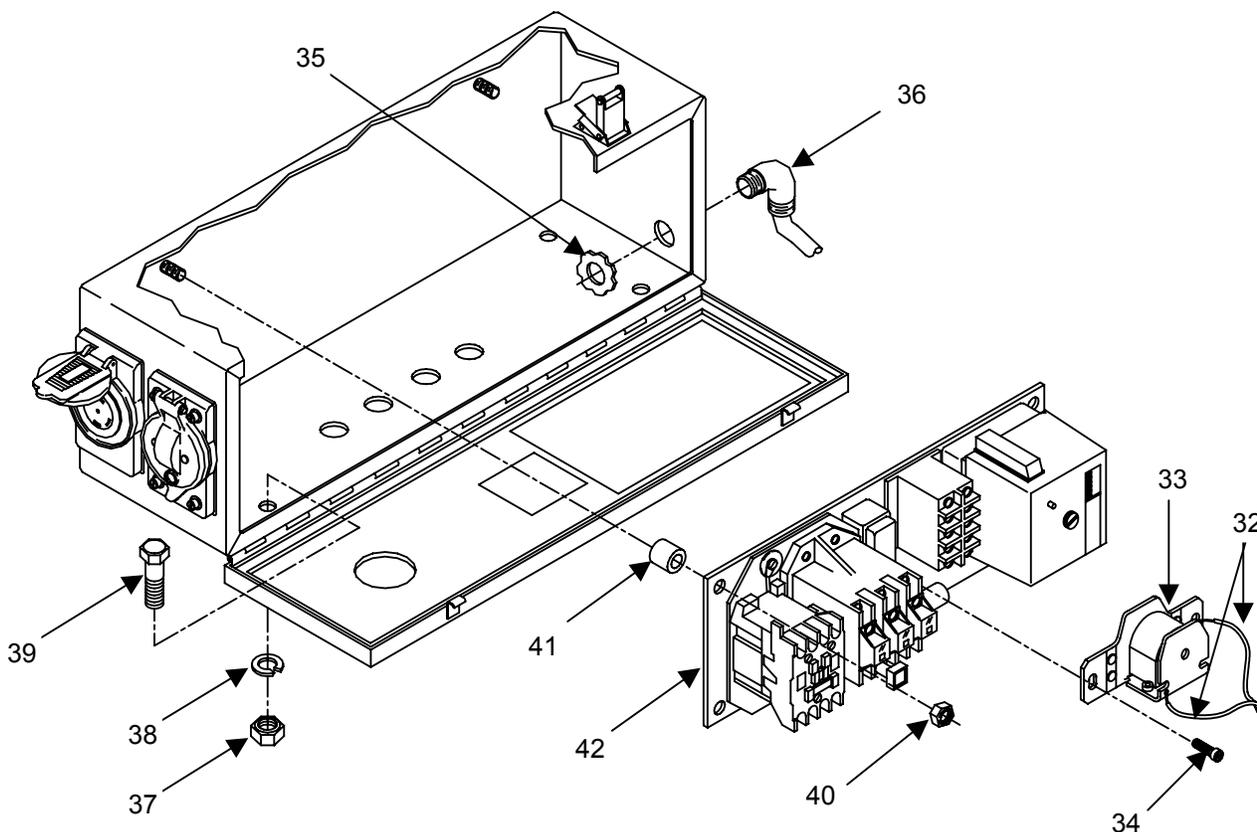

INSTALL

1. Install mounting panel (42), four spacers (41), and four nuts (40) to control box (17).
2. Install control box (17), four screws (39), lockwashers (38), and nuts (37) on skid assembly
3. Install six conduit fittings (36) (M-85), or five conduit fittings (M-80), and locknuts (35) in control box (17).
4. Connect all wires to panel-mounted components. Remove tags.
5. For M-85, install buzzer (29) and cap (31) on control box (17). Connect and secure two wires (28) with two screws (30).
6. For M-80, install leads (32) to buzzer (33). Secure with two screws. Install on control box (17) with two screws (34).
7. Install hour meter (27), three screws (24), washers (25) and nuts (26) on control box (17).
8. Install three contactor heaters (22) and secure with six screws (21).
9. Install motor contactor (18) and three screws (19) and washers (20) on control box, reconnect leads as tagged.
10. For M-80, install low water relay (14) and tighten three screws (16). Connect wire lugs to terminals with eight screws (15). Remove tags. For M-85, plug in new relay.
11. Connect wires (13) to power switch (11) and secure with screws. Remove tags.

NOTE

Two different power switches may be found. One (old style) incorporates overload heaters (breakers), the other (new style) does not. Replace an old style switch only with a new style.

12. Install power switch **(11)** with two screws **(12)** on control box **(17)**.
13. Position gasket **(9)** and cover plate **(8)** in place and secure with four screws **(10)**.
14. Install receptacle by connecting four wires **(6)** to rear of receptacle **(1)**. Remove tags.
15. Insert receptacle **(1)** through gasket **(5)** and cover plate **(4)** inside control box **(2)** and secure with three screws **(7)** under receptacle cap.
16. Secure cover plate **(4)** and gasket **(5)** with four screws **(3)**.

END OF WORK PACKAGE

CHAPTER 9

SUPPORTING INFORMATION
FOR
M-80 AND M-85 LIQUID FUEL WATER HEATER

**HEATER, WATER, LIQUID FUEL, M-80 AND M-85
REFERENCES**

SCOPE

This work package lists field manuals, forms, technical manuals and miscellaneous publications referenced in this manual or otherwise relevant to the employment of the M-80 or M-85 Water Heater.

ARMY REGULATIONS

Army Logistics Readiness and Sustainability.....AR 700-138

PAMPHLETS

Functional Users Manual for the Army Maintenance Management System - Aviation (TAMMS-A) DA PAM 738-751
The Army Maintenance Management System (TAMMS) User's Manual..... DA PAM 750-8

FIELD MANUALS

Decontamination Procedures FM 3-5
Mountain Operations FM 3-97.6
First Aid FM 4-25.11
Basic Cold Weather Manual FM 31-70
Northern Operations FM 31-71

FORMS

Discrepancy in Shipment Report.....SF 361
Equipment Inspection and Maintenance Worksheet DA Form 2404
Product Quality Deficiency ReportSF 368
Recommended Changes to Equipment Technical PublicationsDA Form 2028-2
Report of Discrepancy..... SF 364
Report of Packaging and Handling DeficienciesSF 362

TECHNICAL MANUALS

Procedures for the Destruction of Aviation Ground Support Equipment to Prevent Enemy Use..... TM 750-244-1-3
Procedures for Destruction of Equipment to Prevent Enemy Use TM 750-244-3
Operator's Manual, Laundry Unit, Trailer Mounted Model M85, M85-100, and M85-200 TM 10-3510-222-10
Unit, Direct Support, and General Support Maintenance Manual Laundry Unit, Trailer Mounted, Model M85, M85-100, M85-200 TM 10-3510-222-24
Repair Parts and Special Tools List Laundry Unit, Trailer Mounted, Model M85, M85-100, M85-200..... TM 10-3510-222-24P

TECHNICAL BULLETINS

Warranty Program for Laundry Unit, Trailer Mounted, Model M85-100 TB 10-3510-220-24

TRAINING CIRCULAR

Preservation, Packaging, and Packing of Military Supplies and Equipment TC 38-3
Metal Body Repair and Related Operations TC 9-510
Welding: Theory and Application TC 9-237

UNIT MAINTENANCE**HEATER, WATER, LIQUID FUEL, M-80, M-85
MAINTENANCE ALLOCATION CHART (MAC), INTRODUCTION****INTRODUCTION****The Army Maintenance System MAC**

This introduction provides a general explanation of all maintenance and repair functions authorized at the two maintenance levels under the Two-Level Maintenance System concept.

The MAC (immediately following the introduction) designates overall authority and responsibility for the performance of maintenance functions on the identified end item or component. The application of the maintenance functions to the end item or component shall be consistent with the capacities and capabilities of the designated maintenance levels, which are shown on the MAC in column (4) as:

Field – includes two columns, Unit maintenance and Direct Support maintenance. The Unit maintenance column is divided again into two more subcolumns, C for Operator or Crew and O for Unit maintenance.

Sustainment – includes two subcolumns, General Support (H) and Depot (D).

The tools and test equipment requirements (immediately following the MAC) list the tools and test equipment (both special tools and common tool sets) required for each maintenance function as referenced from the MAC.

The remarks (immediately following the tools and test equipment requirements) contain supplemental instructions and explanatory notes for a particular maintenance function.

Maintenance Functions

Maintenance functions are limited to and defined as follows:

1. Inspect. To determine the serviceability of an item by comparing its physical, mechanical, and/or electrical characteristics with established standards through examination (e.g., by sight, sound, or feel.) This includes scheduled inspection and gagings and evaluation of cannon tubes.
2. Test. To verify serviceability by measuring the mechanical, pneumatic, hydraulic, or electrical characteristics of an item and comparing those characteristics with prescribed standards on a scheduled basis, i.e., load testing of lift devices and hydrostatic testing of pressure hoses.
3. Service. Operations required periodically to keep an item in proper operating condition, e.g., to clean (includes decontaminate, when required), to preserve, to drain, to paint, or to replenish fuel, lubricants, chemical fluids, or gases. This includes scheduled exercising and purging of recoil mechanisms. The following are examples of service functions:
 - a. Unpack. To remove from packing box for service or when required for the performance of maintenance operations.
 - b. Repack. To return item to packing box after service and other maintenance operations.
 - c. Clean. To rid the item of contamination.
 - d. Touch up. To spot paint scratched or blistered surfaces.
 - e. Mark. To restore obliterated identification.

4. Adjust. To maintain or regulate, within prescribed limits, by bringing into proper or position, or by setting the operating characteristics to specified parameters.
5. Align. To adjust specified variable elements of an item to bring about optimum or desired performance
6. Calibrate. To determine and cause corrections to be made or to be adjusted on instruments of test, measuring, and diagnostic equipment used in precision measurement. Consists of comparisons of two instruments, one of which is a certified standard of known accuracy, to detect and adjust any discrepancy in the accuracy of the instrument being compared.
7. Remove/Install. To remove and install the same item when required to perform service or other maintenance functions. Install may be the act of emplacing, seating, or fixing into position a spare, repair part, or module (component or assembly) in a manner to allow the proper functioning of an equipment or system.
8. Paint. To prepare and spray color coats of paint so that the ammunition can be identified and protected. The color indicating primary use is applied, preferably, to the entire exterior surface as the background color of the item. Other markings are to be repainted as original so as to retain proper ammunition identification.
9. Replace. To remove an unserviceable item and install a serviceable counterpart in its place. "Replace" is authorized by the MAC and assigned maintenance level is shown as the third position code of the Source, Maintenance and Recoverability (SMR) code.
10. Repair. The application of maintenance services, including fault location/troubleshooting, removal/installation, disassembly/assembly procedures and maintenance actions to identify troubles and restore serviceability to an item by correcting specific damage, fault, malfunction, or failure in a part, subassembly, module (component or assembly), end item, or system.

NOTE

The following definitions are applicable to the "repair" maintenance function:

Services. Inspect, test, service, adjust, align, calibrate, and/or replace.

Fault location/troubleshooting. The process of investigating and detecting the cause of equipment malfunctioning; the act of isolating a fault within a system or Unit Under Test (UUT).

Disassembly/assembly. The step-by-step breakdown (taking apart) of a spare/functional group coded item to the level of its least component, that is assigned an SMR code for the level of maintenance under consideration (i.e., identified as maintenance significant).

Actions. Welding, grinding, riveting, straightening, facing, machining, and/or resurfacing.

11. Overhaul. That maintenance effort (service/action) prescribed to restore an item to a completely serviceable/operational condition as required by maintenance standards in appropriate technical publications. Overhaul is normally the highest degree of maintenance performed by the Army. Overhaul does not normally return an item to like new condition.

12. Rebuild. Consists of those services/actions necessary for the restoration of unserviceable equipment to a like new condition in accordance with original manufacturing standards. Rebuild is the highest degree of material maintenance applied to Army equipment. The rebuild operation includes the act of returning to zero those age measurements (e.g., hours/miles) considered in classifying Army equipment/components.

Explanation of Columns in the MAC

Column (1) Group Number. Column (1) lists Functional Group Code (FGC) numbers, the purpose of which is to identify maintenance significant components, assemblies, subassemblies, and modules with the Next Higher Assembly (NHA).

Column (2) Component/Assembly. Column (2) contains the item names of components, assemblies, subassemblies, and modules for which maintenance is authorized.

Column (3) Maintenance Function. Column (3) lists the functions to be performed on the item listed in column (2). (For a detailed explanation of these functions refer to "Maintenance Functions" outlined above).

Column (4) Maintenance Level. Column (4) specifies each level of maintenance authorized to perform each function listed in column (3), by indicating work time required (expressed as manhours in whole hours or decimals) in the appropriate subcolumn. This work time figure represents the active time required to perform that maintenance function at the indicated level of maintenance. If the number or complexity of the tasks within the listed maintenance function varies at different maintenance levels, appropriate work time figures are to be shown for each level. The work time figure represents the average time required to restore an item (assembly, subassembly, component, module, end item, or system) to a serviceable condition under typical field operating conditions. This time includes preparation time (including any necessary disassembly/assembly time), troubleshooting/fault location time, and quality assurance time in addition to the time required to perform the specific tasks identified for the maintenance functions authorized in the MAC. The symbol designations for the various maintenance levels are as follows:

Field:

- C Operator or Crew maintenance
- O Unit maintenance
- F Direct Support maintenance

Sustainment:

- L Specialized Repair Activity
- H General Support maintenance
- D Depot maintenance

NOTE

The "L" maintenance level is not included in column (4) of the MAC. Functions to this level of maintenance are identified by work time figure in the "H" column of column (4), and an associated reference code is used in the REMARKS column (6). This code is keyed to the remarks and the SRA complete repair application is explained there.

Column (5) Tools and Equipment Reference Code. Column (5) specifies, by code, those common tool sets (not individual tools), common Test, Measurement and Diagnostic Equipment (TMDE), and special tools, special TMDE, and support special equipment required to perform the designated function. Codes are keyed to the entries in the tools and test equipment table.

Column (6) Remarks Code. When applicable, this column contains a letter code, in alphabetic order, which is keyed to the remarks table entries.

Explanation of Columns in the Tools and Test Equipment Requirements

Column (1) – Tool or Test Equipment Reference Code. The tool or test equipment reference code correlates with a code used in column (5) of the MAC.

Column (2) – Maintenance Level. The lowest level of maintenance authorized to use the tool or test equipment.

Column (3) – Nomenclature. Name or identification of the tool or test equipment.

Column (4) – National Stock Number (NSN). The NSN of the tool or test equipment.

Column (5) – Tool Number. The manufacturer's part number.

Explanation of Columns in Remarks

Column (1) - Remarks Code. The code recorded in Column (6) of the MAC.

Column (2) - Remarks. This column lists information pertinent to the maintenance function being performed as indicated in the MAC.

**UNIT MAINTENANCE
HEATER, WATER, LIQUID FUEL, M-80, M-85
MAINTENANCE ALLOCATION CHART (MAC), INTRODUCTION**

Table 1. Maintenance Allocation Chart (MAC) for Heater, Water, Liquid Fuel M-80 and M-85.

(1) GROUP NUMBER	(2) COMPONENT/ ASSEMBLY	(3) MAINTENANCE FUNCTION	(4) MAINTENANCE LEVEL					(5) TOOLS AND EQUIPMENT REFERENCE CODE	(6) REMARKS CODE
			FIELD		SUSTAINMENT				
			UNIT		DIRECT SUPPORT	GENERAL SUPPORT	DEPOT		
			C	O	F	H	D		
00	HEATER, WATER, LIQUID FUEL M-80 AND M-85								
01	FUEL SUPPLY COMPONENTS	Inspect Remove Repair Install	0.1	0.1 0.2 0.5 0.4				3, 4 3, 4 3, 4	
02	BURNER HEAD ASSEMBLY	Inspect Remove Service Repair Install		0.1 0.3 0.2 0.5 0.4				3 3 3 3	
03	SMOKESTACK AND GUARD ASSEMBLY, M-80/EXHAUST DUCT, M-85	Inspect Remove Install	0.1	0.1 0.1 0.1				3 3	
04	IGNITION TRANSFORMER AND CABLE ASSEMBLIES	Inspect Remove Test Install		0.1 0.5 0.5 0.5				3 1 3	
0401	ELECTRICAL COMPONENTS	Inspect Test Remove Install	0.1		0.2 0.2 0.3			1 3 3	
05	BLOWER ASSEMBLY	Inspect Service Remove Adjust Repair Install	0.1 0.2 0.2	0.1	0.1 0.5 3.0 1.5			3 3 3 3 3	
0501	BLOWER AND FUEL PUMP MOTOR	Remove Inspect Repair Install			0.5 0.2 1.0 0.5			3 3 3 3	
0502	FUEL FILTER ASSEMBLY	Inspect Remove Repair Install		0.1 0.2 0.2 0.3				3 3 3	
0503	FUEL PUMP	Service Inspect Adjust Remove Repair Install		0.1 0.2 0.2	0.4 0.1 0.4			3 3 3	
0504	AIR SHUTTER	Inspect Remove Repair Install		0.1	0.2 0.1 0.3			3 3 3	

Table 1. Maintenance Allocation Chart (MAC) for Heater, Water, Liquid Fuel M-80 and M-85—Continued.

(1) GROUP NUMBER	(2) COMPONENT/ ASSEMBLY	(3) MAINTENANCE FUNCTION	(4) MAINTENANCE LEVEL					(5) TOOLS AND EQUIPMENT REFERENCE CODE	(6) REMARKS CODE
			FIELD		SUSTAINMENT				
			UNIT		DIRECT SUPPORT	GENERAL SUPPORT	DEPOT		
			C	O	F	H	D		
06	WATER VESSEL AND SKID ASSEMBLY	Inspect	0.1	0.1					
		Remove			0.2			3	
		Repair	0.2		1.5			3, 4	
		Install			1.0			3	
0601	UPPER AND LOWER MANIFOLD ASSEMBLY	Inspect		0.1					
		Remove		0.2				3, 4	
		Repair		0.2				3, 4	
		Replace		0.2				3, 4	
07	UV AND IR FLAME SAFEGUARD CONTROL	Inspect		0.2					
		Test			0.4			2	
		Remove			0.5			3	
		Repair			0.2			3	
		Install			0.5			3	
08	CONTROL BOX ASSEMBLY	Inspect			0.3				
		Test			0.9			2	
		Remove			0.7			3	
		Repair			1.5			2	
		Install			0.8			3	
09	DRUM FILL ADAPTER ASSEMBLY/ TYPE II	Inspect		0.2				3	
		Repair		0.3				3	

Table 2. Tools and Test Equipment for Heater, Water, Liquid, Fuel M-80 and M-85.

(1) TOOL OR TEST EQUIPMENT REFERENCE CODE	(2) MAINTENANCE LEVEL	(3) NOMENCLATURE	(4) NATIONAL STOCK NUMBER	(5) TOOL NUMBER
1	O	Multimeter		
2	O	Tool Kit, Electronic Equipment	5180-01-460-9328	SC 5180-91-R64
3	O	Tool Kit, General Mechanics, Automotive	5180-00-177-7033	SC 5180-90-CL-N26
4	O	Tool Kit Org, Maintenance Common No. 1	4910-00-754-0654	SC 4910-95-A74

Table 3. Remarks for Heater, Water, Liquid Fuel, M-80 and M-85.

(1) REMARKS CODE	(2) REMARKS

**UNIT AND DIRECT SUPPORT MAINTENANCE
HEATER, WATER, LIQUID FUEL M-80 AND M-85
(NSN 4520-01-162-0385 (M-80) 4520-01-237-3719 (M-85))
REPAIR PARTS AND SPECIAL TOOLS LIST (RPSTL), INTRODUCTION**

INTRODUCTION**SCOPE**

This RPSTL lists and authorizes spares and repair parts; special tools; special test, measurement and diagnostic equipment (TMDE); and other special support equipment required for performance of unit and direct support maintenance of the M-80 / M-85 Water Heater. It authorizes the requisitioning, issue, and disposition of spares, repair parts, and special tools as indicated by the source, maintenance, and recoverability (SMR) codes.

GENERAL

In addition to the Introduction work package, this RPSTL is divided into the following work packages.

1. **Repair Parts List Work Packages.** Work packages containing lists of spares and repair parts authorized by this RPSTL for use in the performance of maintenance. These work packages also include parts which must be removed for replacement of the authorized parts. Parts lists are composed of functional groups in ascending alphanumeric sequence, with the parts in each group listed in ascending figure and item number sequence. Sending units, brackets, filters, and bolts are listed with the component they mount on. Bulk materials are listed by item name in FIG. BULK at the end of the work packages. Repair parts kits are listed separately in their own functional group and work package. Repair parts for repairable special tools are also listed in a separate work package. Items listed are shown on the associated illustrations.
2. **Special Tools List Work Packages.** Work packages containing lists of special tools, special TMDE, and special support equipment authorized by this RPSTL (as indicated by Basis of Issue (BOI) information in the DESCRIPTION AND USABLE ON CODE (UOC) column). Tools that are components of common tool sets and/or Class VII are not listed.
3. **Cross-Reference Indexes Work Packages.** There are two cross-reference indexes work packages in this RPSTL: The National Stock Number (NSN) Index and the Part Number(P/N) Index. The National Stock Number Index work package refers you to the figure and the item number. The Part Number Index work package refers you to the figure and the item number.

EXPLANATION OF COLUMNS IN THE REPAIR PARTS LIST AND SPECIAL TOOLS LIST WORK PACKAGES

ITEM NO. (Column (1)). Indicates the number used to identify items called out in the illustration.

SMR CODE (Column (2)). The SMR code containing supply/requisitioning information, maintenance level authorization criteria and disposition instruction, as shown in the following breakout:

<u>Source Code</u>	<u>Maintenance Code</u>	<u>Recoverability Code</u>	
---- XX ----	---- X X ----	----	----
1st two positions: How to get an item.	3rd position: Who can install, replace or use the item.	4th position: Who can do complete repair* on the item.	5th position: Who determines disposition action on unserviceable items.

* Complete Repair: Maintenance capacity, capability, and authority to perform all corrective maintenance tasks of the "Repair" function in a use/user environment in order to restore serviceability to a failed item.

Source Code. The source code tells you how to get an item needed for maintenance, repair, or overhaul of an end item/equipment. Explanations of source codes follow:

<u>Source Code</u>	<u>Explanation</u>
PA	Stock items; use the applicable NSN to requisition/request items with these source codes. They are authorized to the level indicated by the code entered in the 3rd position of the SMR code.
PB	
PC	
PD	
PE	
PF	NOTE Items coded PC are subject to deterioration.
PG	Items with these codes are not to be requested/requisitioned individually. They are part of a kit which is authorized to the maintenance level indicated in the 3rd position of the SMR code. The complete kit must be requisitioned and applied.
KD	
KF	
KB	
MO-Made at Unit/ AVUM Level	Items with these codes are not to be requisitioned/requested individually. They must be made from bulk material which is identified by the P/N in the DESCRIPTION AND USABLE ON CODE (UOC) column and listed in the bulk material group work package of the MF-Made at DS/ AVIM Level MH-Made at GSRPSTL. If the item is authorized to you by the 3rd position Level ML-Made at SRA MD-Made at Depot
MF-Made at DS/ AVIM Level	
MH-Made at GSRPSTL. Level	
ML-Made at SRA MD-Made at Depot	

- AO-Assembled by Unit/AVUM Level
 AF-Assembled by DS/AVIM Level
 AH-Assembled by GS level
 AL-Assembled by SRA
 AD-Assembled by Depot
- Items with these codes are not to be requested/requisitioned individually. The parts that make up the assembled item must be requisitioned or fabricated and assembled at the level of maintenance indicated by the source code. If the 3rd position of the SMR code authorizes you to replace the item, but the source code indicates the item is assembled at a higher level, order the item from the higher level of maintenance.
- XA Do not requisition an "XA" coded item. Order the next higher assembly. (Refer to NOTE below.)
- XB If an item is not available from salvage, order it using the CAGEC and P/N.
- XC Installation drawings, diagrams, instruction sheets, field service drawings, identified by manufacturer's P/N.
- XD Item is not stocked. Order an XD-coded item through normal supply channels using the CAGEC and P/N given, if no NSN is available.

NOTE

Cannibalization or controlled exchange, when authorized, may be used as a source of supply for items with the above source codes except for those source coded "XA" or those aircraft support items restricted by requirements of AR 750-1.

Maintenance Code. Maintenance codes tell you the level(s) of maintenance authorized to use and repair support items. The maintenance codes are entered in the third and fourth positions of the SMR code as follows:

Third Position. The maintenance code entered in the third position tells you the lowest maintenance level authorized to remove, replace, and use an item. The maintenance code entered in the third position will indicate authorization to the following levels of maintenance:

Maintenance Code

Application/Explanation

- C ---- Crew or operator maintenance done within unit/AVUM maintenance.
- O ---- Unit level/AVUM maintenance can remove, replace, and use the item.
- F ---- Direct support/AVIM maintenance can remove, replace, and use the item.
- H ---- General support maintenance can remove, replace, and use the item.
- L ---- Specialized repair activity can remove, replace, and use the item.
- D ---- Depot can remove, replace, and use the item.

Fourth Position. The maintenance code entered in the fourth position tells whether or not the item is to be repaired and identifies the lowest maintenance level with the capability to do complete repair (perform all authorized repair functions).

NOTE

Some limited repair may be done on the item at a lower level of maintenance, if authorized by the Maintenance Allocation Chart (MAC) and SMR codes.

**Maintenance
Code****Application/Explanation**

O ----	Unit/AVUM is the lowest level that can do complete repair of the item.
F ----	Direct support/AVIM is the lowest level that can do complete repair of the item.
H ----	General support is the lowest level that can do complete repair of the item.
L ----	Specialized repair activity is the lowest level that can do complete repair of the item.
D ----	Depot is the lowest level that can do complete repair of the item.
Z ----	Nonrepairable. No repair is authorized.
B ----	No repair is authorized. No parts or special tools are authorized for maintenance of a "B" coded item. However, the item may be reconditioned by adjusting, lubricating, etc., at the user level.

Recoverability Code. Recoverability codes are assigned to items to indicate the disposition action on unserviceable items. The recoverability code is entered in the fifth position of the SMR code as follows:

Code**Application/Explanation**

Z ----	Nonrepairable item. When unserviceable, condemn and dispose of the item at the level of maintenance shown in third position of SMR code.
O ----	Reparable item. When uneconomically repairable, condemn and dispose of the item at the unit level.
F ----	Reparable item. When uneconomically repairable, condemn and dispose of the item at the direct support level.
H ----	Reparable item. When uneconomically repairable, condemn and dispose of the item at the general support level.
D ----	Reparable item. When beyond lower level repair capability, return to depot. Condemnation and disposal of item not authorized below depot level.
L ----	Reparable item. Condemnation and disposal not authorized below Specialized Repair Activity (SRA).
A ----	Item requires special handling or condemnation procedures because of specific reasons (such as precious metal content, high dollar value, critical material, or hazardous material). Refer to appropriate manuals/directives for specific instructions.

NSN (Column (3)). The NSN for the item is listed in this column.

CAGEC (Column (4)). The Commercial and Government Entity Code (CAGEC) is a five-digit code which is used to identify the manufacturer, distributor, or Government agency/activity that supplies the item.

PART NUMBER (Column (5)). Indicates the primary number used by the manufacturer (individual, company, firm, corporation, or Government activity), which controls the design and characteristics of the item by means of its engineering drawings, specifications, standards, and inspection requirements to identify an item or range of items.

NOTE

When you use an NSN to requisition an item, the item you receive may have a different P/N from the number listed.

DESCRIPTION AND USABLE ON CODE (UOC) (Column (6)). This column includes the following information:

1. The federal item name and, when required, a minimum description to identify the item.
2. P/Ns of bulk materials are referenced in this column in the line entry to be manufactured or fabricated.
3. Hardness Critical Item (HCI). A support item that provides the equipment with special protection from electromagnetic pulse (EMP) damage during a nuclear attack.
4. The statement END OF FIGURE appears just below the last item description in column (6) for a given figure in both the repair parts list and special tools list work packages.

QTY (Column (7)). The QTY (quantity per figure) column indicates the quantity of the item used in the breakout shown on the illustration/figure, which is prepared for a functional group, subfunctional group, or an assembly. A "V" appearing in this column instead of quantity indicates that the quantity is variable and quantity may change from application to application.

EXPLANATION OF CROSS-REFERENCE INDEXES WORK PACKAGES FORMAT AND COLUMNS

1. National Stock Number (NSN) Index Work Package.

STOCK NUMBER Column. This column lists the NSN in National item identification number (NIIN) sequence. The NIIN consists of the last nine digits of the NSN.

NSN
 (e.g., 5305-01-574-1467)
 NIIN

When using this column to locate an item, ignore the first four digits of the NSN. However, the complete NSN should be used when ordering by stock number.

FIG. Column. This column lists the number of the figure where the item is identified/located. The figures are in numerical order in the repair parts list and special tools list work packages.

ITEM Column. The Item number identifies the item associated with the figure listed in the adjacent FIG. column. This item is also identified by the NSN listed on the same line.

2. Part Number (P/N) Index Work Package. P/Ns in this index are listed in ascending alphanumeric sequence (vertical arrangement of letter and number combinations which places the first letter or digit of each group in order A through Z, followed by the numbers 0 through 9, and each following letter or digit in like order).

PART NUMBER Column. Indicates the P/N assigned to the item.

FIG. Column. This column lists the number of the figure where the item is identified/located in the repair parts list and special tools list work packages.

ITEM Column. The item number is the number assigned to the item as it appears in the figure referenced in adjacent figure number column.

SPECIAL INFORMATION

UOC. The UOC appears in the lower left corner of the Description Column heading. Usable on codes are shown as "UOC: ..." in the Description Column (justified left) on the first line under the applicable item/nomenclature. Uncoded items are applicable to all models. Identification of the UOCs used in this RPSTL are:

<u>Code</u>	<u>Used On</u>
FHQ	M-80
FRH	M-85

Fabrication Instructions. Bulk materials required to manufacture items are listed in the bulk material functional group of this RPSTL. Part numbers for bulk material are also referenced in the Description Column of the line item entry for the item to be manufactured/fabricated. Detailed fabrication instructions for items source coded to be manufactured or fabricated are found in TB 10-4500-200-13.

Index Numbers. Items which have the word BULK in the figure column will have an index number shown in the item number column. This index number is a cross-reference between the NSN / P/N index work packages and the bulk material list in the repair parts list work package.

HOW TO LOCATE REPAIR PARTS

1. When NSNs or P/Ns Are Not Known.

First. Using the table of contents, determine the assembly group to which the item belongs. This is necessary since figures are prepared for assembly groups and subassembly groups, and lists are divided into the same groups.

Second. Find the figure covering the functional group or subfunctional group to which the item belongs.

Third. Identify the item on the figure and note the number(s).

Fourth. Look in the repair parts list work packages for the figure and item numbers. The NSNs and part numbers are on the same line as the associated item numbers.

2. When NSN Is Known.

First. If you have the NSN, look in the STOCK NUMBER column of the NSN index work package. The NSN is arranged in NIIN sequence. Note the figure and item number next to the NSN.

Second. Turn to the figure and locate the item number. Verify that the item is the one you are looking for.

3. When P/N Is Known.

First. If you have the P/N and not the NSN, look in the PART NUMBER column of the P/N index work package. Identify the figure and item number.

Second. Look up the item on the figure in the applicable repair parts list work package.

**UNIT MAINTENANCE
HEATER, WATER, LIQUID FUEL M-80 AND M-85
(NSN 4520-01-162-0385 (M-80) NSN 4520-01-237-3719 (M-85))
FUEL SUPPLY CONTROL COMPONENTS
REPAIR PARTS LIST**

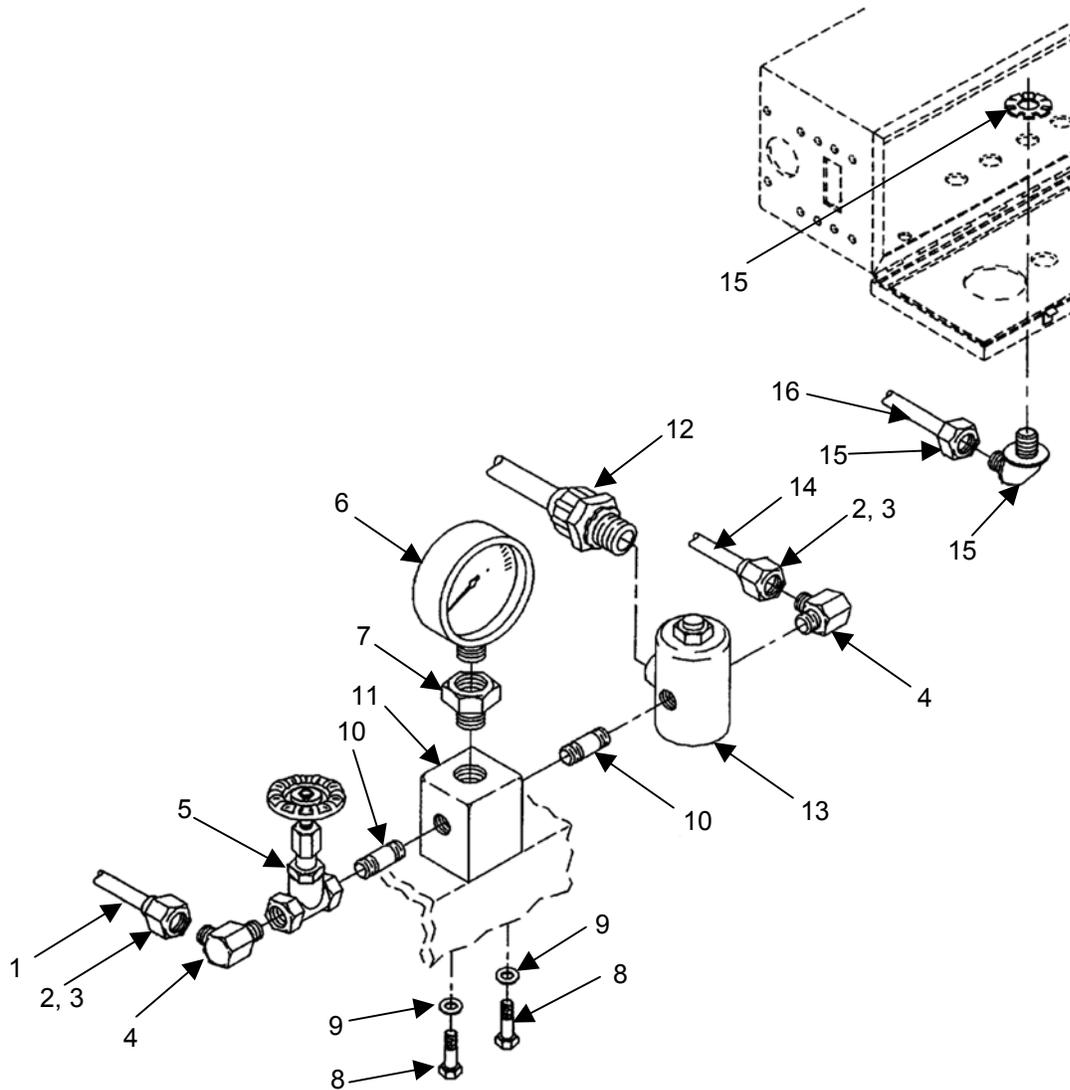

Figure 1. Fuel Supply Control Components

(1)	(2)	(3)	(4)	(5)	(6)	(7)
ITEM NO.	SMR CODE	NSN	CAGEC	PART NUMBER	DESCRIPTION AND USABLE ON CODE (UOC)	QTY
					GROUP 01 FUEL SUPPLY CONTROL COMPONENTS	
					FIG. 1 FUEL SUPPLY CONTROL COMPONENTS	
1	PAOZZ	4710-01-374-0238	81337	6-1-7494	TUBE ASSEMBLY, METAL, SOLENOID TO BURNER	1
2	XDOZZ		96906	MS51531-B5Z	NUT, TUBE COUPLING	4
3	PAOZZ	4730-00-433-3375	96906	MS20819-5	SLEEVE, FLARED, TUBE	4
4	XDOZZ		96906	MS51504-A5Z	ELBOW, PIPE TO TUBE	2
5	PAOZZ	4820-00-287-2784	00624	2024A-2-5S	VALVE, GLOBE 0.375 NPT OIL AND WATER.....	1
6	PAOZZ	6685-00-492-6230	61349	48365	GAGE, PRESSURE, DIAL INDICATING, 0-160 PSI, 0.250 NPT.....	1
7	PAOZZ	6685-00-851-6818	99752	25SE	DAMPENER, FLUID PRESSURE, MIL-D-2940, TYPE 2, CLASS 1, COMP A, ¼ IN NPT	1
8	PAOZZ	5305-00-068-0502	96906	MS90725-6	SCREW, CAP, HEXAGON HEAD	2
9	PAOZZ	5310-00-550-1130	96906	MS35333-40	WASHER, LOCK	2
10	PAOZZ	4730-01-921-3624	81346	A733S-6CFG	NIPPLE, PIPE.....	2
11	PAOZZ	4730-01-375-5528	90598	6-1-6257	TEE, PIPE	1
12	XDOZZ		81337	6-1-8110	CONNECTOR, STRAIGHT UL514, 1/8 IN LIQUID TIGHT	1
13	PAOZZ	4810-01-170-2433	81978	71215SN1KNO ONOC11P3	VALVE, SOLENOID.....	1
14	PAOZZ	4710-01-469-1237	2V507	89975K25	TUBE, METALLIC, SOLENOID TO PUMP	1
15	PAZZ	4320-01-376-0423	81337	6-1-6200-33	CONNECTOR, LIQUID TIGHT. UL 514, 90 DEG X 118 IN LG	1
16	XDOZZ		81337	6-1-6200-52	CONDUIT, METAL, FLEXIBLE.....	1
					END OF FIGURE	

UNIT MAINTENANCE
HEATER, WATER, LIQUID FUEL M-80 AND M-85
(NSN 4520-01-162-0385 (M-80) NSN 4520-01-237-3719 (M-85))
BURNER HEAD ASSEMBLY
REPAIR PARTS LIST

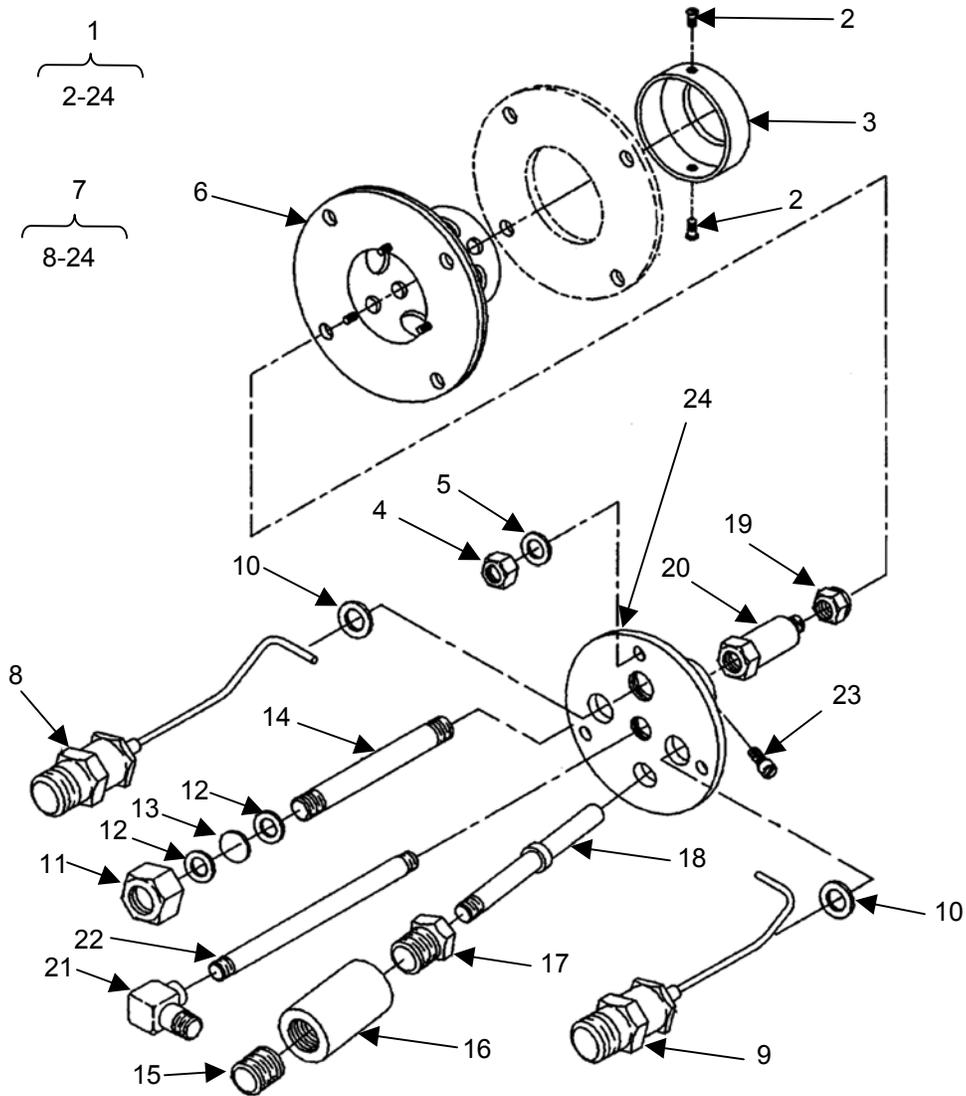

Figure 2. Burner Head Assembly
(Sheet 1 of 2, Model M-80)

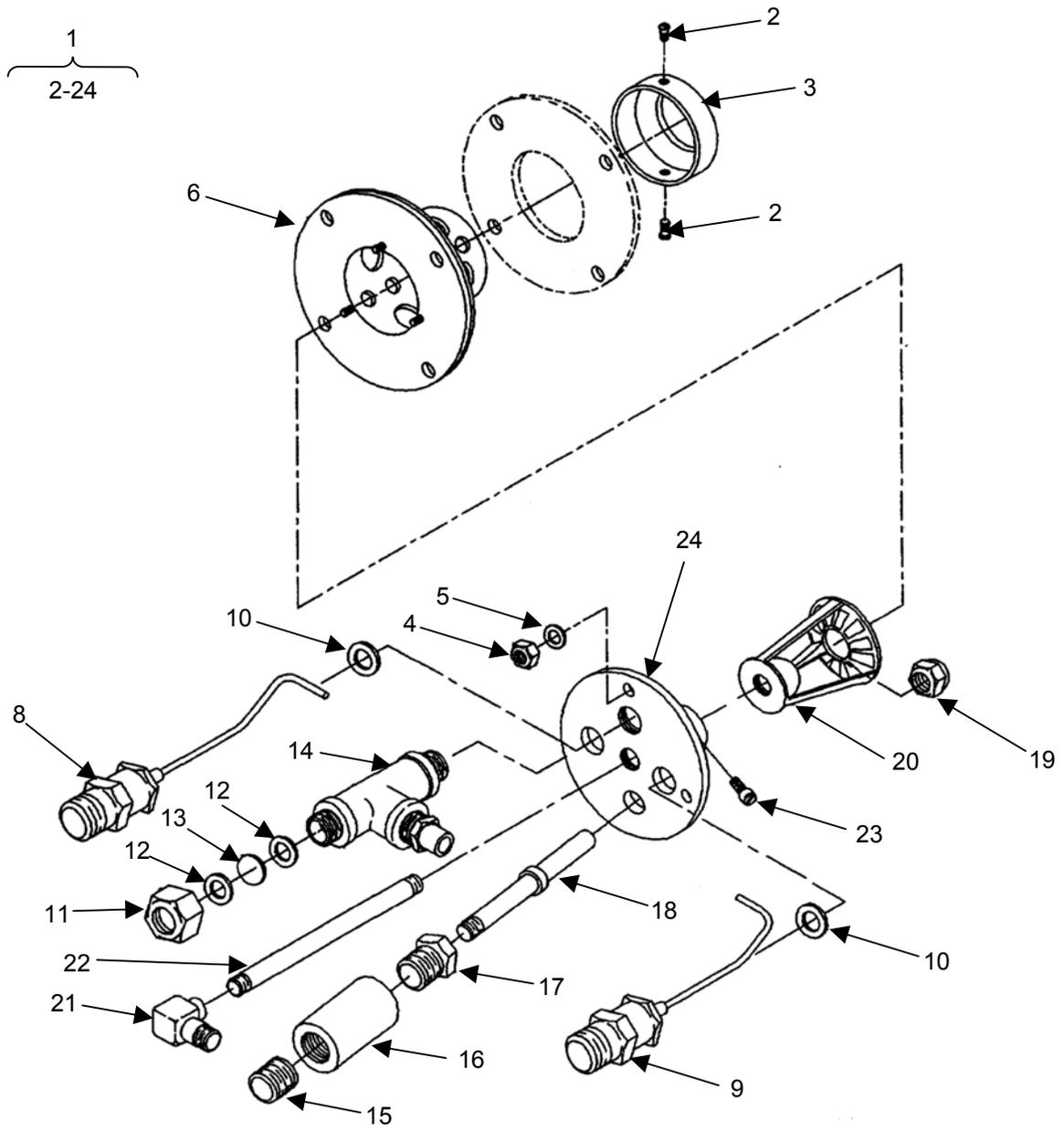

Figure 2. Burner Head Assembly
(Sheet 2 of 2, Model M-85)

(1)	(2)	(3)	(4)	(5)	(6)	(7)
ITEM NO.	SMR CODE	NSN	CAGEC	PART NUMBER	DESCRIPTION AND USABLE ON CODE (UOC)	QTY
					GROUP 02 BURNER HEAD ASSEMBLY	
					FIG. 2 BURNER HEAD ASSEMBLY	
1	XDOOO		81337	6-1-6236	HEAD ASSY, BURNER (MODEL M-80)....	1
1	XDOOO		81337	6-2-2454	HEAD ASSY, BURNER (MODEL M-85)....	1
2	PAOZZ	5305-00-948-4037	96906	MS35275-259	. SCREW MACHINE.....	2
3	PAOZZ	4720-01-375-2299	81337	6-1-6247	. NOSE, AIR	1
4	PAOZZ	5310-00-761-6882	96906	MS51967-2	. NUT, PLAIN, HEXAGON	3
5	PAOZZ	5310-00-550-1130	96906	MS35333-40	. WASHER, LOCK	3
6	XDOZZ		81337	6-1-6327	TUBE, BURNER.....	1
7	PAOOO	4530-01-180-2000	79466	168662	NOZZLE AND ELECTRODE ASSEMBLY	1
8	PAOZZ	4520-01-218-8575	81337	6-1-6240-1	IGNITER, SPARK, FUEL	1
9	PAOZZ	4520-01-227-1618	81337	6-1-6240-2	IGNITER, SPARK, FUEL.....	1
10	PAOZZ	5330-00-467-3553	0AFL4	M674	GASKET	2
11	PAOZZ	5340-01-468-5550	81337	6-1-6242	CAP-PLUG, PROTECTIVE, DUST AND MOISTURE, PEEP SIGHT	1
12	PAOZZ	5330-01-374-1501	90598	6-1-6244	GASKET, PEEP SIGHT.....	2
13	XDOZZ		81337	6-1-6243	GLASS, SAFETY, SINGLE.....	1
14	PAOZZ	4710-01-469-0587	81337	6-1-6241	TUBE, METALLIC, IGNITION, SIGHT UOC: FHQ	1
14	XDOZZ		81337	6-2-2461	TEE, ASSEMBLY UOC: FHR	1
15	PAOZZ	4730-00-196-1467	61465	102825	NIPPLE, PIPE.....	1
16	XDOZZ		96906	MS14304-2C08	COUPLING, PIPE.....	1
17	PAOZZ	4730-01-374-3639	81337	6-1-6238-14	BUSHING, PIPE WW-P-471, TYB, CLD FINISH C, SIZE A.....	1
18	PAOZZ	4710-01-374-3725	81337	6-1-6245	TUBE, METALLIC, SCANNER	1
19	PAOZZ	4530-01-375-2279	81337	6-1-8043	NOZZLE, OIL BURNER, PRESSURE, 60 DEGREES, 5 GPH	1
20	PAOZZ	4530-00-707-5965	81337	6-1-8042	ADAPTER, NOZZLE, OIL BURNER, PRESSURE ATOMIZING (FHQ)	1
20	XDOZZ		81337	6-2-2462	FLAMELOCK, MODIFIED UOC: FHR	1
21	XDOZZ		96906	MS51506A5Z	ELBOW, STREET	1
22	PAOZZ	4730-00-196-1538	96906	MS51953-17	NIPPLE, PIPE.....	1
23	PAOZZ	5305-00-723-9398	96906	MS51963-47	SETSCREW	4
24	PAOZZ	5977-01-469-8946	81337	6-1-6239	HOLDER, ELECTRODE.....	1
					END OF FIGURE	

UNIT MAINTENANCE
HEATER, WATER, LIQUID FUEL M-80 AND M-85
(NSN 4520-01-162-0385 (M-80) NSN 4520-01-237-3719 (M-85))
SMOKESTACK AND GUARD ASSEMBLY
REPAIR PARTS LIST

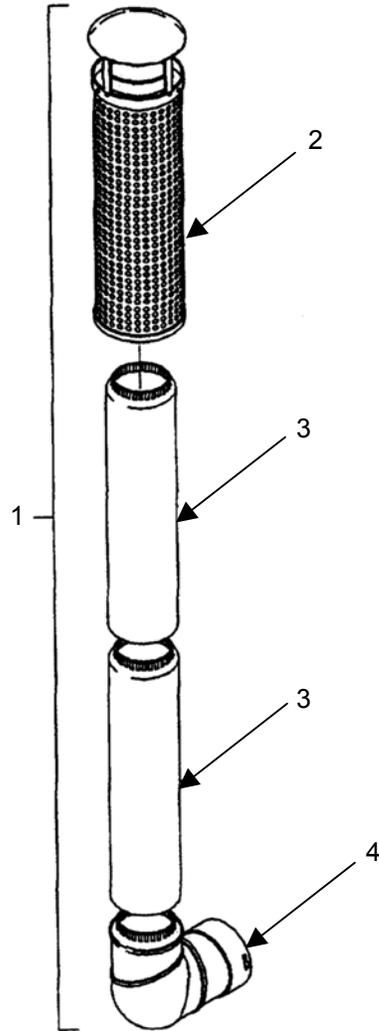

Figure 3. Smokestack and Guard Assembly

(1)	(2)	(3)	(4)	(5)	(6)	(7)
ITEM NO.	SMR CODE	NSN	CAGEC	PART NUMBER	DESCRIPTION AND USABLE ON CODE (UOC)	QTY
					GROUP 03 SMOKESTACK AND GUARD ASSEMBLY (MODEL M-80)	
1	XDOOO		81334	6-1-8259	FIG. 3 SMOKESTACK AND GUARD ASSEMBLY SMOKE STACK AND GUARD ASSEMBLY	
2	PAOZZ	4520-01-306-2057	81337	6-1-8264	UOC: FHQ.....	1
3	PAOZZ	4520-01-306-2111	81337	6-1-8263	CAP, FLUE UOC: FHQ.....	1
4	PAOZZ	4520-01-311-0900	81337	6-1-8260	PIPE, AIR CONDITIONING UOC: FHQ.....	2
					ELBOW, AIR CONDITIONING UOC: FHQ.....	1
					END OF FIGURE	

UNIT MAINTENANCE
HEATER, WATER, LIQUID FUEL M-80 AND M-85
(NSN 4520-01-162-0385 (M-80) NSN 4520-01-237-3719 (M-85))
IGNITION TRANSFORMER AND CABLE ASSEMBLIES
REPAIR PARTS LIST

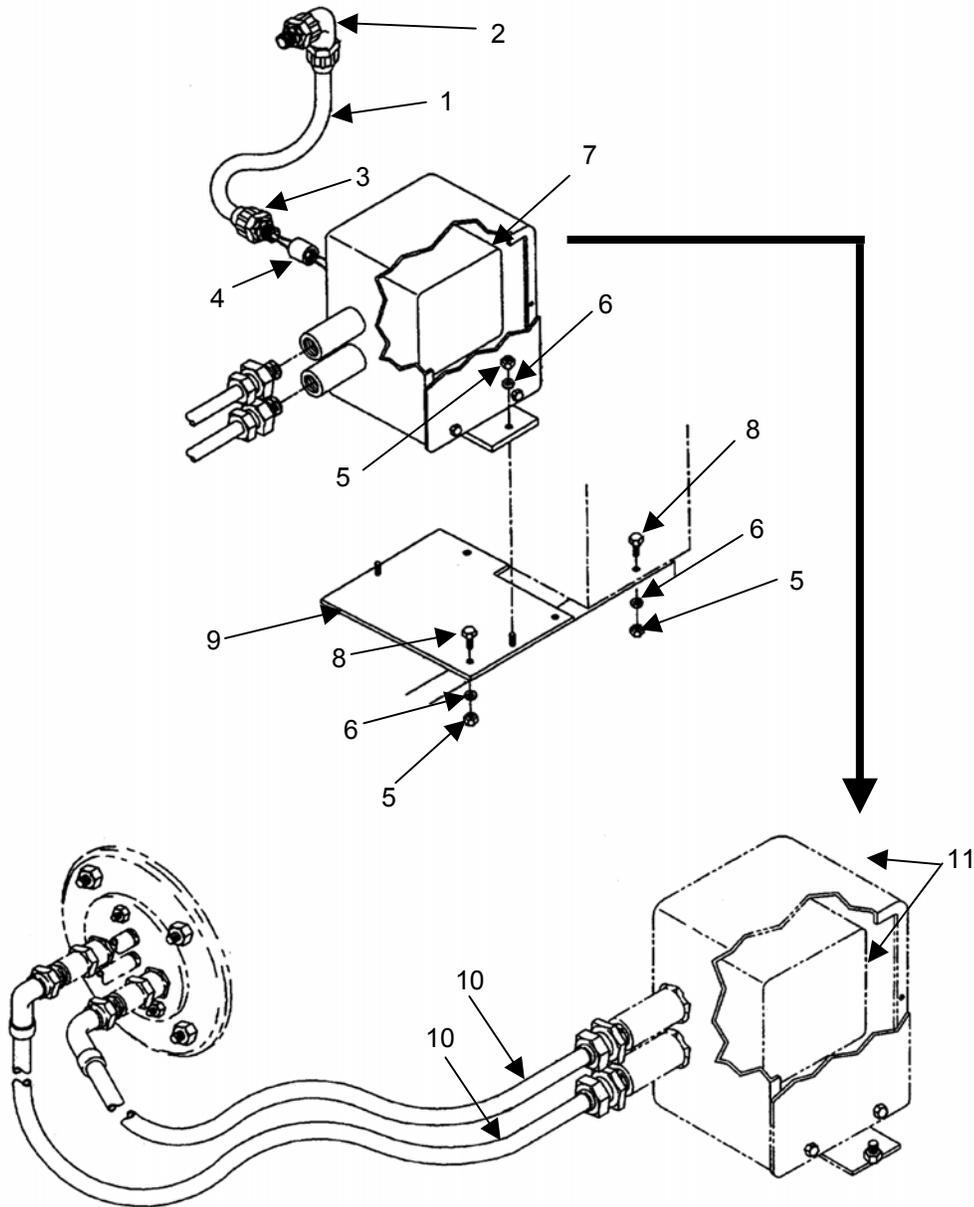

Figure 4. Ignition Transformer and Cable Assemblies

(1) ITEM NO.	(2) SMR CODE	(3) NSN	(4) CAGEC	(5) PART NUMBER	(6) DESCRIPTION AND USABLE ON CODE (UOC)	(7) QTY
					GROUP 04 IGNITION TRANSFORMER AND CABLE ASSEMBLIES	
					FIG. 4 IGNITION TRANSFORMER AND CABLE ASSEMBLIES	
1	XDOZZ		81349	MIL-C-13909C TYPE 1 GRADE B	CONDUIT, FLEXIBLE.....	1
2	PAOZZ	5975-00-995-5260	56501	5351	BOX, CONNECTOR, ELECTRICAL	1
3	PAOZZ	5975-00-707-6229	59730	5331	BOX, CONNECTOR, ELECTRICAL	1
4	PAOZZ	4730-01-374-3676	81337	6-1-9336	COUPLING, PIPE.....	1
5	PAOZZ	5310-00-997-1888	96906	MS35649-2252	NUT, PLAIN, HEXAGON	9
6	PAOZZ	5310-00-550-1130	96906	MS35333-40	WASHER, LOCK	9
7	PAOZZ	5950-00-454-5463	84768	T1-10	TRANSFORMER, POWER 120 VOLTS, 60 HZ PRIMARY	1
8	PAOZZ	5305-00-068-0502	96906	MS90725-6	SCREW, CAP, HEXAGON HEAD	7
9	PAOZZ	5340-01-468-6667	81337	6-1-6258	PLATE, MOUNTING.....	1
10	PAOZZ	6150-01-219-8696	81337	6-1-6263	CABLE ASSEMBLY, SPECIAL PURPOSE, ELECTRICAL	2
11	PAOFF	6150-01-509-9934	81337	1-6-2623	MODIFICATION KIT, ELECTRIC, POWER CONVERSION OF 208V TRANSFORMER TO 110V, INSTRUCTIONS, WIRING, TRANSFORMER.....	1
END OF FIGURE						

UNIT MAINTENANCE
HEATER, WATER, LIQUID FUEL M-80 AND M-85
(NSN 4520-01-162-0385 (M-80) NSN 4520-01-237-3719 (M-85))
ELECTRICAL COMPONENTS
REPAIR PARTS LIST

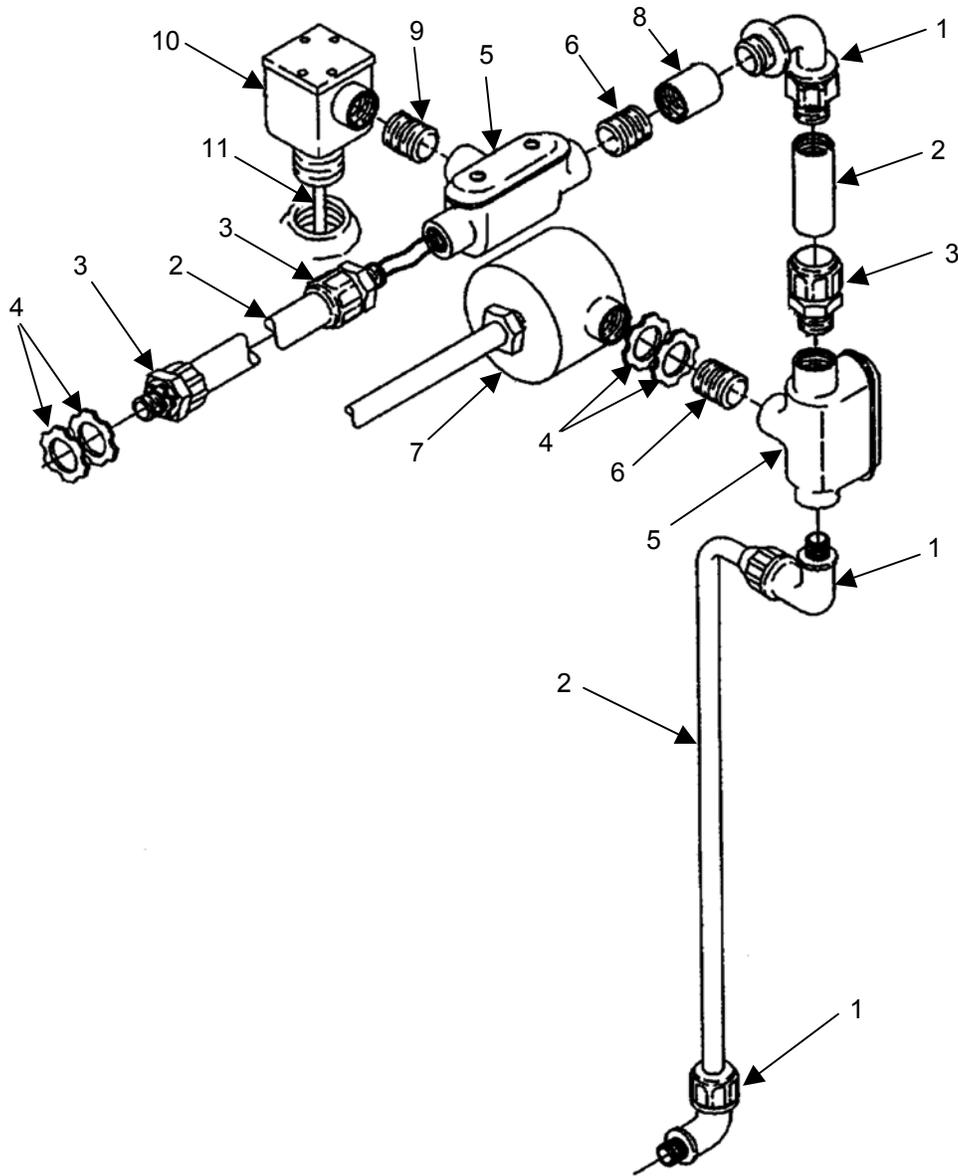

Figure 5. Electrical Components

(1)	(2)	(3)	(4)	(5)	(6)	(7)
ITEM NO.	SMR CODE	NSN	CAGEC	PART NUMBER	DESCRIPTION AND USABLE ON CODE (UOC)	QTY
					GROUP 0401 ELECTRICAL COMPONENTS	
1	XDOZZ		81337	6-1-6200-29	FIG. 5 ELECTRICAL COMPONENTS ELBOW, CONNECTOR, W-F-408, TY1, CL 2, KINK M, STYLE 2, 90 x 0.50.....	3
2	XDOZZ		81337	6-1-6200-28	CONDUIT, METAL, RIGID THIN WALL, 0.50 STEEL	3
3	XDOZZ		81337	6-1-6200-30	CONNECTOR, BOX, ELECTRICAL, W-F-408, TY1, CL2, KINDL, STYLE2, 0.50 ...	3
4	XDOZZ		81337	6-1-6200-31	LOCKNUT, ELECTRICAL, W-F-408, TY3, CL1, KIND P, 1/2 IN.....	4
5	XDOZZ		81337	6-1-6200-32	TEE, ELECTRICAL, W-C-586, TY1, DESIGN 1, STYLE T, 0.50 X 0.50 x 0.50 ..	2
6	XDOZZ		96906	MS51953-75	NIPPLE, PIPE.....	2
7	PAOZZ	6685-01-357-7533	OKDP7	23-021110-000	CONTROL, TEMPERATURE INDICATING.....	1
8	XDOZZ		81337	6-1-8094	COUPLING.....	1
9	XDOZZ		81337	6-1-8122	NIPPLE, CHASE 0.50.....	1
10	PAOZZ	5977-01-161-6680	81337	6-1-8102	HOLDER, ELECTRODE.....	1
11	PAOZZ	5977-01-161-8056	79198	3R1B0	ELECTRODE.....	1
					END OF FIGURE	

UNIT MAINTENANCE
 HEATER, WATER, LIQUID FUEL M-80 AND M-85
 (NSN 4520-01-162-0385 (M-80) NSN 4520-01-237-3719 (M-85))
 BLOWER ASSEMBLY
 REPAIR PARTS LIST

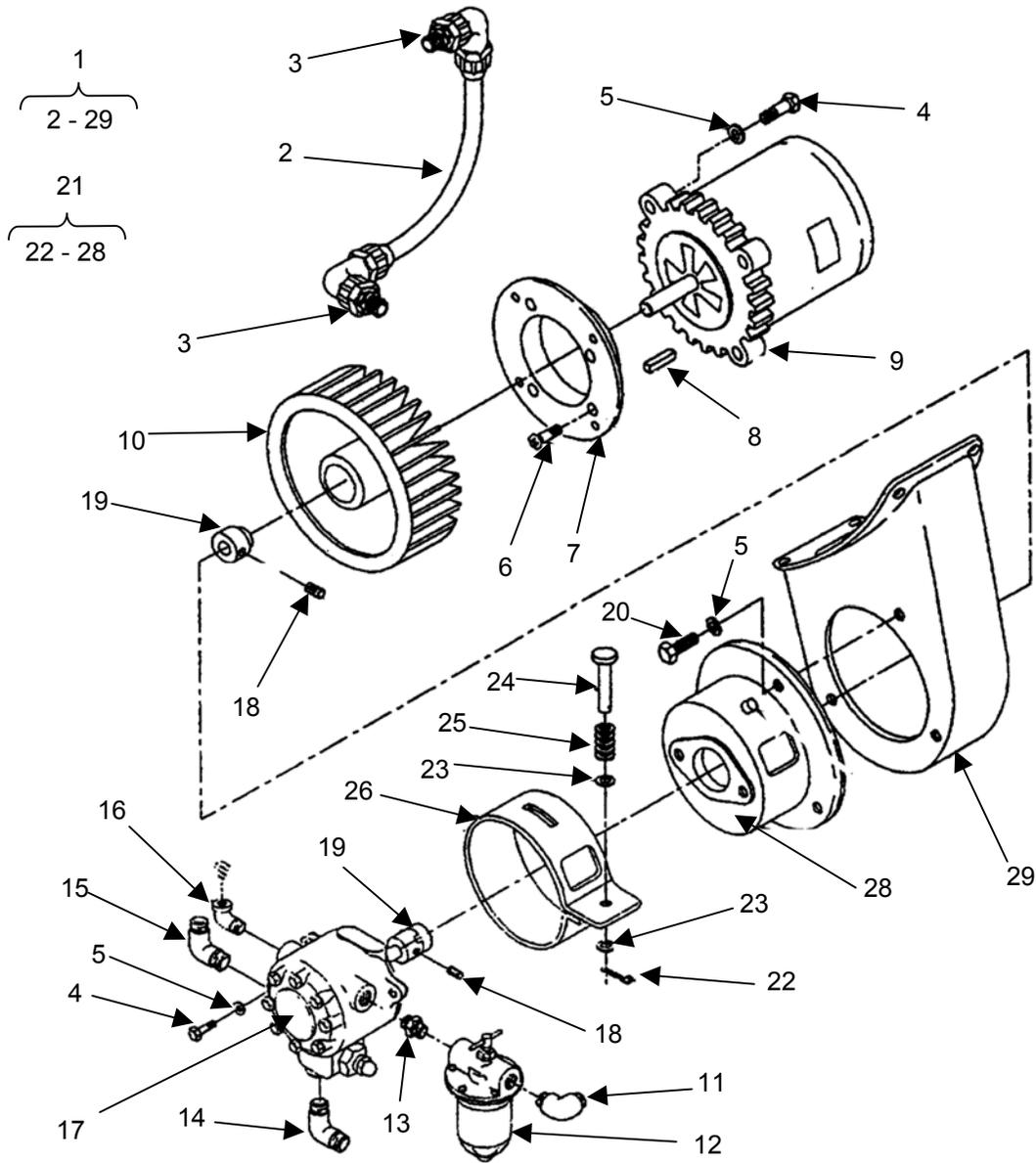

Figure 6. Blower Assembly

(1)	(2)	(3)	(4)	(5)	(6)	(7)
ITEM NO.	SMR CODE	NSN	CAGEC	PART NUMBER	DESCRIPTION AND USABLE ON CODE (UOC)	QTY
GROUP 05 BLOWER ASSEMBLY						
FIG. 6 BLOWER ASSEMBLY						
1	PAOFF	3510-01-440-8911	81337	6-1-6225-101	BLOWER ASSEMBLY.....	1
2	XDOZZ		81337	6-1-6225-14	. CONDUIT, FLEXIBLE.....	1
3	PAFZZ	5975-00-707-6229	59730	5331	. BOX CONNECTOR, ELECTRICAL.....	2
4	PAFZZ	5975-00-269-3211	25567	B-0604	. SCREW, CAP, HEXAGON HEAD.....	6
5	PAFZZ	5310-00-595-7237	96906	MS35333-42	. WASHER, LOCK.....	9
6	PAFZZ	5303-00-958-5260	96906	MS35190-321	. SCREW, MACHINE.....	4
7	PAOZZ	5340-01-468-5416	81337	6-1-6227	. MOUNTING PLATE.....	1
8	PAFZZ	5315-01-468-6827	81337	6-1-6234	. KEY, MACHINE.....	1
9	PAFZZ	6105-01-211-6845	03510	5K33FN311U	. MOTOR, ELECTRIC.....	1
10	PAFZZ	4140-01-375-2270	95933	631-200S	. IMPELLER, FAN, CENTRIFUGAL.....	1
11	PAOZZ	4730-00-287-1024	96906	MS20822-8D	ELBOW, PIPE TO TUBE UOC: FHQ.....	1
12	PAOOO	4330-01-356-0850	81337	6-1-8040	. FILTER, FLUID SEE WP 0046 00 FOR BREAKDOWN.....	1
13	XDOZZ		81337	6-1-8097	. REDUCER, PIPE UOC: FHQ.....	1
14	XDOZZ		96906	MS51504-B8-4Z	. ELBOW, PIPE TO TUBE.....	1
15	PAOZZ	4730-00-278-3678	96906	MS20822-5D	. ELBOW, PIPE TO TUBE.....	1
16	PAOZZ	4730-01-374-3633	81337	6-1-8095	. ELBOW, PIPE.....	1
17	PAFFF	4320-00-432-1691	1Y370	H3BA100	. PUMP, ROTARY SEE WP 0047 00 FOR BREAKDOWN.....	1
17	PAFFF	4320-00-707-4851	1Y370	J3BA-178P	. PUMP, ROTARY SEE WP 0047 00 FOR BREAKDOWN.....	1
18	PAFZZ	5305-00-723-9386	96906	MS51963-64	. SETSCREW.....	2
19	PAOZZ	3010-01-374-3657	75665	68514444829	COUPLING SHAFT, FLEXIBLE.....	2
20	XDFZZ		96906	MS90725-61	. SCREW, CAP, HEX HEAD.....	3
21	PAFFF	5670-01-441-4500	81337	6-1-6228	. VENTILATOR, AIR CIRCULATING, BLOWER ASSEMBLY.....	1
22	PAFZZ	5315-00-619-7158	96906	MS9245-25	. . PIN, COTTER.....	1
23	XDFZZ		96906	MS15795-910	. . WASHER, FLAT.....	2
24	XDFZZ		81337	6-1-6232	. . RIVET, BLIND.....	3
25	PAFZZ	5360-01-468-8792	81337	6-1-6233	. . SPRING, HELICAL, COMP.....	1
26	PAFZZ	5340-01-468-5423	81337	6-1-6230	. . LOOP, CLAMP.....	1
27	PAFZZ	5315-01-468-6808	81337	6-1-6231	. . PIN, STRAIGHT, HEADLESS.....	1
28	PAFZZ	5340-01-468-5430	81337	6-1-6229	. . MOUNTING BRACKET.....	1
29	PAFZZ	4140-01-468-6724	81337	6-1-6226	. HOUSING, CENTRIFUGAL.....	1
END OF FIGURE						

UNIT MAINTENANCE
HEATER, WATER, LIQUID FUEL M-80 AND M-85
(NSN 4520-01-162-0385 (M-80) NSN 4520-01-237-3719 (M-85))
FUEL FILTER ASSEMBLY
REPAIR PARTS LIST

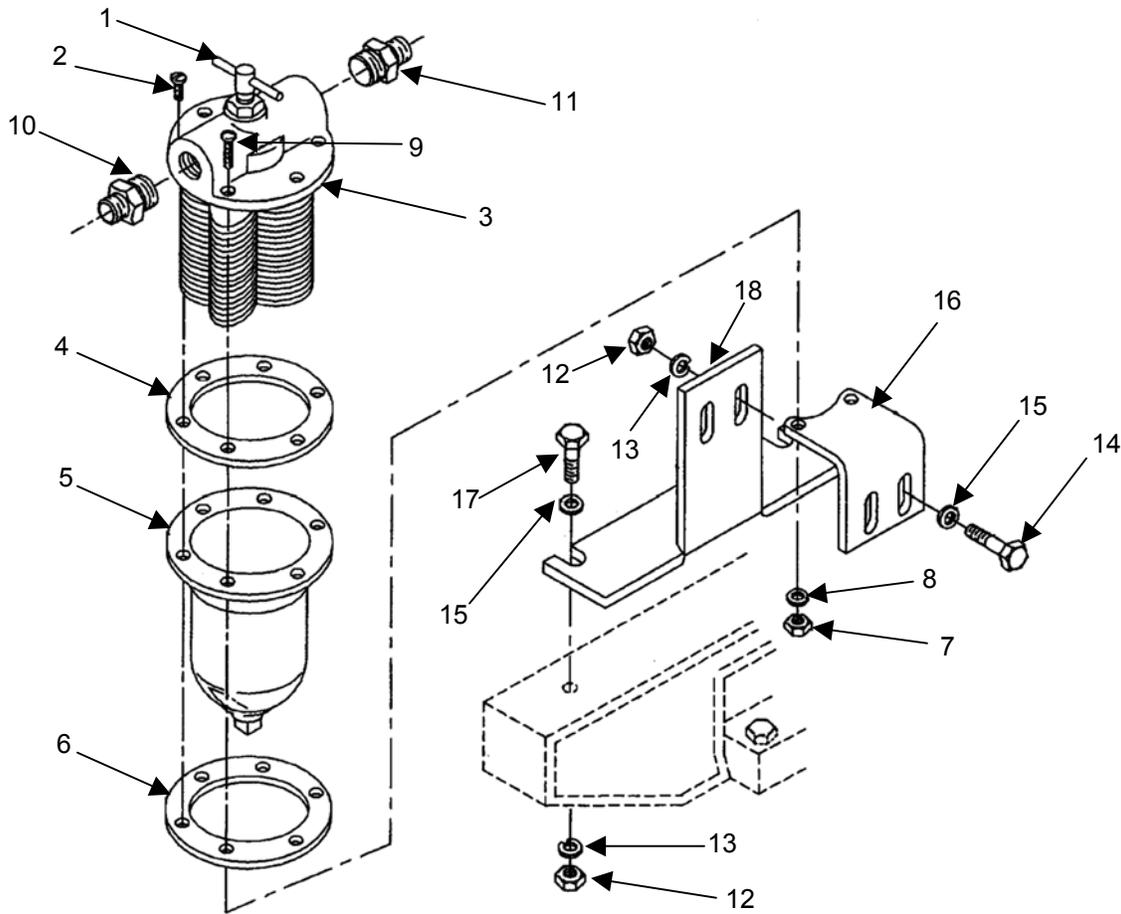

Figure 7. Fuel Filter Assembly

(1)	(2)	(3)	(4)	(5)	(6)	(7)
ITEM NO.	SMR CODE	NSN	CAGEC	PART NUMBER	DESCRIPTION AND USABLE ON CODE (UOC)	QTY
					GROUP 0502 FUEL FILTER ASSEMBLY	
1	PAOZZ	4330-01-278-3614	15472	98801-01	FIG. 7 FUEL FILTER ASSEMBLY . . PARTS KIT, FLUID PRESSURE FILTER; (PACKING, FOLLOWER, NUT, PIN, HANDLE).....	1
2	PAOZZ	5305-00-984-6212	96906	MS35206-265	. . SCREW, MACHINE.....	4
3	PAOOO	4331-01-356-0850	15472	12706-02-20-0035	. . FILTER, FLUID.....	1
4	PAOZZ	5330-00-360-5303	15472	32845-31	. . GASKET.....	1
5	PAOZZ	2910-01-466-5246	15472	22342-00	. . FILTER BODY, FLUID.....	1
6	XDOZZ		15472	28329-00	. . RING, REINFORCING.....	1
7	XDOZZ		96906	MS35649-202	NUT, PLAIN, HEXAGON.....	2
8	PAOZZ	5310-00-576-5752	96906	MS35333-39	WASHER, LOCK.....	2
9	PAOZZ	5305-00-240-6668	96906	MS51849-78	SCREW, MACHINE.....	2
10	XDOZZ		96906	MS51500-B8S	ADAPTER, STRAIGHT, PIPE TO TUBE...	1
11	PAOZZ	4730-01-321-9921	01276	2021-6-4C	ADAPTER, STRAIGHT, PIPE.....	1
12	PAOZZ	5310-00-997-1888	96906	MS35649-2252	NUT, PLAIN, HEXAGON.....	4
13	PAOZZ	5310-00-550-1130	96906	MS35333-40	WASHER, LOCK.....	4
14	PAOZZ	5305-00-225-3843	80204	B1821BH025C100N	SCREW, CAP, HEXAGON HEAD.....	2
15	PAOZZ	5310-00-809-4058	96906	MS27813-10	WASHER, FLAT.....	4
16	PAOZZ	5340-01-468-7710	81337	6-1-6256	BRACKET, MOUNTING.....	1
17	PAOZZ	5305-00-068-0502	96906	MS90725-6	SCREW, CAP, HEXAGON.....	2
18	XDOZZ		81337	6-1-6225	BRACKET, FILTER, MOUNTING.....	1
					END OF FIGURE	

UNIT MAINTENANCE
HEATER, WATER, LIQUID FUEL M-80
(NSN 4520-01-162-0385 (M-80))
FUEL PUMP
REPAIR PARTS LIST

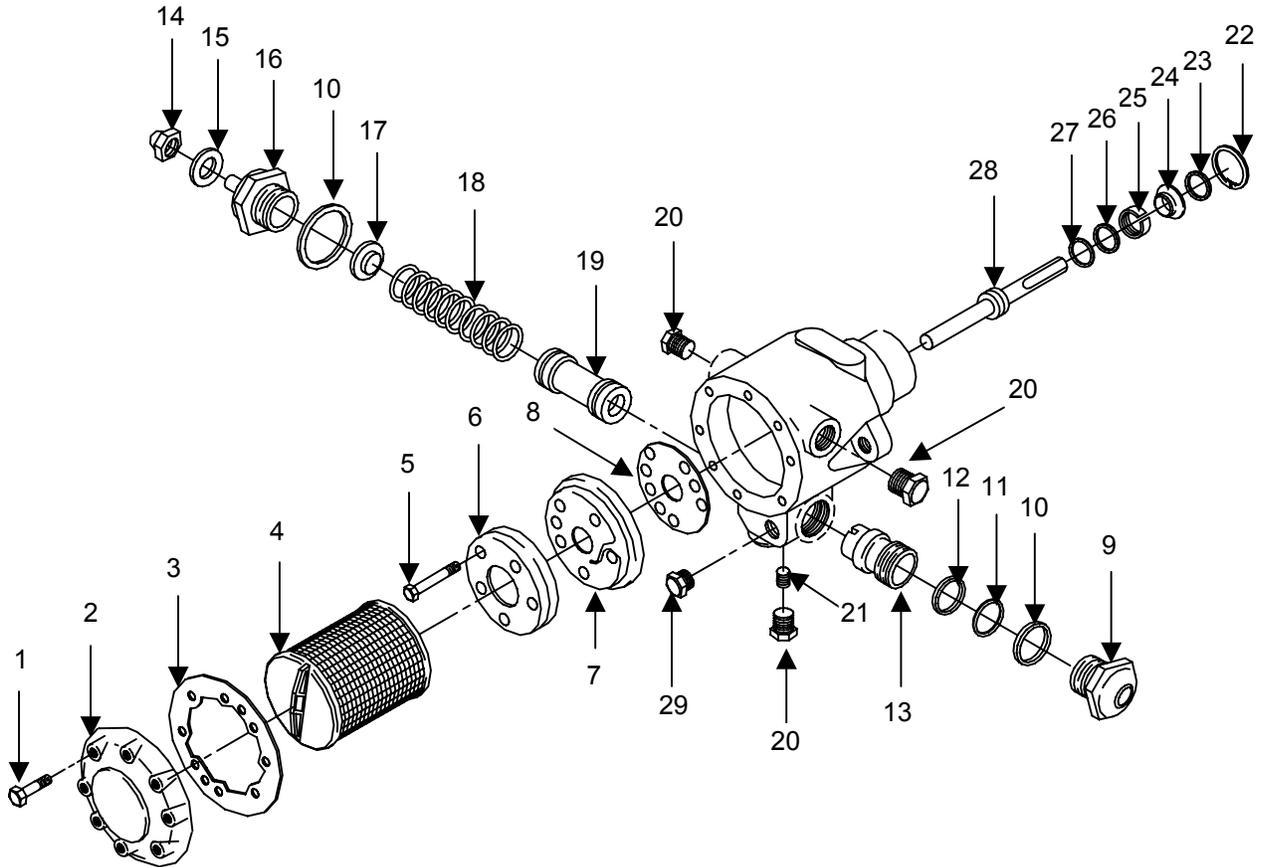

Figure 8. Fuel Pump (Model M-80)

(1)	(2)	(3)	(4)	(5)	(6)	(7)
ITEM NO.	SMR CODE	NSN	CAGEC	PART NUMBER	DESCRIPTION AND USABLE ON CODE (UOC)	QTY
					GROUP 0503 FUEL PUMP	
					FIG. 8 FUEL PUMP, M-80	
1	XDFZZ		1Y370	111401	.. SCREW, COVER UOC: FHQ	8
2	XDFZZ		1Y370	131596	.. COVER UOC: FHQ	1
3	PAFZZ	5330-00-375-1690	1Y370	110441	.. GASKET UOC: FHQ	1
4	XDFZZ		1Y370	131622	.. STRAINER ELEMENT UOC: FHQ	1
5	XDFZZ		1Y370	104671	.. SCREW, GEARSET UOC: FHQ	5
6	XDFZZ		1Y370	124027	.. PLATE ASSEMBLY, END UOC: FHQ	1
7	XDFZZ		1Y370	117531	.. HOUSING, PORT UOC: FHQ	1
8	PAFZZ	5330-00-718-6547	1Y370	113331	.. GASKET UOC: FHQ	1
9	XDFZZ		1Y370	114227	.. PLUG ASSEMBLY UOC: FHQ	1
10	PAFZZ	5330-00-527-7560	1Y370	100901	.. GASKET UOC: FHQ	2
11	PAFZZ	4520-00-976-2253	1Y370	121732	.. SLEEVE, RETAINER UOC: FHQ	1
12	PAFZZ	5310-00-037-4935	1Y370	25815	.. WASHER, FLAT UOC: FHQ	1
13	XDFZZ		1Y370	121222	.. CYLINDER, SLEEVE UOC: FHQ	1
14	PAFZZ	5310-00-472-6204	1Y370	100241	.. NUT, PLAIN, CAP UOC: FHQ	1
15	PAFZZ	5330-00-472-6189	1Y370	100371	.. GASKET UOC: FHQ	1
16	XDFZZ		1Y370	103379	.. PLUG, ASSY, END UOC: FHQ	1
17	XDFZZ		1Y370	100931	.. SEAT, SPRING UOC: FHQ	1
18	XDFZZ		1Y370	728335	.. SPRING, HELICAL UOC: FHQ	1
19	XBFZZ		1Y370	116106	.. PISTON ASSEMBLY UOC: FHQ	1
20	XDFZZ		1Y370	3759231	.. VALVE, BLEEDER PUMP UOC: FHQ	3
21	XDFZZ		1Y370	24800	.. PLUG, BYPASS UOC: FHQ	1
22	XDFZZ		1Y370	51017	.. RING, RETAINING UOC: FHQ	1
23	PBFZZ	5330-00-953-4407	1Y370	125132	.. PACKING, PREFORMED UOC: FHQ	1
24	PAFZZ	5330-00-482-7051	1Y370	115462	.. SEAL, LAUNDRY UNIT UOC: FHQ	1
25	XDFZZ		1Y370	129792	.. SEAL UOC: FHQ	1
26	XDFZZ		1Y370	129521	.. WASHER UOC: FHQ	1

(1)	(2)	(3)	(4)	(5)	(6)	(7)
ITEM NO.	SMR CODE	NSN	CAGEC	PART NUMBER	DESCRIPTION AND USABLE ON CODE (UOC)	QTY
27	PAFZZ	5330-00-218-0390	1Y370	125122	.. O-RING UOC: FHQ.....	1
28	XAFZZ		1Y370	117667	.. SHAFT ASSEMBLY UOC: FHQ.....	1
END OF FIGURE						

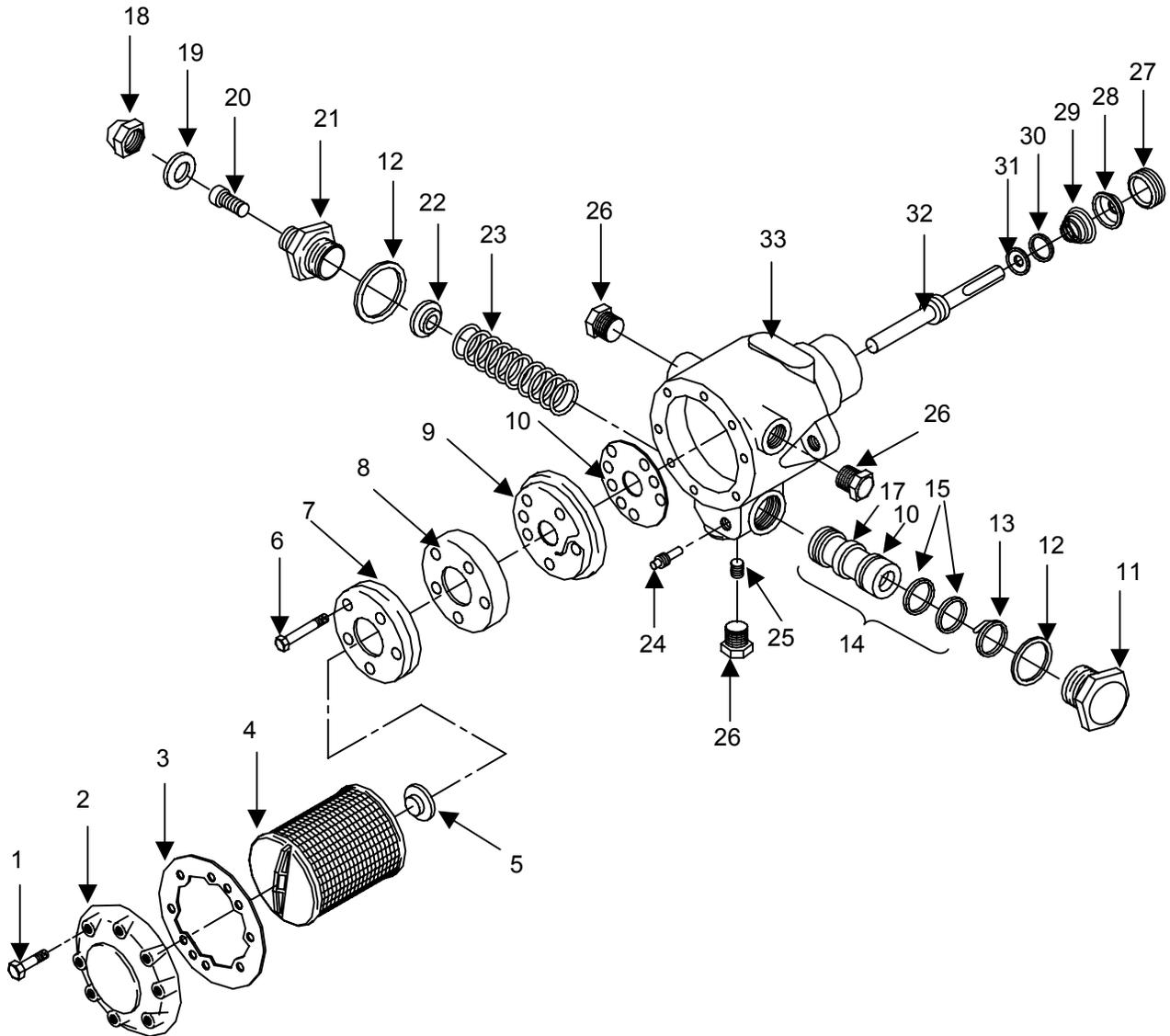

Figure 9. Fuel Pump (Model M-85)

(1)	(2)	(3)	(4)	(5)	(6)	(7)
ITEM NO.	SMR CODE	NSN	CAGEC	PART NUMBER	DESCRIPTION AND USABLE ON CODE (UOC)	QTY
					GROUP 0503 FUEL PUMP	
1	XDFZZ		1Y370	111401	FIG. 9 FUEL PUMP M-85 SCREW, HEX HEAD UOC: FHR	8
2	XDFZZ		1Y370	120353	COVER, ACS UOC: FHR	1
3	PCFZZ	5330-00-375-1690	1Y370	110441	GASKET UOC: FHR	1
4	XDFZZ		1Y370	131129	FILTER ELEMENT, FLUID UOC: FHR	1
5	PAFZZ	4330-00-461-3964	1Y370	122822	DIAPHRAGM, FUEL PUMP UOC: FHR	1
6	XDFZZ		1Y370	134122	SCREW, HEX HEAD UOC: FHR	5
7	XDFZZ		1Y370	134137	COVER, HYDRAULIC, PUMP UOC: FHR	1
8	XDFZZ		1Y370	128527	SPACER, PLATE UOC: FHR	1
9	XAFZZ		1Y370	128283	HOUSING, LIQUID PUMP UOC: FHR	1
10	XDFZZ	5330-00-718-6547	1Y370	113331	GASKET UOC: FHR	1
11	PAFZZ		1Y370	109777	PLUG UOC: FHR	1
12	PAFZZ	5330-00-527-7560	1Y370	100901	GASKET UOC: FHR	2
13	PAFZZ	4520-00-976-2253	1Y370	121732	SLEEVE, RETAINER UOC: FHR	1
14	PAFZZ	4320-01-006-4734	1Y370	991096	PARTS KIT, ROTARY PUMP UOC: FHR	1
15	PAFZZ	5310-00-037-4935	1Y370	25815	WASHER, FLAT UOC: FHR	2
16	XAFZZ		1Y370	128403	PISTON UOC: FHR	1
17	XAFZZ		1Y370	128433	CYLINDER, SLEEVE UOC: FHR	1
18	XAFZZ	5310-00-472-6204	1Y370	100241	NUT, PLAIN, CAP UOC: FHR	1
19	PAFZZ	5330-00-472-6189	1Y370	100371	. . GASKET UOC: FHR	1
20	XDFZZ		1Y370	101001	. . SCREW UOC: FHR	1
21	XDFZZ		1Y370	103379	. . PLUG ASSY, END UOC: FHR	1
22	XDFZZ		1Y370	100931	. . SEAT, HELICAL COMPRE UOC: FHR	1
23	XDFZZ		1Y370	101641	. . SPRING, HELICAL UOC: FHR	1
24	XDFZZ		1Y370	3759231	. . VALVE, BLDR PMP UOC: FHR	1
25	XDFZZ		1Y370	24800	. . PLUG, MACH THREAD UOC: FHR	1
26	PAFZZ	4730-00-251-1010	1Y370	3729241	. . PLUG, PIPE UOC: FHR	3
27	PAFZZ	4730-00-028-3862	1Y370	100031	. . PACKING NUT UOC: FHR	1

(1)	(2)	(3)	(4)	(5)	(6)	(7)
ITEM NO.	SMR CODE	NSN	CAGEC	PART NUMBER	DESCRIPTION AND USABLE ON CODE (UOC)	QTY
28	PAFZZ	5310-00-374-6103	1Y370	100291	. . WASHER, SHOULDERED AND RECESSED UOC: FHR.....	1
29	PAFZZ	5360-00-472-6224	1Y370	100301	. SPRING, HELICAL, COMPRESSION UOC: FHR.....	1
30	PAFZZ	5330-00-374-6104	1Y370	100319	. . PACKING, PREFORMED UOC: FHR.....	1
31	XDFZZ		1Y370	101861	. . SHIM UOC: FHR.....	1
32	XDFZZ		1Y370	109026	. . SHAFT ASSEMBLY UOC: FHR.....	1
33	XDFZZ		1Y370	170070	. . HOUSING, LIQUID PUMP UOC: FHR.....	1
END OF FIGURE						

UNIT MAINTENANCE
HEATER, WATER, LIQUID FUEL M-80 AND M-85
(NSN 4520-01-162-0385 (M-80) NSN 4520-01-237-3719 (M-85))
WATER VESSEL AND SKID ASSEMBLY
REPAIR PARTS LIST

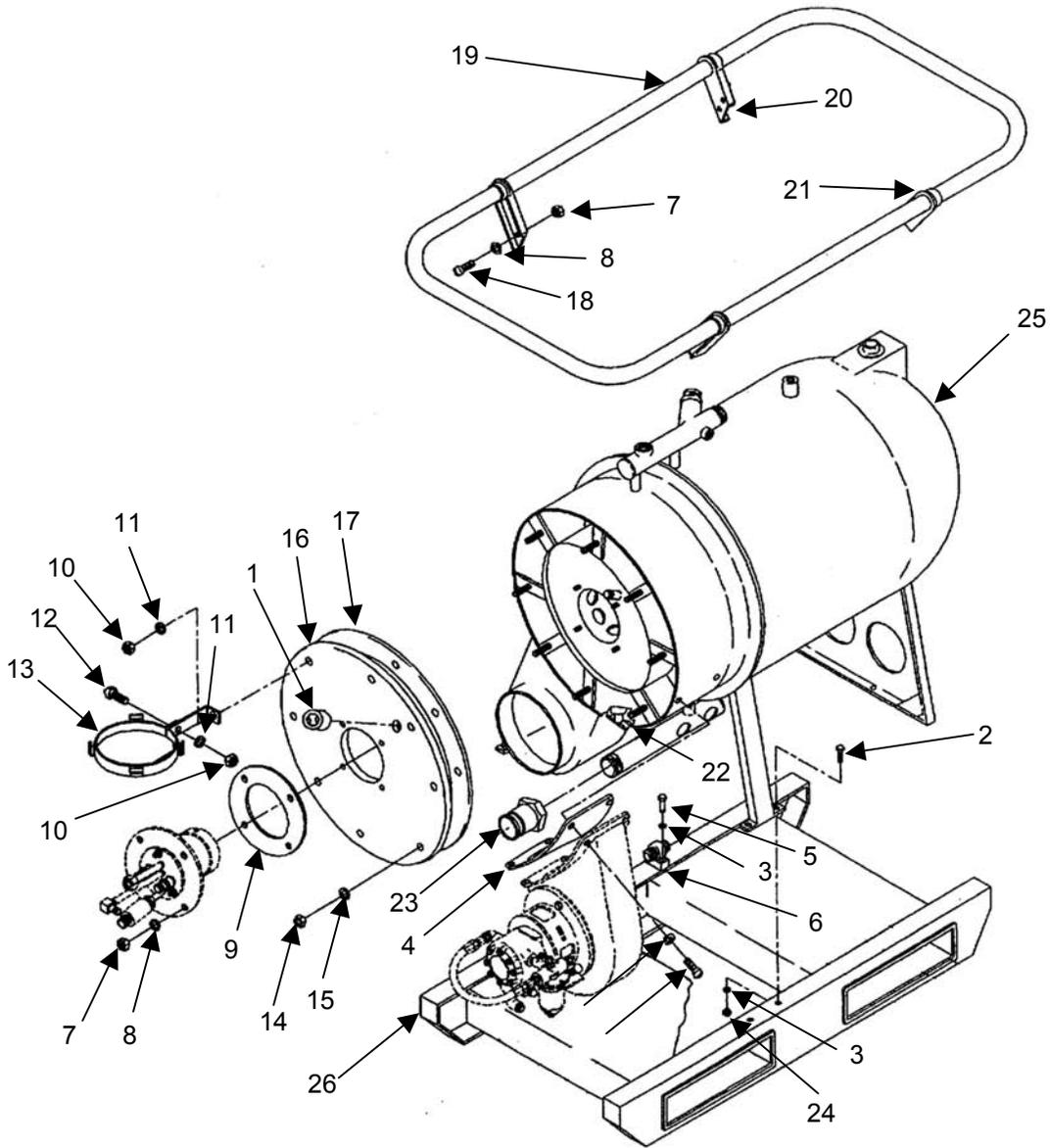

Figure 10. Water Vessel and Skid Assembly

(1)	(2)	(3)	(4)	(5)	(6)	(7)
ITEM NO.	SMR CODE	NSN	CAGEC	PART NUMBER	DESCRIPTION AND USABLE ON CODE (UOC)	QTY
					GROUP 06 WATER VESSEL AND SKID ASSEMBLY	
					FIG. 10 WATER VESSEL AND SKID ASSEMBLY	
1	PAOZZ	6680-01-306-2079	81337	6-1-6248	INDICATOR, SIGHT, LIQUID	1
2	XDOZZ		96906	M590725-60	SCREW, CAP, HEXAGON HEAD	12
3	PAOZZ	5310-00-595-7237	96906	MS35333-42	WASHER, LOCK	14
4	PAOZZ	5330-01-373-9758	90598	6-1-6235	GASKET	1
5	XDOZZ		96906	MS90725-8	SCREW, CAP, HEXAGON HEAD	2
6	PAOZZ	4730-01-375-2229	81337	6-1-6262	UNION, TUBE	1
7	PAOZZ	5310-00-997-1888	96906	MS35649-2252	NUT, PLAIN, HEXAGON	12
8	PAOZZ	5310-00-550-1130	96906	MS35333-40	WASHER, LOCK	8
9	PAOZZ	5330-01-374-3662	81337	6-1-6260	GASKET	1
10	PAOZZ	5310-00-761-6882	96906	MS51967-2	NUT, PLAIN, HEXAGON UOC: FHQ	2
11	PAOZZ	5310-00-582-5965	96906	MS35338-44	WASHER, LOCK UOC: FHQ	2
12	PAOZZ	5305-00-988-1727	96906	MS35206-283	SCREW, MACHINE UOC: FHQ	1
13	PAOZZ	5340-01-313-9469	81337	6-1-6261	BRACKET, MOUNTING UOC: FHQ	1
14	PAOZZ	5310-00-088-1251	96906	MS51922-1	NUT, SELF-LOCKING, HEAD	8
15	PAOZZ	5310-00-809-4058	96906	MS27183-10	WASHER, FLAT	8
16	PAOZZ	5340-01-468-5554	81337	6-1-6224	COVER, PROTECTIVE, DUST AND MOISTURE.....	1
17	XDOZZ		81337	6-1-6223	GASKET	1
18	PAOZZ	5305-00-068-0502	96906	MS90725-6	SCREW, CAP, HEXAGON HEAD	8
19	PAFFZ	5340-01-468-5537	81337	6-1-6259	HANDLE, BAIL	1
20	XDFZZ		81337	6-1-8071-1	. BRACKET.....	2
21	XDFZZ		81337	6-1-8071-2	. BRACKET.....	2
22	PAOZZ	4820-00-174-0339	96906	MS35782-3	COCK, DRAIN	1
23	PAOZZ	4730-00-948-1719	96906	MS27020-9	COUPLING HALF, QUICK DISCONNECT UOC: FHQ	1
24	XDOZZ		96906	MS35649-2382	NUT, PLAIN, HEXAGON	8
25	PDFFF	4410-01-203-0998	81337	6-1-6202	HEATER, WATER, LIQUID, VESSEL ASSEMBLY	1
26	PAOZZ	3990-01-374-0201	81337	6-1-6201	SKID, PLATFORM.....	1
					END OF FIGURE	

UNIT MAINTENANCE
HEATER, WATER, LIQUID FUEL M-80 AND M-85
(NSN 4520-01-162-0385 (M-80) NSN 4520-01-237-3719 (M-85))
UPPER AND LOWER MANIFOLD ASSEMBLY
REPAIR PARTS LIST

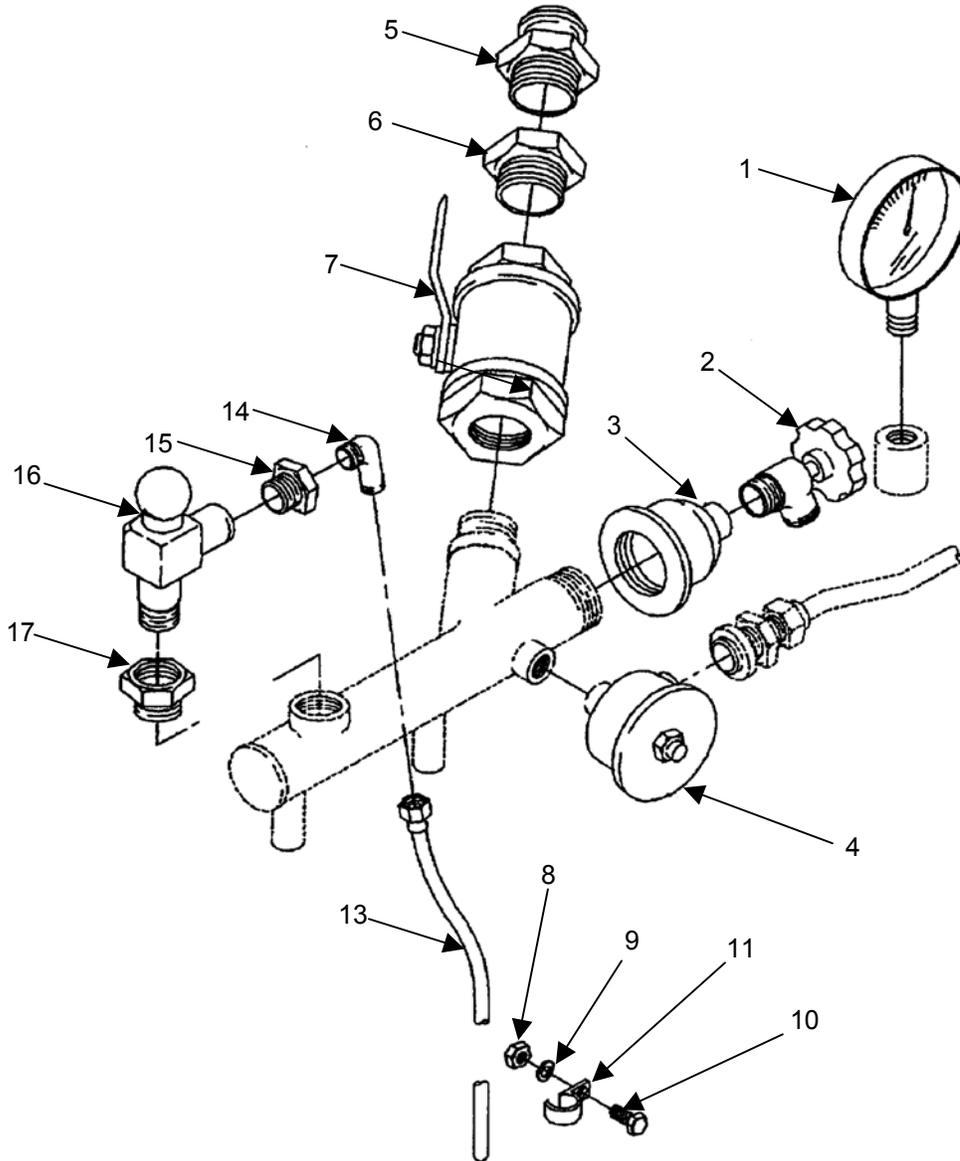

Figure 11. Upper (M80) Manifold Assembly
(Sheet 1 of 3)

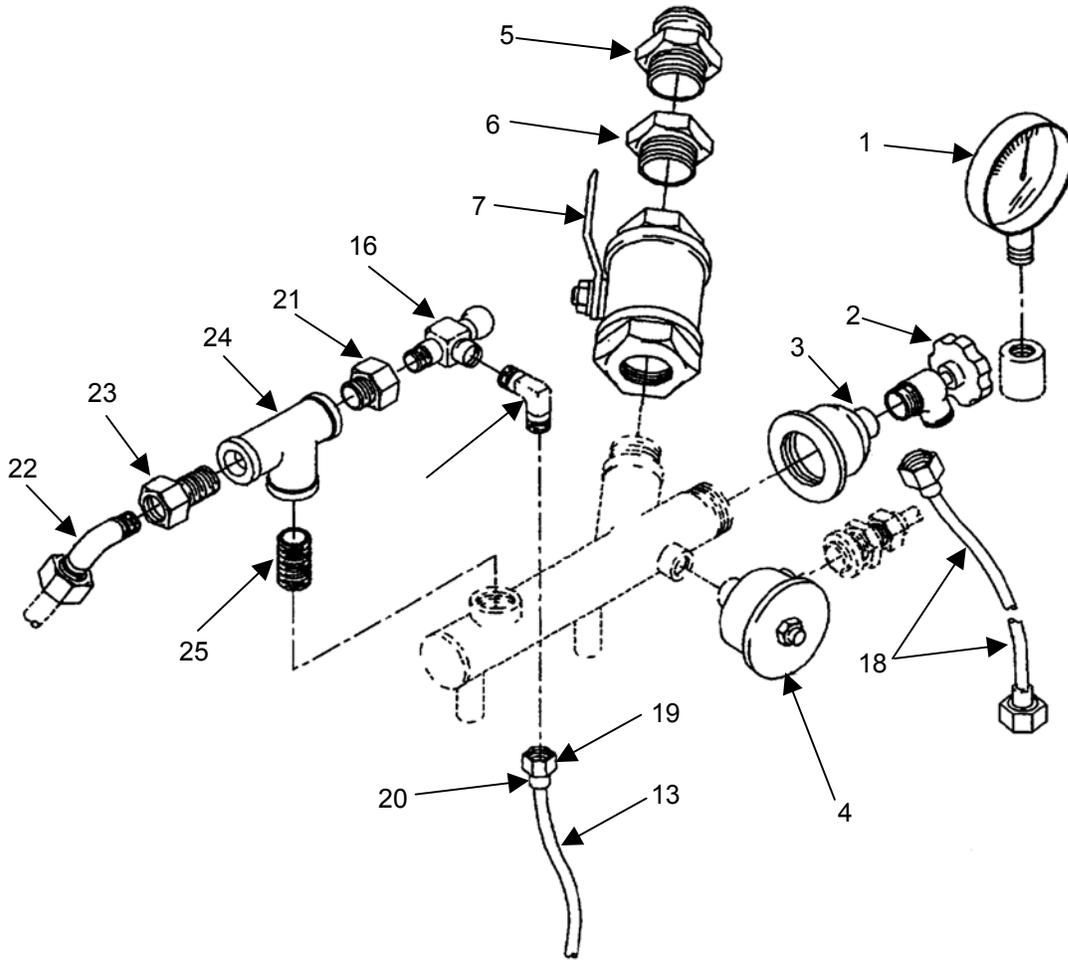

Figure 11. Upper (M85) Manifold Assembly
(Sheet 2 of 3)

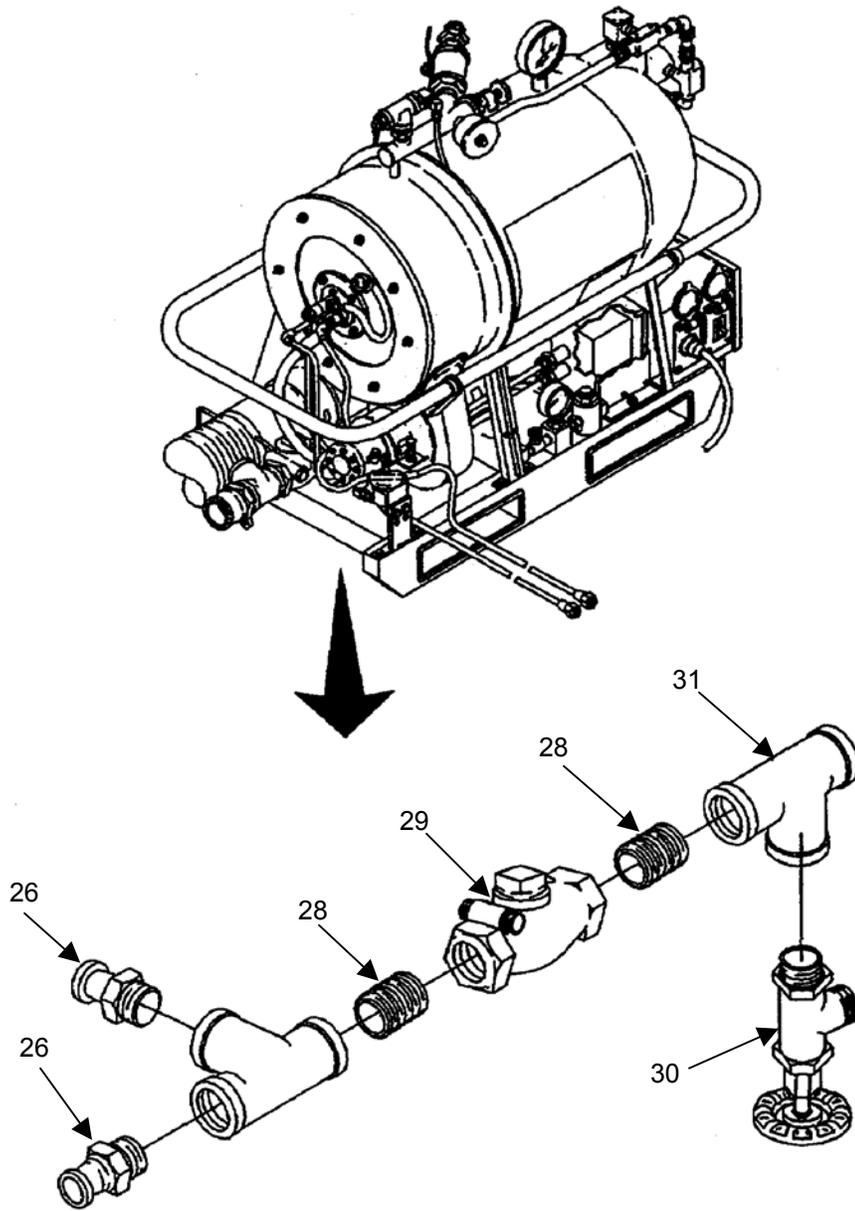

Figure 11. Lower Manifold Assembly
(Sheet 3 of 3)

(1)	(2)	(3)	(4)	(5)	(6)	(7)
ITEM NO.	SMR CODE	NSN	CAGEC	PART NUMBER	DESCRIPTION AND USABLE ON CODE (UOC)	QTY
					GROUP 0601 UPPER AND LOWER MANIFOLD ASSEMBLY	
					FIG. 11 UPPER AND LOWER MANIFOLD ASSEMBLY	
1	PBOZZ	6685-00-831-2740	61349	147869-T1050	THERMOMETER, SELF-INDICATING, BIMETAL	1
2	PAOZZ	4820-01-374-3674	81337	6-1-8117	VALVE, ANGLE	1
3	PAOZZ	4730-01-375-2265	81337	6-1-8104	REDUCER, PIPE	1
4	PBOZZ	5930-00-058-9344	81337	6-1-8121	SWITCH, THERMOSTATIC	1
5	PAOZZ	4730-00-084-7435	96906	MS27022-5	COUPLING, HALF, QUICK DISCONNECT	1
6	XDOZZ		96906	MS51847-19K	BUSHING, PIPE	1
7	PAOZZ	4820-01-163-9982	81337	6-1-6200-44	VALVE, BALL, WW-V-35, TY2, CLA STYLE 1, 1-1/2 NPT	1
8	XDOZZ		96906	MS35649-202	NUT, PLAIN HEXAGON UOC: FHQ	1
9	PAOZZ	5310-00-550-1130	96906	MS35333-40	WASHER, LOCK UOC: FHQ	1
10	PAOZZ	5303-00-939-9230	96906	MS35275-243	SCREW, MACHINE UOC: FHQ	1
11	PAOZZ	5340-00-764-7051	96906	MS21333-69	CLAMP, LOOP UOC: FHQ	1
12	XDOZZ		96906	MS39166-5L	NUT, TUBE COUPLING UOC: FHQ	1
13	XDOZZ		19207	12260274	TUBING, STEEL	1
14	XDOZZ		81343	SAE J 514 (070202)	ELBOW, MALE SAE J514 90 DEG, 3/8 TUBE X 1/2 NPT	1
15	XDOZZ		78468	5120	CONNECTOR, PLUG UOC: FHQ	1
16	PAOZZ	4820-01-218-8629	81337	6-1-8118	VALVE, SAFETY RELIEF	1
17	PAOZZ	4730-01-374-3641	81337	6-1-9337	BUSHING, PIPE UOC: FHQ	1
18	PBOZZ	4720-01-374-3705	90598	6-1-9912-15	HOSE ASSEMBLY, L, NONMETALLIC, W/ BRASS COUPLINGS UOC: FHR	1
19	PAOZZ	4730-00-203-3831	96906	MS51531-B6	NUT, TUBE COUPLING UOC: FHR	1
20	PAOZZ	4730-00-816-8558	96906	MS51533-B6	SLEEVE, FLARED TUBE UOC: FHR	1
21	PAOZZ	4730-01-374-3641	81337	6-1-9337	BUSHING, PIPE UOC: FHR	1
22	PAOZZ	4730-01-469-0991	81337	6-1-9912-21	ELBOW, PIPE TO TUBE, SAE J512, 5/16 TUBE X 1/4 NPT UOC: FHR	1
23	PAOZZ	4730-01-374-3638	81337	6-1-9912-20	BUSHING, PIPE, ANSI B16.14, 1X1/4, TY2	1
24	PAOZZ	4730-01-374-1494	81337	6-1-9912-19	TEE, PIPE, WW-P-521, 1 IN UOC: FHR	1
25	XDOZZ		96906	MS51953-121	NIPPLE, PIPE UOC: FHR	1

(1)	(2)	(3)	(4)	(5)	(6)	(7)
ITEM NO.	SMR CODE	NSN	CAGEC	PART NUMBER	DESCRIPTION AND USABLE ON CODE (UOC)	QTY
26	PAOZZ	4730-00-360-0589	96906	MS27022-9	COUPLING, HALF QUICK DISCONNECT UOC: FHR	2
27	PAOZZ	4730-01-374-3649	81337	6-1-9912-10	TEE, PIPE, WW-P-521, TY2, 1-1/2 X 1-1/2X1-1/2 IPS UOC: FHR	1
28	PAOZZ	4730-00-196-1471	96906	MS51953-169	NIPPLE, PIPE UOC: FHR	2
29	PAOZZ	4820-01-380-8544	76364	509	VALVE, CHECK UOC: FHR	1
30	PAOZZ	4820-01-374-3673	81337	6-1-9917	VALVE, ANGLE UOC: FHR	1
31	PAOZZ	4730-01-374-3648	81337	6-1-9912-3	TEE, PIPE UOC: FHR	1
END OF FIGURE						

UNIT MAINTENANCE
HEATER, WATER, LIQUID FUEL M-80 AND M-85
(NSN 4520-01-162-0385 (M-80) NSN 4520-01-237-3719 (M-85))
CONTROL BOX ASSEMBLY
REPAIR PARTS AND SPECIAL TOOLS LIST

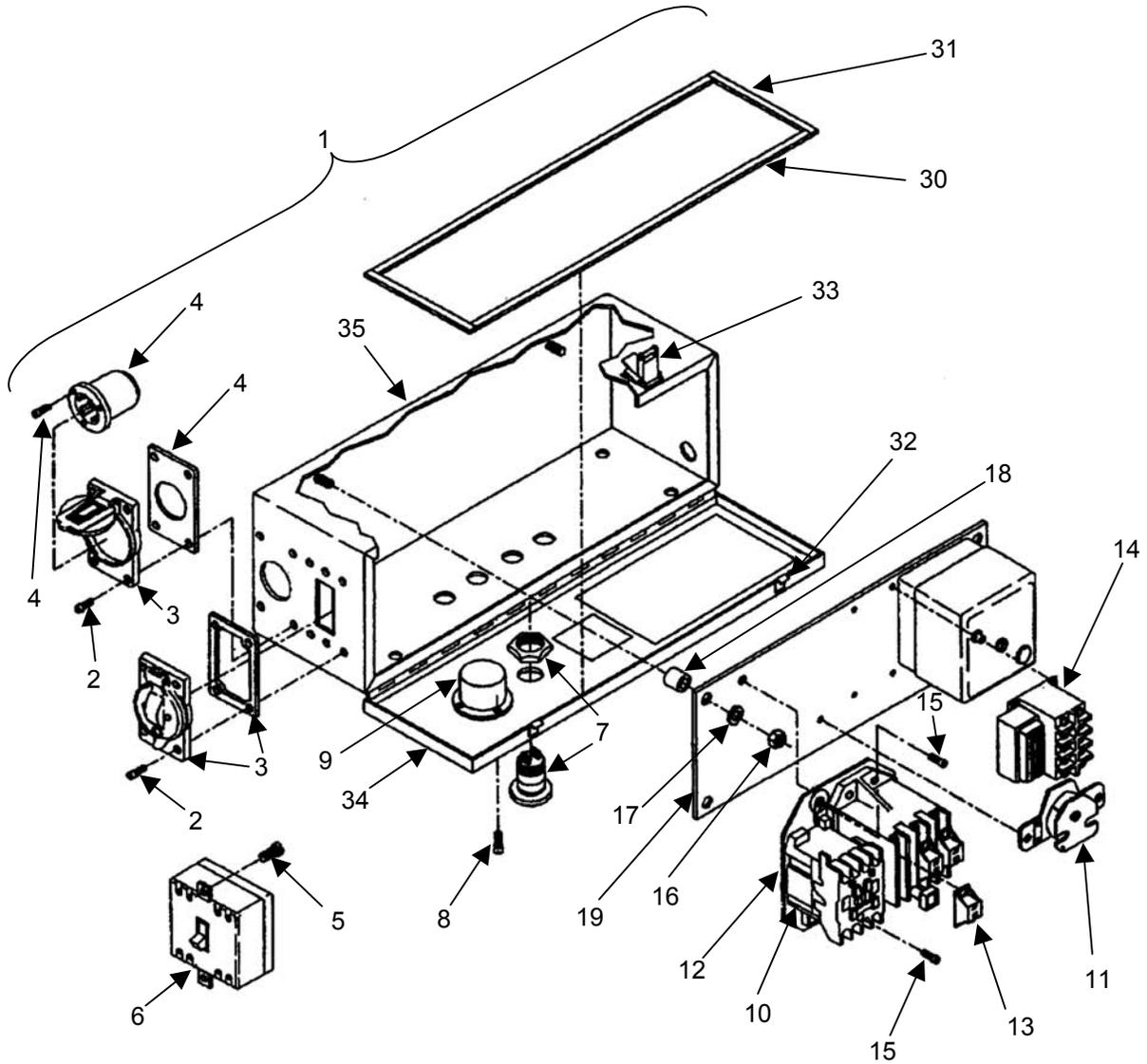

Figure 12. Control Box Assembly
(Sheet 1 of 2)

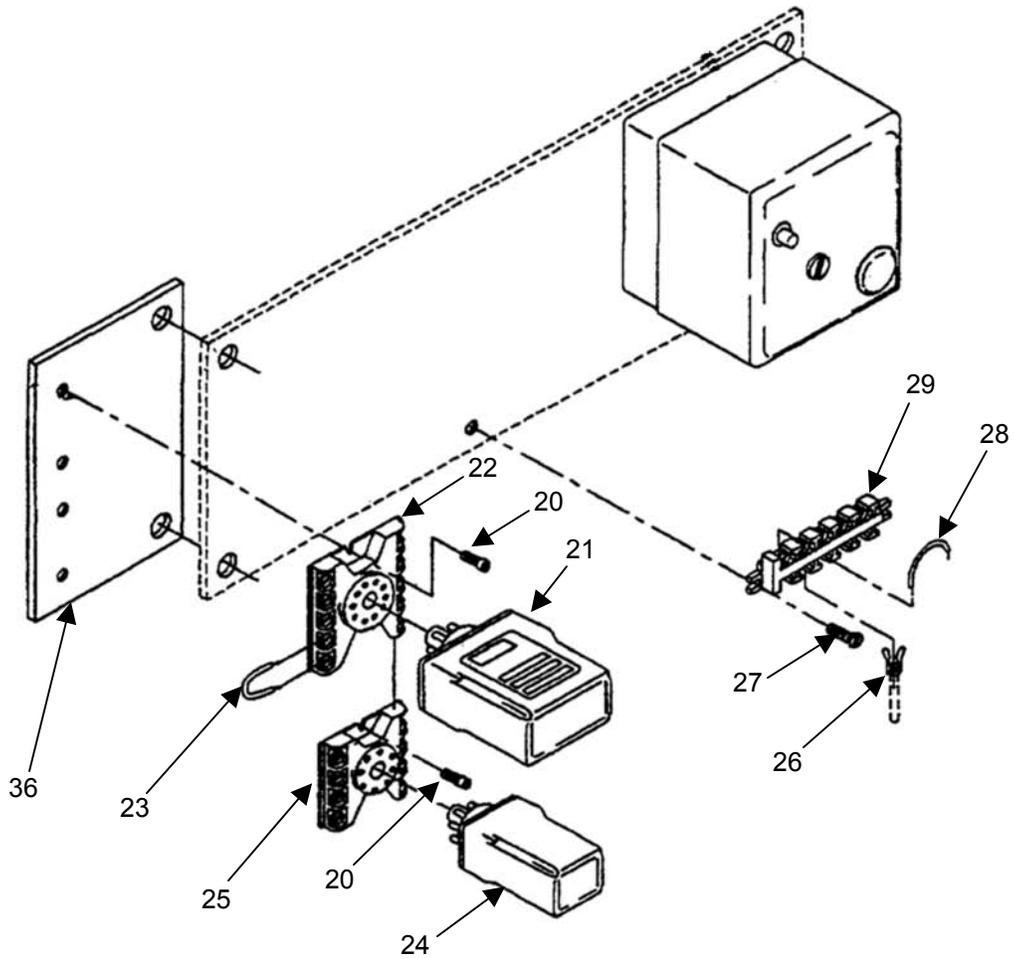

Figure 12. Control Box Assembly
(Sheet 2 of 2)

(1)	(2)	(3)	(4)	(5)	(6)	(7)
ITEM NO.	SMR CODE	NSN	CAGEC	PART NUMBER	DESCRIPTION AND USABLE ON CODE (UOC)	QTY
					GROUP 07 CONTROL BOX ASSEMBLY	
1	PBFFF	3510-01-440-6566	81337	6-1-9972	FIG. 12 CONTROL BOX ASSEMBLY CONTROL PANEL, LAUNDRY EQUIPMENT, M-85	
					UOC: FHR	1
1	XDFFF		81337	6-1-6250	BOX ASSY, CONTROL, M-80	
					UOC: FHQ	1
2	PAFZZ	5305-00-925-4777	96906	MS35275-231	. SCREW, MACHINE.....	8
3	PAFZZ	5975-00-840-5844	74545	7420	. COVER, CONDUIT OUTLET	1
4	PAFZZ	5935-01-213-0383	81348	WC596/139-1	. CONNECTOR, RECEPTACLE.....	1
5	XDFZZ	5305-00-925-4777	96906	MS35275-231	. SCREW, MACHINE.....	2
6	XDFZZ	5930-01-037-6229	07442	2510K0-2	. SWITCH, TOGGLE.....	1
7	XDFZZ	6350-00-906-2446	90201	SC110	BUZZER	
					UOC: FHR	2
8	XDFZZ	5303-00-941-9437	96906	MS35275-215	. SCREW, MACHINE.....	3
9	PBFZZ	6645-00-831-6826	81349	M3791/2-005	. METER, TIME TOTALIZING	1
10	XDFZZ		81349	LP01LL04	. TERMINAL, LUG	1
11	PAFZZ	6530-01-373-7939	75203	231	. BUZZER	1
12	PAFZZ	6110-01-013-6482	01121	509-TOD/W-39	. STARTER, MOTOR.....	1
13	PAFZZ	4520-01-237-8038	01121	W-39	. ELEMENT, HEATER	8
14	PAFZZ	5945-01-155-8680	79198	1D1E0	. RELAY, ELECTROMAGNET (LOW WATER)	1
15	PAFZZ	5305-00-939-9230	96906	MS35275-243	. SCREW, MACHINE.....	32
16	PAFZZ	5310-00-997-1888	96906	MS35649-2252	. NUT, PLAIN, HEXAGON	4
17	PAFZZ	5310-00-809-4058	96906	MS27183-10	. WASHER, FLAT	4
18	XDFZZ		81337	6-1-6254	. SPACER.....	4
19	PAFZZ	5340-01-468-8321	81337	6-1-6253	. PLATE, MOUNTING.....	1
20	PAFZZ	5305-00-701-5061	96906	MS51958-45	. SCREW, MACHINE	
					UOC: FHR	8
21	PAFZZ	5945-00-497-7627	77342	CHB38-70013	. RELAY, SOLID STATE (K-1)	
					UOC: FHR	1
22	PAFZZ	5935-01-140-8059	77342	27E122	SOCKET, PLUG IN ELECTRONIC COMPONENT	
					UOC: FHR	1
23	XDFZZ		72962	10	. BUS, CONDUCTOR	
					UOC: FHR	1
24	PAOZZ	5945-00-787-3068	04071	R350016-3	. RELAY, ELECTROMAGNET (K-2)	
					UOC: FHR	1
25	PAFZZ	5935-01-052-9171	77342	27E123	. SOCKET, PLUG-IN ELECTRONIC COMPONENT	
					UOC: FHR	1
26	PAFZZ	5940-01-020-2022	00779	52955	. TERMINAL LUG	21
27	PAFZZ	5305-00-939-9232	96906	MS35275-246	. SCREW, MACHINE.....	6
28	PAFZZ	5999-01-202-6585	89020	70	. CONTACT, ASSEMBLY, ELECTRICAL..	1
29	PAFZZ	6150-01-373-8064	81349	MS5164/2- 38TB6	. BUS, CONDUCTOR.....	6
30	PAFZZ	5330-01-468-9959	81337	6-1-8067-1	. GASKET, 23.06 IN LG.....	2
31	PAFZZ	5330-01-468-9954	81337	6-1-8067-2	. GASKET, 6.94 IN LG.....	2

(1)	(2)	(3)	(4)	(5)	(6)	(7)
ITEM NO.	SMR CODE	NSN	CAGEC	PART NUMBER	DESCRIPTION AND USABLE ON CODE (UOC)	QTY
32	PAFZZ	5340-00-178-7870	96906	MS18015-2	. LATCH.....	2
33	PAFZZ	5340-00-237-6254	96906	MS18015-3	. STRIKE, CATCH.....	2
34	XDFZZ		81337	6-1-6252	. COVER, DISTRIBUTION.....	1
35	XDFZZ		81337	6-1-6251	. JUNCTION BOX.....	1
36	PAFZZ	5340-01-468-8335	81337	6-1-8790	. PLATE, MOUNTING.....	1
END OF FIGURE						

**UNIT MAINTENANCE
HEATER, WATER, LIQUID FUEL M-80 AND M-85
(NSN 4520-01-162-0385 (M-80) NSN 4520-01-237-3719 (M-85))
UV AND IR FLAME SAFEGUARD CONTROL
REPAIR PARTS LIST**

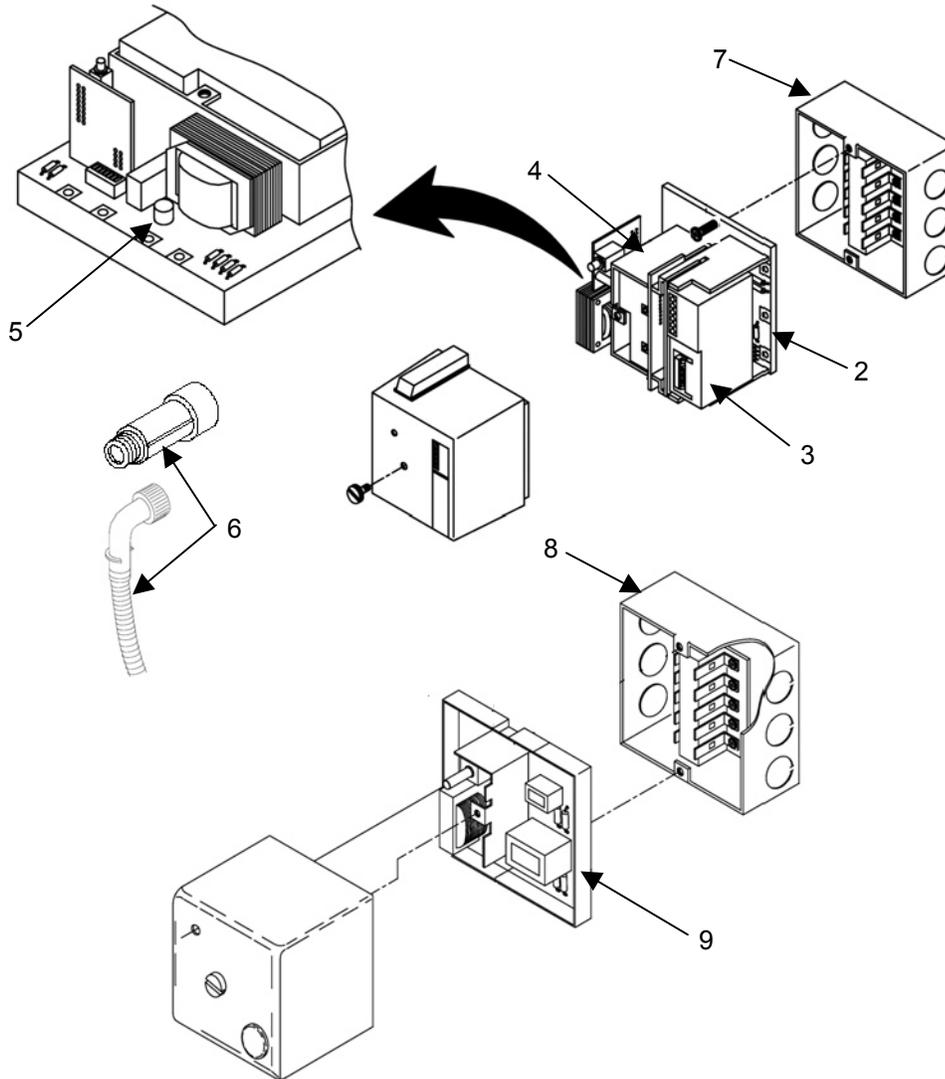

Figure 13. UV and IR Flame Safeguard Control

(1)	(2)	(3)	(4)	(5)	(6)	(7)
ITEM NO.	SMR CODE	NSN	CAGEC	PART NUMBER	DESCRIPTION AND USABLE ON CODE (UOC)	QTY
					GROUP 0701 UV AND IR FLAME SAFEGUARD CONTROL	
1	PAOOO	6150-01-497-0505	81337	PL6-1-8949-1	FIG. 13 UV AND IR FLAME SAFEGUARD CONTROL MODIFICATION KIT, ELECTRIC POWER AND DISTRIBUTION EQUIPMENT, CONVERSION OF FLAME CONTROLLER FROM UV TO IR .	1
2	PAOOO	6695-01-496-4749	72144	MEC120D	CONTROL, INDICATOR, MODULAR CHASSIS, 120 VOLT, IR	1
3	PAOZZ	5998-01-496-3870	72144	MEP230	CIRCUIT CARD ASSEMBLY, PROGRAMMER MODULE FOR IR CONTROLLER	1
4	PAOZZ	5998-01-496-5834	72144	MEIR4	CIRCUIT CARD ASSEMBLY, INFRARED AMPLIFIER MODULE FOR IR CONTROLLER.....	1
5	XDOZZ		72144	23-197	FUSE, 10 AMP	1
6	PAOZZ	5980-01-145-7162	72114	48PT2-9003	PHOTOELECTRIC CELL, IR FLAME SCANNER WITH HEAT INSULATOR, USE WITH IR CONTROL ONLY	1
7	PAFZZ	5940-01-313-9892	72144	61-3060	. TERMINAL BOX.....	1
8	PAOZZ	6645-01-159-8787	72144	MT710	. PROGRAM TIME CARD, UV FLAME CONTROL ONLY	1
9	PAFZZ	4540-01-230-8586	72144	UVM-2	. CONTROL, FLAME SAFEGUARD, UV, ORDER CONVERSION KIT P/N 6-1-8949-1	1
					END OF FIGURE	

UNIT MAINTENANCE
HEATER, WATER, LIQUID FUEL M-80 AND M-85
(NSN 4520-01-162-0385 (M-80) NSN 4520-01-237-3719 (M-85))
DRUM FILL ADAPTER ASSEMBLY
REPAIR PARTS LIST

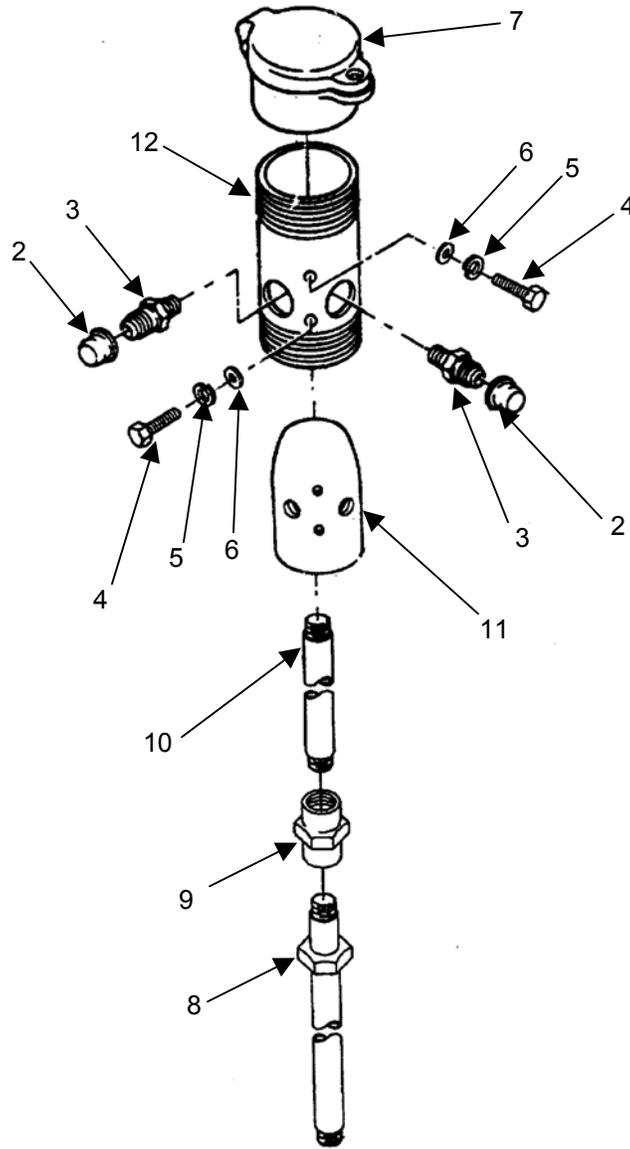

Figure 14. Drum Fill Adapter Assembly

(1)	(2)	(3)	(4)	(5)	(6)	(7)
ITEM NO.	SMR CODE	NSN	CAGEC	PART NUMBER	DESCRIPTION AND USABLE ON CODE (UOC)	QTY
					GROUP 08 DRUM FILL ADAPTER ASSEMBLY	
					FIG. 14 DRUM FILL ADAPTER ASSEMBLY	
1	PAOOZ	4510-01-214-9139	81337	6-1-8285	ADAPTER ASSEMBLY	1
2	PAOZZ	5340-01-230-4467	81349	M55501/3-R8	. CAP, PROTECTIVE, DUST.....	2
3	XDOZZ		88044	AN816-7B	. ADAPTER, STRAIGHT, PIPE	2
4	PAOZZ	5305-00-068-0502	96906	MS90725-6	. SCREW, CAP, HEXAGON, HEAD	2
5	PAOZZ	5310-00-582-5965	96906	MS35338-44	. WASHER, LOCK	2
6	PAOZZ	5310-00-823-8804	96906	MS27183-9	. WASHER, FLAT	2
7	PAOZZ	5430-01-374-3719	9V329	6-1-8288	. CAP, FILLER, OPENING.....	1
8	PBOZZ	4710-01-374-3761	90598	6-1-8281	. PIPE ASSEMBLY, METAL	1
9	XDOZZ		81349	J926 (140138)	. COUPLING, PIPE.....	1
10	PAOZZ	4730-01-387-4602	81337	6-1-8279	. ADAPTER, STRAIGHT, PIPE	1
11	XDOZZ		81337	6-1-8287	. BLOCK, MOUNTING	1
12	PAOZZ	4730-01-374-3644	81337	6-1-8286	. NIPPLE, PIPE.....	1
					END OF FIGURE	

**HEATER, WATER, LIQUID FUEL M-80 AND M-85
NATIONAL STOCK NUMBER (NSN) INDEX**

STOCK NUMBER	FIG.	ITEM	STOCK NUMBER	FIG.	ITEM
4730-00-028-3862	9	27	5310-00-576-5752	7	8
5310-00-037-4935	8	12	5310-00-582-5965	10	11
	9	15		14	5
5930-00-058-9344	11	4	5310-00-595-7237	6	5
5305-00-068-0502	1	8		10	3
	4	8	5315-00-619-7158	6	22
	7	17	5305-00-701-5061	12	20
	10	18	4320-00-707-4851	6	17
	14	4	4530-00-707-5965	2	20
4730-00-084-7435	11	5	5975-00-707-6229	4	3
5310-00-088-1251	10	14		6	3
4820-00-174-0339	10	22	5330-00-718-6547	8	8
5340-00-178-7870	12	32		9	10
4730-00-196-1467	2	15	5305-00-723-9386	6	18
4730-00-196-1471	11	28	5305-00-723-9398	2	23
4730-00-196-1538	2	22	5310-00-761-6882	2	4
4730-00-203-3831	11	19		10	10
5331-00-218-0390	8	27	5340-00-764-7051	11	11
5305-00-225-3843	7	14	5945-00-787-3068	12	24
5340-00-237-6254	12	33	5310-00-809-4058	7	15
5305-00-240-6668	7	9		10	15
4730-00-251-1010	9	26		12	17
5303-00-269-3211	6	4	4730-00-816-8558	11	20
4730-00-278-3678	6	15	5310-00-823-8804	14	6
4730-00-287-1024	6	11	6685-00-831-2740	11	1
4820-00-287-2784	1	5	6645-00-831-6826	12	9
4730-00-360-0589	11	26	5975-00-840-5844	12	3
5330-00-360-5303	7	4	6685-00-851-6818	1	7
5310-00-374-6103	9	28	6350-00-906-2446	12	7
5330-00-374-6104	9	30	4730-00-921-3624	1	10
5330-00-375-1690	8	3	5305-00-925-4777	12	2
	9	3		12	5
4320-00-432-1691	6	17	5305-00-939-9230	11	10
4730-00-433-3375	1	3		12	15
5950-00-454-5463	4	7	5305-00-939-9232	12	27
4330-00-461-3964	9	5	5305-00-941-9437	12	8
5330-00-467-3553	2	10	4730-00-948-1719	10	23
5330-00-472-6189	8	15	5303-00-948-4037	2	2
	9	19	5330-00-953-4407	8	23
5310-00-472-6204	8	14	5305-00-958-5260	6	6
	9	18	4520-00-976-2253	8	11
5360-00-472-6224	9	29		9	13
5330-00-482-7051	8	24	5305-00-984-6212	7	12
6685-00-492-6230	1	6	5305-00-988-1727	10	12
5945-00-497-7627	12	21	5975-00-995-5260	4	2
5330-00-527-7560	8	10	5310-00-997-1888	4	5
	9	12		7	12
5310-00-550-1130	1	9		10	7
5310-00-550-1130	2	5		12	16
	4	6	4320-01-006-4734	9	14
	7	13	6110-00-013-6482	12	12
	10	8	5940-01-020-2022	12	26
	11	9	5340-01-030-4467	14	2

STOCK NUMBER	FIG.	ITEM	STOCK NUMBER	FIG.	ITEM
5930-01-037-6229	12	6	4730-01-374-3649	11	27
5935-01-052-9171	12	25	3010-01-374-3657	6	19
5935-01-140-8059	12	22	5330-01-374-3662	10	9
5980-01-145-7162	13	6	4820-01-374-3673	11	30
5945-01-155-8680	12	14	4820-01-374-3674	11	2
6645-01-159-8787	13	8	4730-01-374-3676	4	4
5977-01-161-6680	5	10	4720-01-374-3705	11	18
5977-01-161-8056	5	11	5340-01-374-3719	14	7
4820-01-163-9982	11	7	4710-01-374-3725	2	18
4810-01-170-2433	1	13	4710-01-374-3761	14	8
4530-01-180-2000	2	7	4730-01-375-2229	10	6
5999-01-202-6585	12	28	4730-01-375-2265	11	3
4410-01-203-0998	10	25	4140-01-375-2270	6	10
6105-01-211-6845	7	9	4520-01-375-2279	2	19
5935-01-213-0383	12	4	4720-01-375-2299	2	3
4510-01-214-9139	14	1	4730-01-375-5258	1	11
4520-01-218-8575	2	8	4320-01-376-0423	1	15
4820-01-218-8629	11	16	4820-01-380-8544	11	29
6150-01-219-8696	4	10	4730-01-387-4602	14	10
4520-01-227-1618	2	9	3510-01-440-6566	12	1
4540-01-230-8586	13	9	3510-01-440-8911	6	1
4520-01-237-8038	12	13	5670-01-441-4500	6	21
4330-01-278-3614	7	1	2910-01-466-5246	7	5
4520-01-306-2057	3	2	5340-01-468-5416	6	7
6680-01-306-2079	10	1	5340-01-468-5423	6	26
4520-01-306-2111	3	3	5340-01-468-5430	6	28
4520-01-311-0900	3	4	5340-01-468-5537	10	19
5340-01-313-9469	10	13	5340-01-468-5550	2	11
5940-01-313-9892	13	7	5340-01-468-5554	10	16
4730-01-321-9921	7	11	5340-01-468-6667	4	9
4330-01-356-0850	6	12	4140-01-468-6724	6	29
	7	3	5315-01-468-6808	6	27
6685-01-357-7533	5	7	5315-01-468-6827	6	8
6530-01-373-7939	12	11	5340-01-468-7710	7	16
6150-01-373-8064	12	29	5340-01-468-8321	12	19
5330-01-373-9758	10	4	5360-01-468-8792	6	25
3990-01-374-0201	10	26	5330-01-468-9954	12	31
4710-01-374-0238	1	1	5330-01-468-9959	12	30
4730-01-374-1494	11	24	4710-01-469-0587	2	14
5330-01-374-1501	2	12	4730-01-469-0991	11	22
4730-01-374-3633	6	16	4710-01-469-1237	1	14
4730-01-374-3638	11	23	5977-01-469-8946	2	24
4730-01-374-3639	2	17	5998-01-496-3870	13	3
4730-01-374-3641	11	17	6695-01-496-4749	13	2
	11	21	5998-01-496-5834	13	4
4730-01-374-3644	14	12	6150-01-497-0505	13	1
4730-01-374-3648	11	31			

HEATER, WATER, LIQUID FUEL M-80 AND M-85
PART NUMBER INDEX

PART NUMBER	FIG.	ITEM	PART NUMBER	FIG.	ITEM
AN816-7B	14	3		14	5
A733S-6CFG	1	10	MS35649-202	7	7
B-0604	6	4	MS35649-202	11	8
B1821BH025C100N	7	14	MS35649-2252	4	5
CHB38-70013	12	21		7	12
H3BA100	6	17		10	7
J3BA-178P	6	17		12	16
J926 (140138)	14	9	MS35649-2382	10	24
LP01L004	12	10	MS35782-3	10	22
MEC120D	13	2	MS39166-5L	11	12
MEIR4	13	4	MS51500-B8S	7	10
MEP230	13	3	MS51504-A5Z	1	4
MIL-C-13909C TYPE 1	4	1	MS51504-B8-4Z	6	14
GRADE B			MS51506A5Z	2	21
MS14304-2C08	2	16	MS51531-B5Z	1	2
MS15795-910	6	23	MS51531-B6	11	19
MS18015-2	12	32	MS51533-B6	11	20
MS18015-3	12	33	MS5164/2-38TB6	12	29
MS20819-5	1	3	MS51847-19K	11	6
MS20822-5D	6	15	MS51849-78	7	9
MS20822-8D	6	11	MS51922-1	10	14
MS21333-69	11	11	MS51953-121	11	25
MS27020-9	10	23	MS51953-169	11	28
MS27022-5	11	5	MS51953-17	2	22
MS27022-9	11	26	MS51953-75	5	6
MS27183-10	7	15	MS51958-45	12	20
	10	15	MS51963-47	2	23
	12	17	MS51963-64	6	18
MS27183-9	14	6	MS51967-2	2	4
MS35190-321	6	6		10	10
MS35206-265	7	2	MS90725-6	1	8
MS35206-283	10	12		4	8
MS35275-215	12	8		7	17
MS35275-231	12	2		10	18
	12	5		14	4
MS35275-243	11	10	MS90725-60	10	2
	12	15	MS90725-61	6	20
MS35275-246	12	27	MS90725-8	10	5
MS35275-259	2	2	MS9245-25	6	22
MS35333-39	7	8	MT710	13	8
MS35333-40	1	9	M3791/2-005	12	9
	2	5	M5501/3-R8	14	2
	4	6	M55164/2-38TB6	12	29
	7	13	M674	2	10
	10	8	PL6-1-8949-1	13	1
	11	9	R350016-3	12	24
MS35333-42	6	5	SAE J 514 (070202)	11	14
	10	3	SC110	12	7
MS35338-44	10	11	T1-10	4	7
			UVM-2	13	9

PART NUMBER	FIG.	ITEM	PART NUMBER	FIG.	ITEM
W-39	12	13	129792	8	25
WC596/139-1	12	4	131129	9	4
1D1EO	12	14	131596	8	2
10	12	23	131622	8	4
100031	9	27	134122	9	6
100241	8	14	134137	9	7
	9	18	147869-T1050	11	1
100291	9	28	168662	2	7
100301	9	29	170070	9	33
100319	9	30	2021-6-4C	7	11
100371	8	15	2024A-2-5S	1	5
	9	19	22342-00	7	5
100901	8	10	23-021110-000	5	7
	9	12	23-197	13	5
100931	8	17	231	12	11
	9	22	24800	8	21
101001	9	20		9	25
101641	9	23	25SE	1	7
101861	9	31	2510K0-2	12	6
102825	2	15	25815	8	12
103379	8	16		9	15
	9	21	27E122	12	22
104671	8	5	27E123	12	25
109026	9	32	28329-00	7	6
109777	9	11	3R1B0	5	11
110441	8	3	32845-31	7	4
	9	3	3729241	9	26
111401	8	1	3759231	8	20
	9	1		9	24
113331	8	8	48PT2-9003	13	6
	9	10	48365	1	6
114227	8	9	5K33FN311U	6	9
115462	8	24	509	11	29
116106	8	19	509-TOD/W-39	12	12
117531	8	7	51017	8	22
117667	8	28	5120	11	15
120353	9	2	52955	12	26
121222	8	13	5331	4	3
121732	8	11		6	3
	9	13	5351	4	2
12260274	11	13	6-1-6200-28	5	2
122822	9	5	6-1-6200-29	5	1
124027	8	6	6-1-6200-30	5	3
125122	8	27	6-1-6200-31	5	4
125132	8	23	6-1-6200-32	5	5
12706-02-20-0035	7	3	6-1-6200-33	1	15
128283	9	9	6-1-6200-44	11	7
128403	9	16	6-1-6200-52	1	16
128433	9	17	6-1-6201	10	26
128527	9	8	6-1-6202	10	25
129521	8	26	6-1-6223	10	17

PART NUMBER	FIG.	ITEM	PART NUMBER	FIG.	ITEM
6-1-6224	10	16	6-1-8102	5	10
6-1-6225-101	6	1	6-1-8104	11	3
6-1-6225-14	6	2	6-1-8110	1	12
6-1-6226	6	29	6-1-8117	11	2
6-1-6227	6	7	6-1-8118	11	16
6-1-6228	6	21	6-1-8121	11	4
6-1-6229	6	28	6-1-8122	5	9
6-1-6230	6	26	6-1-8259	3	1
6-1-6231	6	27	6-1-8260	3	4
6-1-6232	6	24	6-1-8263	3	3
6-1-6233	6	25	6-1-8264	3	2
6-1-6234	6	8	6-1-8279	14	10
6-1-6235	10	4	6-1-8281	14	8
6-1-6236	2	1	6-1-8285	14	1
6-1-6237	2	6	6-1-8286	14	12
6-1-6238-14	2	17	6-1-8287	14	11
6-1-6239	2	24	6-1-8288	14	7
6-1-6240-1	2	8	6-1-9336	4	4
6-1-6240-2	2	9	6-1-9337	11	17
6-1-6241	2	14		11	21
6-1-6242	2	11	6-1-9912-10	11	27
6-1-6243	2	13	6-1-9912-15	11	18
6-1-6244	2	12	6-1-9912-19	11	24
6-1-6245	2	18	6-1-9912-20	11	23
6-1-6247	2	3	6-1-9912-21	11	22
6-1-6248	10	1	6-1-9912-3	11	31
6-1-6250	12	1	6-1-9917	11	30
6-1-6251	12	35	6-1-9972	12	1
6-1-6252	12	34	6-2-2454	2	1
6-1-6253	12	19	6-2-2461	2	14
6-1-6254	12	18	6-2-2462	2	20
6-1-6255	7	18	61-3060	13	7
6-1-6256	7	16	631-200S	6	10
6-1-6257	1	11	68514444829	6	19
6-1-6258	4	9	70	12	28
6-1-6259	10	19	71215SN1KNOONOC11	1	13
6-1-6260	10	9	1P3		
6-1-6261	10	13	728335	8	18
6-1-6262	10	6	7420	12	3
6-1-6263	4	10	89975K25	1	14
6-1-7494	1	1	98801-01	7	1
6-1-8040	6	12	991096	9	14
6-1-8042	2	20			
6-1-8043	2	19			
6-1-8067-1	12	30			
6-1-8067-2	12	31			
6-1-8071-1	10	20			
6-1-8071-2	10	21			
6-1-8094	5	8			
6-1-8095	6	16			
6-1-8097	6	13			

**HEATER, WATER, LIQUID FUEL, M-80 AND M-85
COMPONENTS OF END ITEM (COEI) AND BASIC ISSUE ITEMS (BII) LISTS**

Scope

This work package lists COEI and BII for the water heater to help you inventory items for safe and efficient operation of the equipment.

General

The COEI and BII information is divided into the following lists:

Components of End Item (COEI). This list is for information purposes only and is not authority to requisition replacements. These items are part of the M-80 and M-85. As part of the end item, these must be with the end item whenever it is issued or transferred between property accounts. Items of COEI are removed and separately packaged for transportation or shipment only when necessary. Illustrations are furnished to help you find and identify the items.

Basic Issue Items (BII). These essential items are required to place the M-80 and M-85 in operation, operate it, and to do emergency repairs. Although shipped separately packaged, BII must be with the M-80 and M-85 during operation and when it is transferred between property accounts. Listing these items is your authority to request / requisition them for replacement based on authorization of the end item by the TOE/MTOE. Illustrations are furnished to help you find and identify the items.

Explanation of Columns in the COEI List and BII List

Column (1), Illu Number, gives you the number of the item illustrated.

Column (2), National Stock Number, identifies the stock number of the item to be used for requisitioning purposes.

Column (3), Description, CAGEC, and Part Number, identifies the Federal item name (in all capital letters) followed by a minimum description when needed. The stowage location of COEI and BII is also included in this column. The last line below the description is the CAGEC (commercial and Government entity code) (in parenthesis) and the part number.

Column (4), Usable on Code, gives you a code if the item you need is not the same for different models of equipment. The codes are as follows:

<u>CODE</u>	<u>USED ON</u>
FHQ	M-80
FHR	M-85

Column (5), U/M (unit of measure), indicates how the item is issued for the National Stock Number shown in column 2.

Column (6), Qty Rqr, indicates the quantity required.

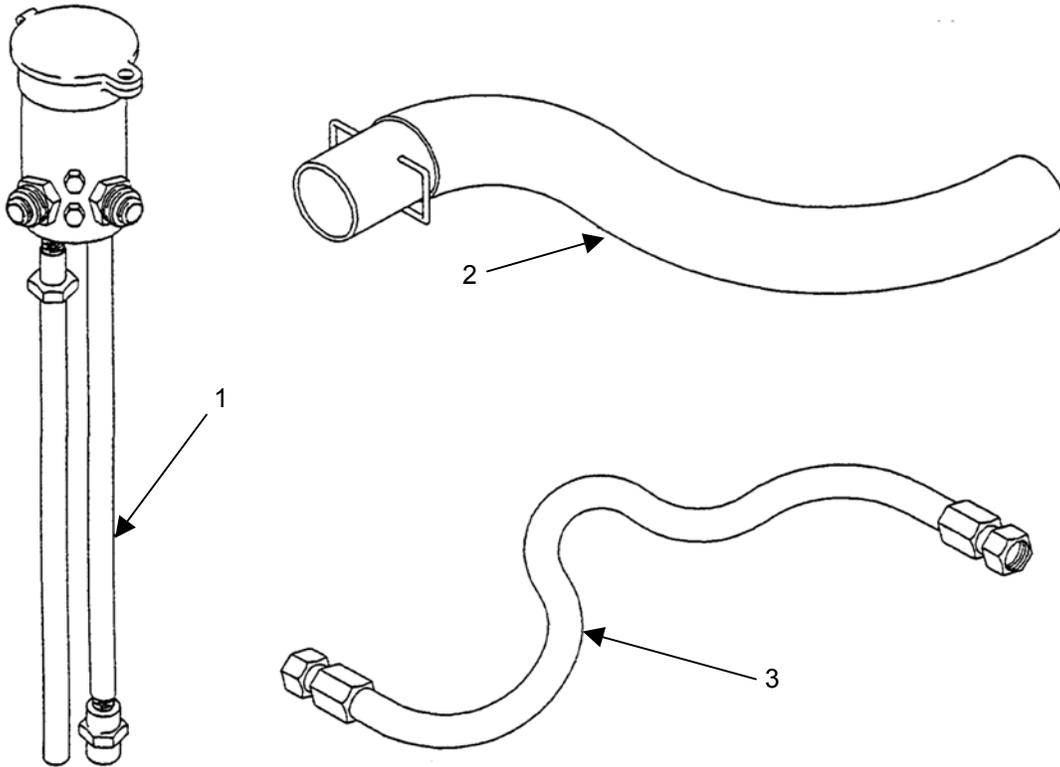

Table 1. Components of End Item List.

(1) ILLUS NUMBER	(2) NATIONAL STOCK NUMBER	(3) DESCRIPTION, CAGEC AND PART NUMBER	(4) USABLE ON CODE	(5) U/M	(6) QTY RQR
1	4510-01-214-9139	Drum Fill Adapter Assembly, Type II, 6-1-8285 (81337)		EA	1
2	4720-01-375-5445	Duct, Burner Exhaust Assembly, 6-2-2427 (81337)	FHR	EA	1
3	4720-00-063-7222	Hose, Fuel Return, 12 Foot, MS 28741-8-1440 (96906)		EA	1

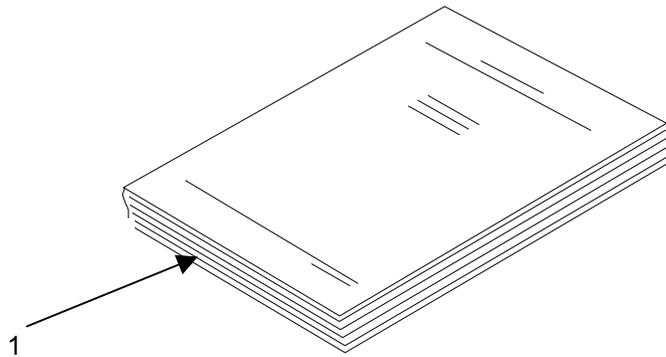

Table 2. Basic Issue Items List.

(1) ILLUS NUMBER	(2) NATIONAL STOCK NUMBER	(3) DESCRIPTION, CAGEC AND PART NUMBER	(4) USABLE ON CODE	(5) U/M	(6) QTY RQR
1	N/A	TM 10-4520-259-13&P, Operator's, Unit and Direct Support Maintenance Manual Including Repair Parts and Special Tools List for Heater, Water Liquid Fuel		EA	1

**HEATER, WATER, LIQUID FUEL, M-80 AND M-85
ADDITIONAL AUTHORIZATION LIST (AAL)**

INTRODUCTION

This work package lists additional items you are authorized for the support of the water heater.

General

This list identifies items that do not have to accompany the water heater and that do not have to be turned in with it. These items are all authorized to you by CTA, MTOE, TDA, or JTA.

Explanation of Columns in the AAL

Column (1), National Stock Number, identifies the stock number of the item to be used for requisitioning purposes.

Column (2), Description, CAGEC, and Part Number, identifies the Federal Item Name (in all capital letters) followed by a minimum description when needed. The last line below the description is the CAGE (Commercial and Government Entity Code) (in parenthesis) and the part number.

Column (3), Usable On Code, when applicable, gives you a code if the item you need is not the same for different models of equipment.

Column (4), U/M (unit of measure), indicates how the item is issued for the National Stock Number shown in column (1).

Column (5), Qty Recm. indicates the quantity recommended.

ADDITIONAL AUTHORIZED LIST ITEMS**Table 1. Additional Authorization List.**

(1) NATIONAL STOCK NUMBER	(2) DESCRIPTION, CAGEC AND PART NUMBER	(3) USABLE ON CODE	(4) U/M	(5) QTY RECM
5120-00-240-5328	Wrench, Open End, Adjustable, 8 Inch		EA	2

**HEATER, WATER, LIQUID FUEL, M-80 AND M-85
EXPENDABLE AND DURABLE ITEMS LIST**

INTRODUCTION

This work package lists expendable and durable items that you will need to operate and maintain the water heater. This list is for information only and is not authority to requisition the listed items. These items are authorized to you by CTA 50-970, Expendable/Durable Items (Except Medical, Class V Repair Parts, and Heraldic Items), or CTA 8-100, Army Medical Department Expendable/Durable Items.

Explanations of Columns in the Expendable / Durable Items List

Column (1)-Item Number. This number is assigned to the entry in the list and is referenced in the narrative instructions to identify the item (e.g., "Use brake fluid (item 5, WP 0098 00)").

Column (2)-Level. This column includes the lowest level of maintenance that requires the listed item (C= Operator/Crew).

- C** -Operator or Crew
- O** -Unit Maintenance
- F** -Direct Support Maintenance
- H** -General Support Maintenance
- D** -Depot Maintenance

Column (3)- National Stock Number. This is the NSN assigned to the item which you can use to requisition it.

Column (4)- Item Name, Description, Commercial and Government Entity Code (CAGE), and Part Number (P/N). This column provides the other information you need to identify the item.

Column (5)- Unit of Measure (U/M). This code shows the physical measurement or count of an item such as gallon, dozen, gross, etc.

EXPENDABLE AND DURABLE ITEMS LIST

Table 1. Expendable and Durable Items List.

(1) ITEM NUMBER	(2) LEVEL	(3) NATIONAL STOCK NUMBER	(4) ITEM NAME, DESCRIPTION, CAGEC, PART NUMBER	(5) U/M
1	C, O, F	7920-00-292-9204	Cloth, Cleaning CCC-C-46 (81349)	BAL
2	O, F	8030-01-009-2590	Compound, Antisieze (08854)	EA
3	O, F	6850-00-656-1292	Compound, Cleaning MIL-C-10578, Type I or II	EA
4	C	9140-00-286-5284	Fuel, Diesel, W-F-8--, (DF-A, DFF-1, DF-2)	GAL
5	C		Fuel, Jet, MIL-T-5624 (JP-4, JP-5)	GAL
6	C		Fuel Oil No. 1 or No. 2, Commercial	GAL
7	C, O	0150-00-985-7246	Grease, Soft MIL-G-23827	LB
8	O, F	8010-01-229-9561	Paint, Green 383 CARC MIL-C-53039 (81347)	RL
9	O, F	8010-01-193-0518	Primer, Paint Epoxy Kit MIL-P-53022	EA
10	O, F		Sealer, 3M, MIL-M-22473D, Grade AB	EA
11	F	3439-00-043-3623	Solder, SN60, 1 LB Roll	LB
12	C, O, F	6850-00-281-1985	Solvent, Dry Cleaning, 1 Qt Cans, Fed Spec P-D-680	QT
13	O, F	9905-00-537-8954	Tags, Marker, 50 EA, MIL-T-12755 (81349)	LB
14	O	5970-00-644-3167	Tape, Insulation, Electrical, 85 ft HH-I-510 (81348)	RO

**HEATER, WATER, LIQUID FUEL M-80 AND M-85
MANDATORY REPLACEMENT PARTS LIST**

INTRODUCTION**Scope**

This work package includes a list of all mandatory replacement parts referenced in the task initial setups and procedures. These are items that must be replaced during maintenance whether they have failed or not. This includes items based on usage intervals such as miles, time, rounds fired, etc.

MANDATORY REPLACEMENT PARTS LIST**Table 1. Mandatory Replacement Parts List**

ITEM NO.	PART NUMBER/ CAGEC	NSN	NOMENCLATURE	QTY
1	6-1-6242/81337	5330-00-467-3553	GASKET, SPARKPLUG	
2	32845-31/15472	5330-00-360-5303	GASKET	
3	110441/1Y370	5330-00-375-1690	GASKET, COVER	
4	6-1-6223/81337	5330-01-373-9759	GASKET, SMOKE BOX COVER	
5	113331/1Y370	5330-00-718-6547	GASKET, PORT HOUSING	
6	6-1-6260/81337	5330-01-374-3662	GASKET, BURNER HEAD	
7	100901/1Y370	5330-00-527-7560	GASKET	
8	100371/1Y370	5330-00-472-6189	GASKET, END CAP	
9	6-1-6252-2/81337	6110-01-468-9932	GASKET	
10	6-1-6244/81337	5330-01-374-1501	GASKET, PEEP SIGHT	
11	6-1-6235/90958	5330-01-373-9758	GASKET, BLOWER	
12	100319/1Y370	5330-00-374-6104	PACKING, PREFORMED	
13	125122/1Y370	5331-00-218-0390	PACKING, PREFORMED	
14	125132/1Y370	5330-00-953-4407	PACKING, PREFORMED	
15	115462/1Y370	5330-00-482-7051	SEAL, STATIONARY FACE	
16	129792/1Y370	5330-00-391-3939	SEAL	
17	MS35333-39/96906	5310-00-576-5752	WASHER, LOCK	
18	MS35333-40/96906	5310-00-550-1130	WASHERS, LOCK INTERNAL TOOTH 0.250	
19	MS35333-42/96906	5310-00-595-7237	WASHER, LOCK INTERNAL TOOTH 0.250	
20	MS15795-910/96906	5310-00-045-5210	WASHER, FLAT 0.281 ID x 0.625 OD x 0.065 THK	
21	129521/1Y370		WASHER	
22	MS27183-9/96906	5310-00-823-8804	WASHER, FLAT	
23	MS 27183-10/90906	5310-00-809-4058	WASHER, FLAT 0.281	

TM 10-4520-259-13&P
HEATER, WATER, LIQUID FUEL, M-80 & M-85
ALPHABETICAL INDEX

Subject	WP No.
A	
Abbreviations/Acronyms, List of	0001 00-3
Additional Authorization List	0056 00-1
Adjustments, Initial	0005 00-6
Air Shutter Assembly, Direct Support	0033 00-1
Assembly and Installation	0005 00-2
Assembly and Preparation For Use	0005 00-1
B	
Basic Issue Items (BII) List	0055 00-1
Blower and Fuel Pump Motor, Direct Support	0031 00-1
Blower Assembly - Repair Parts and Special Tools List – Group 05	0045 00-2
Blower Assembly, Direct Support	0030 00-1
Blower Assembly, Operator Maintenance	0015 00-1
Burner Head Assembly - Repair Parts and Special Tools List – Group 02	0041 00-1
Burner Head Assembly, Unit Maintenance	0019 00-1
C	
Capabilities and Features, Equipment Characteristics	0002 00-1
Cautions	0001 00-3
Characteristics, Equipment	0002 00-1
Common Tools and Equipment	0002 00-5
Components Of End Item (COEI) List and Basic Issue Items (BII) List	0055 00-1
Control Box Assembly - Repair Parts and Special Tools List – Group 08	0050 00-2
Control Box Assembly, Direct Support	0035 00-1
Controls and Indicators	0004 00-1
Corrosion Prevention And Control (CPC)	0001 00-2
CPC (Corrosion Prevention And Control)	0001 00-2
Cross-Reference List, Nomenclature	0001 00-2
D	
Destruction of Army Materiel to Prevent Enemy Use	0001 00-2
Difference Between Models	0002 00-5
Direct Support Troubleshooting Procedures	0028 00-1
Direct Support, Air Shutter Assembly	0033 00-1
Direct Support, Blower And Fuel Pump Motor	0031 00-1
Direct Support, Blower Assembly	0030 00-1
Direct Support, Control Box Assembly	0035 00-1
Direct Support, Electrical Components	0029 00-1
Direct Support, Fuel Pump Assembly	0032 00-1
Direct Support, Water Vessel and Skid Assembly	0034 00-1
Drum Fill Adapter Assembly, Unit Maintenance	0026 00-1
Drum Fill Adapter Assembly - Repair Parts and Special Tools List – Group 09	0052 00-2

Subject	WP No.
E	
EIRS (Equipment Improvement Recommendations), Reporting	0001 00-2
Electrical Components - Repair Parts and Special Tools List – Group 0401	0044 00-2
Electrical Components, Direct Support	0029 00-1
Equipment Characteristics, Capabilities and Features	0002 00-1
Equipment Data	0002 00-6
Expendable and Durable Items List	0057 00-1
F	
Features, Equipment	0002 00-1
Flame Safeguard, UV and IR - Repair Parts and Special Tools List – Group 07	0051 00-2
Fuel Filter Assembly - Repair Parts and Special Tools List – Group 0502	0046 00-2
Fuel Filter Assembly, Unit Maintenance	0022 00-1
Fuel Pump - Repair Parts and Special Tools List – Group 0503	0047 00-2
Fuel Pump Assembly, Direct Support	0032 00-1
Fuel Pump Assembly, Unit Maintenance	0023 00-1
Fuel Supply Control Components - Repair Parts and Special Tools List – Group 01	0040 00-2
Fuel Supply Control Components, Operator Maintenance	0012 00-1
Fuel Supply Control Components, Unit Maintenance	0018 00-1
G	
General Information	0001 00-1
H	
How To Use This Manual	iv
I	
Ignition Cable Assemblies, Operator Maintenance	0014 00-1
Ignition Transformer - Repair Parts and Special Tools List – Group 04	0043 00-2
Ignition Transformer and Cable Assemblies, Unit Maintenance	0021 00-1
Initial Adjustments	0005 00-6
Installation	0005 00-2
Introduction to Repair Parts and Special Tools List	0039 00-1
IR and UV Flame Safeguard - Repair Parts and Special Tools List – Group 07	0051 00-2
IR and UV Scanner and Flame Control Safeguard Assembly, Direct Support	0027 00-1
L	
Leakage Criteria	0009 00-2
List of Abbreviations/Acronyms	0001 00-3
List of Effective Pages	A
Location and Description of Major Components	0002 00-2
Lubrication Requirements	0010 00-1
M	
MAC	0038 00-1
Maintenance Allocation Chart, Introduction	0037 00-1

Subject	WP No.
M - continued	
Maintenance Forms Records and Reports	0001 00-2
Malfunction Symptom Index, Operator	0007 00-1
Malfunction Symptom Index, Unit	0017 00-1
Malfunction Symptom Index, Direct Support	0028 00-1
Mandatory Replacement Parts List	0060 00-1
Manifold Assembly, Upper and Lower , Unit Maintenance	0025 00-1
Manifold, Upper and Lower - Repair Parts and Special Tools List – Group 0601	0049 00-2
N	
National Stock Number Index	0055 00-1
Nomenclature Cross-Reference List	0001 00-2
Notes	0001 00-3
O	
Operating Procedures	0005 00-8
Operation Under Unusual Conditions	0006 00-1
Operator Maintenance, Blower Assembly	0015 00-1
Operator Maintenance, Fuel Supply Control Components	0012 00-1
Operator Maintenance, Ignition Cable Assemblies	0014 00-1
Operator Maintenance, Smokestack and Guard Assemblies/M-85, Exhaust Duct	0013 00-1
Operator Maintenance, Water Vessel and Skid Assembly	0016 00-1
Operator Troubleshooting Procedures	0007 00-1
P	
Part Number Index	0056 00-1
PMCS (Preventive Maintenance Checks and Services)	0011 00-1
Preparation For Movement	0005 00-12
Preparation For Use	0005 00-1
Preventive Maintenance Checks and Services (PMCS)	0011 00-1
R	
References	0002 00-7
References	0036 00-1
References (Pamphlets)	0036 00-1
References (Field Manual)	0036 00-1
References (Forms)	0036 00-1
References (TB)	0036 00-1
References (TM)	0036 00-1
Repair Parts and Special Tools List – Group 01 Fuel Supply Control Comp	0040 00-2
Repair Parts and Special Tools List – Group 02 Burner Head Assembly	0041 00-1
Repair Parts and Special Tools List – Group 03 Smokestack and Guard	0042 00-2
Repair Parts and Special Tools List – Group 04 Ignition Transformer	0043 00-2
Repair Parts and Special Tools List – Group 0401 Electrical Components	0044 00-2

Subject	WP No.
R - continued	
Repair Parts and Special Tools List – Group 05 Blower Assembly	0045 00-2
Repair Parts and Special Tools List – Group 0502 Fuel Filter Assembly	0046 00-2
Repair Parts and Special Tools List – Group 0503 Fuel Pump	0047 00-2
Repair Parts and Special Tools List – Group 06 Water Vessel And Skid Assembly	0048 00-2
Repair Parts and Special Tools List – Group 0601 Upper And Lower Manifold	0049 00-2
Repair Parts and Special Tools List – Group 07 UV And IR Flame Safeguard	0050 00-2
Repair Parts and Special Tools List – Group 08 Control Box Assembly	0051 00-2
Repair Parts and Special Tools List – Group 09 Drumfill Adapter	0052 00-2
Repair Parts and Special Tools List, Introduction	0039 00-1
Reporting Equipment Improvement Recommendations (EIR)	0001 00-2
S	
Safety, Care and Handling, Warnings, Cautions and Notes	0001 00-3
Scanner And Flame Control Safeguard Assembly, UV and IR , Direct Support	0027 00-1
Service Upon Receipt	0008 00-1
Shutdown Procedures	0005 00-10
Siting Requirements	0005 00-1
Smokestack and Guard Assembly, M-80/Exhaust Duct M-85, Unit Maintenance	0020 00-1
Smokestack and Guard Assembly, Repair Parts and Special Tools List – Group 03	0042 00-2
Smokestack and Guard Assemblies, Exhaust Duct, Operator Maintenance	0013 00-1
T	
Theory of Operation	0003 00-1
Troubleshooting Procedures, Direct Support	0028 00-1
Troubleshooting Procedures, Operator Maintenance	0007 00-1
Troubleshooting Procedures, Unit Maintenance	0017 00-1
U	
Unit Maintenance, Burner Head Assembly	0019 00-1
Unit Maintenance, Drum Fill Adapter Assembly, Type II	0026 00-1
Unit Maintenance, Fuel Filter Assembly	0022 00-1
Unit Maintenance, Fuel Pump Assembly	0023 00-1
Unit Maintenance, Fuel Supply Control Components	0018 00-1
Unit Maintenance, Ignition Transformer and Cable Assemblies	0021 00-1
Unit Maintenance, Smokestack and Guard Assembly, M-80/Exhaust Duct M-85	0020 00-1
Unit Maintenance, UV and IR Scanner and Flame Control Safeguard Assembly	0027 00-1
Unit Maintenance, Upper and Lower Manifold Assembly	0025 00-1
Unit Maintenance, Water Vessel and Skid Assembly	0024 00-1
Unit Troubleshooting Procedures	0017 00-1
Upper and Lower Manifold - Repair Parts and Special Tools List – Group 0601	0049 00-2
Upper and Lower Manifold Assembly, Unit Maintenance	0025 00-1
UV and IR Flame Safeguard - Repair Parts and Special Tools List – Group 07	0051 00-2

Subject	WP No.
U – continued	
UV and IR Scanner and Flame Control Safeguard Assembly, Unit Maintenance	0027 00-1
W	
Warning Summary	a
Warnings	0001 00-3
Warranty Information	0001 00-2
Water Vessel and Skid Assembly - Repair Parts and Special Tools List – Group 06	0048 00-2
Water Vessel and Skid Assembly, Direct Support	0034 00-1
Water Vessel and Skid Assembly, Operator Maintenance	0016 00-1
Water Vessel and Skid Assembly, Unit Maintenance	0024 00-1

By Order of the Secretary of the Army:

PETER J. SCHOOMAKER
General, United States Army
Chief of Staff

Official:

SANDRA R. RILEY
*Administrative Assistant to the
Secretary of the Army*
0514004

Distribution: To be distributed in accordance with initial distribution number (IDN) 256159 requirements for TM 10-4520-259-13&P.

These are the instructions for sending an electronic 2028

The following format must be used if submitting an electronic 2028. The subject line must be exactly the same and all fields must be included; however only the following fields are mandatory: 1, 3, 4, 5, 6, 7, 8, 9, 10, 13, 15, 16, 17, and 27.

From: "Whomever" <whomever@avma27.army.mil>
To: amssbriml@natick.army.mil

Subject: DA Form 2028

1. From: Joe Smith
2. Unit: home
3. Address: 4300 Park
4. City: Hometown
5. St: MO
6. Zip: 77777
7. Date Sent: 19-OCT-93
8. Pub no: 55-2840-229-23
9. Pub Title: TM
10. Publication Date: 04-JUL-85
11. Change Number: 7
12. Submitter Rank: MSG
13. Submitter FName: Joe
14. Submitter MName: T
15. Submitter LName: Smith
16. Submitter Phone: 123-123-1234
17. Problem: 1
18. Page: 2
19. Paragraph: 3
20. Line: 4
21. NSN: 5
22. Reference: 6
23. Figure: 7
24. Table: 8
25. Item: 9
26. Total: 123
27. Text:

This is the text for the problem below line 27.

RECOMMENDED CHANGES TO PUBLICATIONS AND BLANK FORMS For use of this form, see AR 25-30; the proponent agency is ODISC4.						Use Part II (reverse) for Repair Parts and Special Tool Lists (RPSTL) and Supply Catalogs/Supply Manuals (SC/SM).	DATE 21 October 2003
TO: (Forward to proponent of publication or form) (Include ZIP Code) US ARMY TANK AUTOMOTIVE AND ARMAMENT COMMAND ATTN: AMSTA-LC-CECT 15 KANSAS ST NATICK, MA 01760-5052						FROM: (Activity and location) (Include ZIP Code) PFC JANE DOE Co A 3 RD Engineer Br. Ft Leonard Wood, MO 63108	
PART I – ALL PUBLICATIONS (EXCEPT RPSTL AND SC/SM) AND BLANK FORMS							
PUBLICATION/FORM NUMBER TM 10-1670-296-23&P				DATE 30 October 2002	TITLE Unit Manual for Ancillary Equipment for Low Velocity Air Drop Systems		
ITEM NO.	PAGE NO.	PARA-GRAPH	LINE NO. *	FIGURE NO.	TABLE NO.	RECOMMENDED CHANGES AND REASON (Provide exact wording of recommended changes, if possible).	
	0036 00-2				1	In Table 1, Sewing Machine Code Symbols, the second sewing machine code symbol should be MDZZ not MD22 Change the manual to show Sewing Machine, Industrial: Zig-Zag; 308 stitch; medium-duty; NSN 3530-01-181-1421 as a MDZZ code symbol.	
*Reference to line numbers within the paragraph or subparagraph.							
TYPED NAME, GRADE OR TITLE Jane Doe, PFC				TELEPHONE EXCHANGE/AUTOVON, PLUS EXTENSION (508) 233-4141 DSN 256-4141		SIGNATURE Jane Doe Jane Doe	

TO: (Forward direct to addressee listed in publication) US ARMY TANK AUTOMOTIVE AND ARMAMENT COMMAND ATTN: AMSTA-LC-CECT 15 KANSAS ST NATICK, MA 01760-5052	FROM: (Activity and location) (Include ZIP Code) PFC JANE DOE Co A 3 RD Engineer Br. Ft Leonard Wood, MO 63108	DATE 21 October 2003
---	---	--------------------------------

PART II – REPAIR PARTS AND SPECIAL TOOL LISTS AND SUPPLY CATALOGS/SUPPLY MANUALS

PUBLICATION NUMBER TM 10-1670-296-23&P	DATE 30 October 2002	TITLE Unit Manual for Ancillary Equipment for Low Velocity Air Drop Systems
---	-------------------------	---

PAGE NO.	COLM NO.	LINE NO.	NATIONAL STOCK NUMBER	REFERENCE NO.	FIGURE NO.	ITEM NO.	TOTAL NO. OF MAJOR ITEMS SUPPORTED	RECOMMENDED ACTION
0066 00-1					4			Callout 16 in figure 4 is pointed to a <u>D-Ring</u> . In the Repair Part List key for Figure 4, item 16 is called a <u>Snap Hook</u> . Please correct one or the other.

PART III – REMARKS (Any general remarks or recommendations, or suggestions for improvement of publications and blank forms. Additional blank sheets may be used if more space is needed.)

--

TYPED NAME, GRADE OR TITLE	TELEPHONE EXCHANGE/AUTOVON, PLUS EXTENSION	SIGNATURE
----------------------------	--	-----------

RECOMMENDED CHANGES TO PUBLICATIONS AND BLANK FORMS						Use Part II (reverse) for Repair Parts and Special Tool Lists (RPSTL) and Supply Catalogs/Supply Manuals (SC/SM).	DATE
For use of this form, see AR 25-30; the proponent agency is ODISC4.							
TO: (Forward to proponent of publication or form) (Include ZIP Code) Commander, U.S. Army Tank-automotive & Armament Command ATTN: AMSTA LC-CECT, Kansas Street Natick, MA 01760-5052						FROM: (Activity and location) (Include ZIP Code)	
PART I – ALL PUBLICATIONS (EXCEPT RPSTL AND SC/SM) AND BLANK FORMS							
PUBLICATION/FORM NUMBER				DATE	TITLE		
TM 10-4520-259-13&P				30 JUNE 2005	Operator's, Unit and Direct Support Maintenance Manual (Including Repair Parts and Special Tools List) for the M-80/M-85 Liquid Fuel Water Heater.		
ITEM NO.	PAGE NO.	PARA-GRAPH	LINE NO. *	FIGURE NO.	TABLE NO.	RECOMMENDED CHANGES AND REASON (Provide exact wording of recommended changes, if possible).	
*Reference to line numbers within the paragraph or subparagraph.							
TYPED NAME, GRADE OR TITLE				TELEPHONE EXCHANGE/AUTOVON, PLUS EXTENSION		SIGNATURE	

TO: <i>(Forward direct to addressee listed in publication)</i>	FROM: <i>(Activity and location) (Include ZIP Code)</i>	DATE
---	--	-------------

PART II – REPAIR PARTS AND SPECIAL TOOL LISTS AND SUPPLY CATALOGS/SUPPLY MANUALS

PUBLICATION NUMBER TM 10-4520-259-13&P	DATE 30 JUNE 2005	TITLE Operator's, Unit and Direct Support Maintenance Manual (Including Repair Parts and Special Tools List) for the M-80/M-85 Liquid Fuel Water Heater.
---	--------------------------	--

PAGE NO.	COLM NO.	LINE NO.	NATIONAL STOCK NUMBER	REFERENCE NO.	FIGURE NO.	ITEM NO.	TOTAL NO. OF MAJOR ITEMS SUPPORTED	RECOMMENDED ACTION

PART III – REMARKS *(Any general remarks or recommendations, or suggestions for improvement of publications and blank forms. Additional blank sheets may be used if more space is needed.)*

TYPED NAME, GRADE OR TITLE	TELEPHONE EXCHANGE/AUTOVON, PLUS EXTENSION	SIGNATURE
----------------------------	--	-----------

RECOMMENDED CHANGES TO PUBLICATIONS AND BLANK FORMS						Use Part II (reverse) for Repair Parts and Special Tool Lists (RPSTL) and Supply Catalogs/Supply Manuals (SC/SM).	DATE
For use of this form, see AR 25-30; the proponent agency is ODISC4.							
TO: (Forward to proponent of publication or form) (Include ZIP Code) Commander, U.S. Army Tank-automotive & Armament Command ATTN: AMSTA LC-CECT, Kansas Street Natick, MA 01760-5052						FROM: (Activity and location) (Include ZIP Code)	
PART I – ALL PUBLICATIONS (EXCEPT RPSTL AND SC/SM) AND BLANK FORMS							
PUBLICATION/FORM NUMBER					DATE	TITLE	
TM 10-4520-259-13&P					30 JUNE 2005	Operator's, Unit and Direct Support Maintenance Manual (Including Repair Parts and Special Tools List) for the M-80/M-85 Liquid Fuel Water Heater.	
ITEM NO.	PAGE NO.	PARA-GRAPH	LINE NO.*	FIGURE NO.	TABLE NO.	RECOMMENDED CHANGES AND REASON (Provide exact wording of recommended changes, if possible).	
<i>*Reference to line numbers within the paragraph or subparagraph.</i>							
TYPED NAME, GRADE OR TITLE					TELEPHONE EXCHANGE/AUTOVON, PLUS EXTENSION	SIGNATURE	

TO: (Forward direct to addressee listed in publication)	FROM: (Activity and location) (Include ZIP Code)	DATE
--	---	-------------

PART II – REPAIR PARTS AND SPECIAL TOOL LISTS AND SUPPLY CATALOGS/SUPPLY MANUALS

PUBLICATION NUMBER TM 10-4520-259-13&P	DATE 30 JUNE 2005	TITLE Operator's, Unit and Direct Support Maintenance Manual (Including Repair Parts and Special Tools List) for the M-80/M-85 Liquid Fuel Water Heater.
--	-----------------------------	--

PAGE NO.	COLM NO.	LINE NO.	NATIONAL STOCK NUMBER	REFERENCE NO.	FIGURE NO.	ITEM NO.	TOTAL NO. OF MAJOR ITEMS SUPPORTED	RECOMMENDED ACTION

PART III – REMARKS (Any general remarks or recommendations, or suggestions for improvement of publications and blank forms. Additional blank sheets may be used if more space is needed.)

--

TYPED NAME, GRADE OR TITLE	TELEPHONE EXCHANGE/AUTOVON, PLUS EXTENSION	SIGNATURE
----------------------------	--	-----------

RECOMMENDED CHANGES TO PUBLICATIONS AND BLANK FORMS For use of this form, see AR 25-30; the proponent agency is ODISC4.						Use Part II (reverse) for Repair Parts and Special Tool Lists (RPSTL) and Supply Catalogs/Supply Manuals (SC/SM).	DATE
TO: (Forward to proponent of publication or form) (Include ZIP Code) Commander, U.S. Army Tank-automotive & Armament Command ATTN: AMSTA LC-CECT, Kansas Street Natick, MA 01760-5052						FROM: (Activity and location) (Include ZIP Code)	
PART I – ALL PUBLICATIONS (EXCEPT RPSTL AND SC/SM) AND BLANK FORMS							
PUBLICATION/FORM NUMBER TM 10-4520-259-13&P						DATE 30 JUNE 2005	TITLE Operator's, Unit and Direct Support Maintenance Manual (Including Repair Parts and Special Tools List) for the M-80/M-85 Liquid Fuel Water Heater.
ITEM NO.	PAGE NO.	PARA-GRAPH	LINE NO. *	FIGURE NO.	TABLE NO.	RECOMMENDED CHANGES AND REASON <i>(Provide exact wording of recommended changes, if possible).</i>	
<i>*Reference to line numbers within the paragraph or subparagraph.</i>							
TYPED NAME, GRADE OR TITLE					TELEPHONE EXCHANGE/AUTOVON, PLUS EXTENSION		SIGNATURE

TO: <i>(Forward direct to addressee listed in publication)</i>	FROM: <i>(Activity and location) (Include ZIP Code)</i>	DATE
---	--	-------------

PART II – REPAIR PARTS AND SPECIAL TOOL LISTS AND SUPPLY CATALOGS/SUPPLY MANUALS

PUBLICATION NUMBER TM 10-4520-259-13&P	DATE 30 JUNE 2005	TITLE Operator's, Unit and Direct Support Maintenance Manual (Including Repair Parts and Special Tools List) for the M-80/M-85 Liquid Fuel Water Heater.
--	-----------------------------	--

PAGE NO.	COLM NO.	LINE NO.	NATIONAL STOCK NUMBER	REFERENCE NO.	FIGURE NO.	ITEM NO.	TOTAL NO. OF MAJOR ITEMS SUPPORTED	RECOMMENDED ACTION

PART III – REMARKS *(Any general remarks or recommendations, or suggestions for improvement of publications and blank forms. Additional blank sheets may be used if more space is needed.)*

TYPED NAME, GRADE OR TITLE	TELEPHONE EXCHANGE/AUTOVON, PLUS EXTENSION	SIGNATURE

The Metric System and Equivalents

Linear Measure

1 centimeter = 10 millimeters = .39 inch
 1 decimeter = 10 centimeters = 3.94 inches
 1 meter = 10 decimeters = 39.37 inches
 1 dekameter = 10 meters = 32.8 feet
 1 hectometer = 10 dekameters = 328.08 feet
 1 kilometer = 10 hectometers = 3,280.8 feet

Weights

1 centigram = 10 milligrams = .15 grain
 1 decigram = 10 centigrams = 1.54 grains
 1 gram = 10 decigrams = .035 ounce
 1 dekagram = 10 grams = .35 ounce
 1 hectogram = 10 dekagrams = 3.52 ounces
 1 kilogram = 10 hectograms = 2.2 pounds
 1 quintal = 100 kilograms = 220.46 pounds
 1 metric ton = 10 quintals = 1.1 short tons

Liquid Measure

1 centiliter = 10 milliliters = .34 fl. ounce
 1 deciliter = 10 centiliters = 3.38 fl. ounces
 1 liter = 10 deciliters = 33.81 fl. ounces
 1 dekaliter = 10 liters = 2.64 gallons
 1 hectoliter = 10 dekaliters = 26.42 gallons
 1 kiloliter = 10 hectoliters = 264.18 gallons

Square Measure

1 sq. centimeter = 100 sq. millimeters = .155 sq. inch
 1 sq. decimeter = 100 sq. centimeters = 15.5 sq. inches
 1 sq. meter (centare) = 100 sq. decimeters = 10.76 sq. feet
 1 sq. dekameter (are) = 100 sq. meters = 1,076.4 sq. feet
 1 sq. hectometer (hectare) = 100 sq. dekameters = 2.47 acres
 1 sq. kilometer = 100 sq. hectometers = .386 sq. mile

Cubic Measure

1 cu. centimeter = 1000 cu. millimeters = .06 cu. inch
 1 cu. decimeter = 1000 cu. centimeters = 61.02 cu. inches
 1 cu. meter = 1000 cu. decimeters = 35.31 feet

Approximate Conversion Factors

<i>To change</i>	<i>To</i>	<i>Multiply by</i>	<i>To change</i>	<i>To</i>	<i>Multiply by</i>
inches	centimeters	2.540	ounce-inches	newton-meters	.007062
feet	meters	.305	centimeters	inches	.394
yards	meters	.914	meters	feet	3.280
miles	kilometers	1.609	meters	yards	1.094
square inches	square centimeters	6.451	kilometers	miles	.621
square feet	square meters	.093	square centimeters	square inches	.155
square yards	square meters	.836	square meters	square feet	10.764
square miles	square kilometers	2.590	square meters	square yards	1.196
acres	square hectometers	.405	square kilometers	square miles	.386
cubic feet	cubic meters	.028	square hectometers	acres	2.471
cubic yards	cubic meters	.765	cubic meters	cubic feet	35.315
fluid ounces	milliliters	29.573	cubic meters	cubic yards	1.308
pints	liters	.473	milliliters	fluid ounces	.034
quarts	liters	.946	liters	pints	2.113
gallons	liters	3.785	liters	quarts	1.057
ounces	grams	28.349	liters	gallons	.264
pounds	kilograms	.454	grams	ounces	.035
short tons	metric tons	.907	kilograms	pounds	2.205
pound-feet	newton-meters	1.356	metric tons	short tons	1.102
pound-inches	newton-meters	.11296			

Temperature (Exact)

$\frac{5}{9}$ (after subtracting 32)

Fahrenheit temperature

Celsius temperature

$\frac{9}{5}$ (after adding 32)

